

Uncertain Discrete-Time Systems with Delayed State: Robust Stabilization with Performance Specification via LMI Formulations

Valter J. S. Leite¹, Michelle F. F. Castro², André F. Caldeira³, Márcio F. Miranda⁴ and Eduardo N. Gonçalves⁶
^{1,2,3}CEFET-MG / campus Divinópolis
⁴UFMG / COLTEC ⁵CEFET-MG / campus II
 Brazil

1. Introduction

This chapter is about techniques for robust stability analysis and robust stabilization of discrete-time systems with delay in the state vector. The relevance of this study is mainly due to the unavoidable presence of delays in dynamic systems. Even small time-delays can reduce the performance of systems and, in some cases, lead them to instability. Examples of such systems are robotics, networks, metal cutting, transmission lines, chemical and thermal processes among others as can be found in the books from Gu et al. (2003), Richard (2003), Niculescu (2001) and Kolmanovskii & Myshkis (1999).

Studies and techniques for dealing with such systems are not new. Since the beginning of control theory, researchers has been concerned with this issue, either in the input-output approach or in state-space approach. For the input-output approach, techniques such as Padé approximation and the Smith predictor are widely used, mainly for process control. The use of state space approach allows to treat both cases. For both approaches delays can be constant or time-varying. Besides, both the delay and the systems can be precisely known or affected by uncertainties.

In this chapter the class of uncertain discrete-time systems with state delay is studied. For these systems, the techniques for analysis and design could be delay dependent or delay independent, can lead with precisely known or uncertainty systems (in a polytopic or in a norm-bonded representation, for instance), and can consider constant or time-varying delays. For discrete-time systems with constant and known delay in the state it is always possible to study an augmented delay-free system Kapila & Haddad (1998), Leite & Miranda (2008a). However, this solution does not seem to be suitable to several cases such as time-varying delay or uncertain systems.

For these systems, most of the applied techniques for robust stability analysis an robust control design are based on Lyapunov-Krasovskii (L-K) approach, which can be used to obtain convex formulation problems in terms of linear matrix inequalities (LMIs).

In the literature it is possible to find approaches based on LMIs for stability analysis, most of them based on the quadratic stability (QS), i.e., with the matrices of the Lyapunov-Krasovskii function being constant and independent of the uncertain parameters.

In the context of QS, non-convex formulations of delay-independent type have been proposed, for example, in Shi et al. (2003) where the delay is considered time-invariant. In Fridman &

Shaked (2005a) and Fridman & Shaked (2005b), delay dependent conditions, convex to the analysis of stability and non-convex for the synthesis, are formulated using the approach of descriptor systems. These works consider systems with both polytopic uncertainties — see Fridman & Shaked (2005a) — and with norm-bounded uncertainties as done by Fridman & Shaked (2005b).

Some other different aspects of discrete-time systems with delayed state have been studied. Kandanvli & Kar (2009) present a proposal with LMI conditions for robust stability analysis of discrete time delayed systems with saturation. In the work of Xu & Yu (2009), bi-dimensional (2D) discrete-time systems with delayed state are investigated, and delay-independent conditions for norm-bounded uncertainties and constant delay are given by means of nonconvex formulations. In the paper from Ma et al. (2008), convex conditions have been proposed for discrete-time singular systems with time-invariant delay. Discrete-time switched systems with delayed state have been studied by Hetel et al. (2008) and Ibrir (2008). The former establishes the equivalence between the approach used here (Lyapunov-Krasovskii functions) and the one used, in general, for the stability of switched systems with time-varying delay. The latter gives nonconvex conditions for switched systems where each operation mode is subject to a norm-bounded uncertainty and constant delay.

The problem of robust filtering for discrete-time uncertain systems with delayed state is considered in some papers. Delayed state systems with norm-bounded uncertainties are studied by Yu & Gao (2001), Chen et al. (2004) and Xu et al. (2007) and with polytopic uncertainties by Du et al. (2007). The results of Gao et al. (2004) were improved by Liu et al. (2006), but the approach is based on QS and the design conditions are nonconvex depending directly on the Lyapunov-Krasovskii matrices.

The problem of output feedback has attracted attention for discrete-time systems with delay in the state and the works of Gao et al. (2004), He et al. (2008) and Liu et al. (2006) can be cited as examples of on going research. In special, He et al. (2008) present results for precisely known systems with time-varying delay including both static output feedback (SOF) and dynamic output feedback (DOF). However, the conditions are presented as an interactive method that relax some matrix inequalities.

The main objective of this chapter is to study the robust analysis and synthesis of discrete-time systems with state delay. This chapter is organized as follows. In Section 2 some notations and statements are presented, together the problems that are studied and solved in the next sections. In sections 3 and 4 solutions are presented for, respectively, robust stability analysis and robust design, based in a L-K function presented in section 2. In Section 5 some additional results are given by the application of the techniques developed in previous sections are presented, such as: extensions for switched systems, to treat actuator failure and to make design with pole location. In the last section it is presented the final comments.

2. Preliminaries and problem statement

In this chapter the uncertain discrete time system with time-varying delay in the state vector is given by

$$\Omega(\alpha) : \begin{cases} x_{k+1} = A(\alpha)x_k + A_d(\alpha)x_{k-d_k} + B(\alpha)u_k + B_w(\alpha)w_k, \\ z_k = C(\alpha)x_k + C_d(\alpha)x_{k-d_k} + D(\alpha)u_k + D_w(\alpha)w_k, \end{cases} \quad (1)$$

where k is the k -th sample-time, matrices $A(\alpha)$, $A_d(\alpha)$, $B(\alpha)$, $B_w(\alpha)$, $C(\alpha)$, $C_d(\alpha)$, $D(\alpha)$ and $D_w(\alpha)$ are time-invariant, uncertain and with adequate dimensions defined in function of the signals $x_k = x(k) \in \mathbb{R}^n$, the state vector at sample-time k , $u_k = u(k) \in \mathbb{R}^m$, representing the control vector with m control signals, $w_k = w(k) \in \mathbb{R}^\ell$, the exogenous input vector with ℓ input

signals, and $z_k = z(k) \in \mathbb{R}^p$, the output vector with p weight output signals. These matrices can be described by a polytope \mathcal{P} with known vertices

$$\mathcal{P} = \left\{ \Omega(\alpha) \in \mathbb{R}^{n+p \times 2n+m+\ell} : \Omega(\alpha) = \sum_{i=1}^N \alpha_i \Omega_i, \alpha \in Y \right\}, \tag{2}$$

where

$$Y = \left\{ \alpha : \sum_{i=1}^N \alpha_i = 1, \alpha_i \geq 0, i \in \mathcal{I}[1, N] \right\} \tag{3}$$

and

$$\Omega_i = \left[\begin{array}{cc|cc} A_i & A_{di} & B_i & B_{wi} \\ \hline C_i & C_{di} & D_i & D_{wi} \end{array} \right], i \in \mathcal{I}[1, N]. \tag{4}$$

The delay, denoted by d_k , is supposed to be time-varying and given by:

$$d_k \in \mathcal{I}[\underline{d}, \bar{d}], (\underline{d}, \bar{d}) \in \mathbb{N}_*^2 \tag{5}$$

with \underline{d}, \bar{d} representing the minimum and maximum values of d_k , respectively. Thus, any system $\Omega(\alpha) \in \mathcal{P}$ can be written as a convex combination of the N vertices $\Omega_i, i \in \mathcal{I}[1, N]$, of \mathcal{P} .

The following control law is considered in this chapter:

$$u_k = Kx_k + K_d x_{k-d_k} \tag{6}$$

with $[K|K_d] \in \mathbb{R}^{m \times 2n}$. By replacing (6) in (1)-(4), the resulting uncertain closed-loop system is given by

$$\tilde{\Omega}(\alpha) : \begin{cases} x_{k+1} = \tilde{A}(\alpha)x_k + \tilde{A}_d(\alpha)x_{k-d_k} + B_w(\alpha)w_k \\ z_k = \tilde{C}(\alpha)x_k + \tilde{C}_d(\alpha)x_{k-d_k} + D_w(\alpha)w_k \end{cases} \tag{7}$$

with $\tilde{\Omega}(\alpha) \in \tilde{\mathcal{P}}$,

$$\tilde{\mathcal{P}} = \left\{ \tilde{\Omega}(\alpha) \in \mathbb{R}^{n+p \times 2n+\ell} : \tilde{\Omega}(\alpha) = \sum_{i=1}^N \alpha_i \tilde{\Omega}_i, \alpha \in Y \right\} \tag{8}$$

where

$$\tilde{\Omega}_i = \left[\begin{array}{cc|cc} \tilde{A}_i & \tilde{A}_{di} & B_{wi} & \\ \hline \tilde{C}_i & \tilde{C}_{di} & D_{wi} & \end{array} \right], i \in \mathcal{I}[1, N]. \tag{9}$$

and matrices $\tilde{A}_i, \tilde{A}_{di}, \tilde{C}_i$ e \tilde{C}_{di} are defined by

$$\tilde{A}_i = A_i + B_i K, \quad \tilde{A}_{di} = A_{di} + B_i K_d, \tag{10}$$

$$\tilde{C}_i = C_i + D_i K, \quad \tilde{C}_{di} = C_{di} + D_i K_d \tag{11}$$

Note that, control law (6) requires that both x_k and x_{k-d_k} are available at each sample-time. Eventually, this can be achieved in physical systems by employing, for instance, a time-stamped in the measurements or in the estimated states Srinivasagupta et al. (2004). In case of d_k is not known, it is sufficient to assume $K_d = 0$.

2.1 Stability conditions

Since the stability of system $\tilde{\Omega}(\alpha)$ given in (7) plays a central role in this work, it is addressed in the sequence. Note that, without loss of generality, it is possible to consider the stability of the system (7) with $w_k = \mathbf{0}, \forall k \in \mathbb{N}$.

Consider the sequence composed by $\bar{d} + 1$ null vectors

$$\hat{\phi}_{\bar{d}} = \underbrace{\{\mathbf{0}, \dots, \mathbf{0}\}}_{(\bar{d}+1) \text{ terms}}$$

In this chapter null initial conditions are always assumed, that is,

$$x_k = \phi_{0,k} = \hat{\phi}_{\bar{d}}, \quad k \in \mathcal{I}[-\bar{d}, 0] \tag{12}$$

If $\phi_{t,k} = \hat{\phi}_{\bar{d}}$, then an equilibrium solution for system (7) with $w_k = \mathbf{0}, \forall k \in \mathbb{N}$, is achieved because $x_{k+1} = x_k = \mathbf{0}, \forall k > t$ and $\alpha \in \tilde{\Omega}$.

Definition 1 (Uniform asymptotic stability). *For a given $\alpha \in Y$, the trivial solution of (7) with $w_k = \mathbf{0}, \forall k \in \mathbb{N}$ is said uniformly asymptotically stable if for any $\kappa \in \mathbb{R}_+$ such that for all initial conditions $x_k \in \phi_{0,k}^{\bar{d}} \in \Phi_{\bar{d}}^{\kappa}, k \in \mathcal{I}[-\bar{d}, 0]$, it is verified*

$$\lim_{t \rightarrow \infty} \phi_{t,j,k}^{\bar{d}} = \mathbf{0}, \quad \forall j \in \mathcal{I}[1, \bar{d} + 1]$$

This allows the following definition:

Definition 2 (Robust stability). *System (7) subject to (3), (5) and (8) is said robustly stable if its respective trivial solution is uniformly asymptotically stable $\forall \alpha \in Y$.*

The main objective in this work is to formulate convex optimization problems, expressed as LMIs, allowing an efficient numerical solution to a set of stability and performance problems.

2.2 Problems

Two sets of problems are investigated in this chapter. The first set concerns stability issues related to uncertain discrete time with time varying delay in the state vector as presented in the sequence.

Problem 1 (Robust stability analysis). *Determine if system (7) subject to (3), (5) and (8) is robustly stable.*

Problem 2 (Robust control design). *Determine a pair of static feedback gains, K and K_d , such that (1)-(5) controlled by (6) is robustly stable.*

The other set of problems is related to the performance of the class of systems considered in this chapter. In this proposal, the \mathcal{H}_∞ index is used to quantify the performance of the system as stated in the following problems:

Problem 3 (\mathcal{H}_∞ guaranteed cost). *Given the uncertain system $\tilde{\Omega}(\alpha) \in \tilde{\mathcal{P}}$, determine an estimation for $\gamma > 0$ such that for all $w_k \in \ell_2$ there exist $z_k \in \ell_2$ satisfying*

$$\|z_k\|_2 < \gamma \|w_k\|_2 \tag{13}$$

for all $\alpha \in Y$. In this case, γ is called an \mathcal{H}_∞ guaranteed cost for (7).

Problem 4 (Robust \mathcal{H}_∞ control design). *Given the uncertain system $\Omega(\alpha) \in \tilde{\mathcal{P}}$, (1), and a scalar $\gamma > 0$, determine robust state feedback gains K and K_d , such that the uncertain closed-loop system $\tilde{\Omega}(\alpha) \in \tilde{\mathcal{P}}$, (7), is robustly stable and, additionally, satisfies (13) for all w_k and z_k belonging to ℓ_2 .*

It is worth to say that, in cases where time-delay depends on a physical parameter (such as velocity of a transport belt, the position of a steam valve, etc.) it may be possible to determine the delay value at each sample-time. As a special case, consider the regenerative chatter in metal cutting. In this process a cylindrical workpiece has an angular velocity while a machine tool (lathe) translates along the axis of this workpiece. For details, see (Gu et al., 2003, pp. 2). In this case the delay depends on the angular velocity and can be recovered at each sample-time k . However, the study of a physical application is not the objective in this chapter.

The following parameter dependent L-K function is used in this paper to investigate problems 1-4:

$$V(\alpha, k) = \sum_{v=1}^3 V_v(\alpha, k) > 0 \tag{14}$$

with

$$V_1(\alpha, k) = x_k' P(\alpha) x_k, \tag{15}$$

$$V_2(\alpha, k) = \sum_{j=k-d_k}^{k-1} x_j' Q(\alpha) x_j, \tag{16}$$

$$V_3(\alpha, k) = \sum_{\ell=2-\bar{d}}^{1-\bar{d}} \sum_{j=k+\ell-1}^{k-1} x_j' Q(\alpha) x_j, \tag{17}$$

The dependency of matrices $P(\alpha)$ and $Q(\alpha)$ on the uncertain parameter α is a key issue on reducing the conservatism of the resulting conditions. Here, a linear relation on α is assumed. Thus, consider the following structure for these matrices:

$$P(\alpha) = \sum_{i=1}^N \alpha_i P_i; \quad Q(\alpha) = \sum_{i=1}^N \alpha_i Q_i \tag{18}$$

with $\alpha \in Y$. Note that, more general structures such as $P(\alpha)$ and $Q(\alpha)$ depending homogeneously on α — see Oliveira & Peres (2005) — may result in less conservative conditions, but at the expense of a higher numerical complexity of the resulting conditions.

To be a L-K function, the candidate (14) must be positive definite and satisfy

$$\Delta V(\alpha, k) = V(\alpha, k+1) - V(\alpha, k) < 0 \tag{19}$$

for all $\begin{bmatrix} x_k^T & x_{k-d_k}^T \end{bmatrix}^T \neq \mathbf{0}$ and $\alpha \in Y$.

The following result is used in this work to obtain less conservative results and to decouple the matrices of the system from the L-K matrices $P(\alpha)$ and $Q(\alpha)$.

Lemma 1 (Finsler's Lemma). *Let $\varphi \in \mathbb{R}^n$, $\mathcal{M}(\alpha) = \mathcal{M}(\alpha)^T \in \mathbb{R}^{n \times n}$ and $\mathcal{G}(\alpha) \in \mathbb{R}^{m \times n}$ such that $\text{rank}(\mathcal{G}(\alpha)) < n$. Then, the following statements are equivalents:*

- i) $\varphi^T \mathcal{M}(\alpha) \varphi < \mathbf{0}$, $\forall \varphi : \mathcal{G}(\alpha) \varphi = \mathbf{0}$, $\varphi \neq \mathbf{0}$
- ii) $\mathcal{G}(\alpha)^{\perp T} \mathcal{M}(\alpha) \mathcal{G}(\alpha)^{\perp} < \mathbf{0}$,

- iii) $\exists \mu(\alpha) \in \mathbb{R}_+ : \mathcal{M}(\alpha) - \mu(\alpha)\mathcal{G}(\alpha)^T\mathcal{G}(\alpha) < \mathbf{0}$
- iv) $\exists \mathcal{X}(\alpha) \in \mathbb{R}^{n \times m} : \mathcal{M}(\alpha) + \mathcal{X}(\alpha)\mathcal{G}(\alpha) + \mathcal{G}(\alpha)^T\mathcal{X}(\alpha)^T < \mathbf{0}$

In the case of parameter independent matrices, the proof of this theorem can be found in de Oliveira & Skelton (2001). The proof for the case depending on α follows similar steps.

3. Robust stability analysis and \mathcal{H}_∞ guaranteed cost

In this section it is presented the conditions for stability analysis and calculation of \mathcal{H}_∞ guaranteed cost for system (7). The objective here is to present sufficient convex conditions for solving problems 1 and 3.

3.1 Robust stability analysis

Theorem 1. *If there exist symmetric matrices $\mathbf{0} < P_i \in \mathbb{R}^{n \times n}$, $\mathbf{0} < Q_i \in \mathbb{R}^{n \times n}$, a matrix $\mathcal{X} \in \mathbb{R}^{3n \times n}$, $d_k \in \mathcal{I}[\underline{d}, \bar{d}]$ with \bar{d} and \underline{d} belonging to \mathbb{N}_* , such that*

$$\Psi_i = Q_i + \mathcal{X}\mathcal{B}_i + \mathcal{B}_i^T\mathcal{X}^T < \mathbf{0}; \quad i = 1, \dots, N \tag{20}$$

with

$$Q_i = \begin{bmatrix} P_i & \mathbf{0} & \mathbf{0} \\ \star & \beta Q_i - P_i & \mathbf{0} \\ \star & \star & -Q_i \end{bmatrix} \tag{21}$$

$$\beta = \bar{d} - \underline{d} + 1 \tag{22}$$

and

$$\mathcal{B}_i = [\mathbf{I} - A_i - A_{di}] \tag{23}$$

is verified $\forall \alpha$ admissible, then system (7) subject to (5) is robustly stable. Besides, (14)-(17) is a Lyapunov-Krasovskii function assuring the robust stability of the considered system.

Proof. The positivity of the function (14) is assured with the hypothesis of $P_i = P_i^T > \mathbf{0}$, $Q_i = Q_i^T > \mathbf{0}$. For the equation (14) be a Lyapunov-Krasovskii function, besides its positivity, it is necessary to verify (19) $\forall \alpha \in \Omega$. From hereafter, the α dependency is omitted in the expressions $V_v(k)$, $v = 1, \dots, 3$. To calculate (19), consider

$$\Delta V_1(k) = x_{k+1}^T P(\alpha)x_{k+1} - x_k^T P(\alpha)x_k \tag{24}$$

$$\Delta V_2(k) = x_k^T Q(\alpha)x_k - x_{k-d(k)}^T Q(\alpha)x_{k-d(k)} + \sum_{i=k+1-d(k+1)}^{k-1} x_i^T Q(\alpha)x_i - \sum_{i=k+1-d(k)}^{k-1} x_i^T Q(\alpha)x_i \tag{25}$$

and

$$\Delta V_3(k) = (\bar{d} - \underline{d})x_k^T Q(\alpha)x_k - \sum_{i=k+1-\bar{d}}^{k-\underline{d}} x_i^T Q(\alpha)x_i \tag{26}$$

Observe that the third term in equation (25) can be rewritten as

$$\begin{aligned} \Xi_k &\equiv \sum_{i=k+1-d(k+1)}^{k-1} x_i^T Q(\alpha)x_i = \sum_{i=k+1-\underline{d}}^{k-1} x_i^T Q(\alpha)x_i + \sum_{i=k+1-d(k+1)}^{k-\underline{d}} x_i^T Q(\alpha)x_i \\ &\leq \sum_{i=k+1-d(k)}^{k-1} x_i^T Q(\alpha)x_i + \sum_{i=k+1-\bar{d}}^{k-\underline{d}} x_i^T Q(\alpha)x_i \end{aligned} \tag{27}$$

Using (27) in (25), one gets

$$\Delta V_2(k) \leq x_k^T Q(\alpha) x_k - x_{k-d(k)}^T Q(\alpha) x_{k-d(k)} + \sum_{i=k+1-\bar{d}}^{k-d} x_i^T Q(\alpha) x_i \tag{28}$$

So, considering (24), (26) and (28) the following upper bound for (19) can be obtained

$$\Delta V(k) \leq x_{k+1}^T P(\alpha) x_{k+1} + x_k^T [\beta Q(\alpha) - P(\alpha)] x_k - x_{k-d(k)}^T Q(\alpha) x_{k-d(k)} < 0 \tag{29}$$

Taking into account (7) and using Lemma 1 with

$$\varphi = \xi_k = \left[x_{k+1}^T \quad x_k^T \quad x_{k-d_k}^T \right]^T \tag{30}$$

$$\mathcal{M}(\alpha) = \begin{bmatrix} P(\alpha) & \mathbf{0} & \mathbf{0} \\ \star & \beta Q(\alpha) - P(\alpha) & \mathbf{0} \\ \star & \star & -Q(\alpha) \end{bmatrix} \tag{31}$$

$$\mathcal{G}(\alpha) = \left[\mathbf{I} - A(\alpha) \quad -A_d(\alpha) \right] \tag{32}$$

then (29) is equivalent to

$$\Psi(\alpha) = \mathcal{M}(\alpha) + \mathcal{X}(\alpha)\mathcal{G}(\alpha) + \mathcal{G}(\alpha)^T \mathcal{X}(\alpha)^T < \mathbf{0}. \tag{33}$$

which is assured whenever (20) is verified by taking $\mathcal{X}(\alpha) = \mathcal{X}$,

$$\mathcal{M}(\alpha) = \sum_{i=1}^N \alpha_i \mathcal{Q}_i; \quad \mathcal{G}(\alpha) = \sum_{i=1}^N \alpha_i \mathcal{B}_i, \tag{34}$$

$\alpha \in Y$, \mathcal{Q}_i and \mathcal{B}_i given in (21) and (23), respectively, completing the proof. □

An important issue in Theorem 1 is that there is no product between the matrices of the system and the matrices of the Lyapunov-Krasovskii proposed function, (14). This can be exploited to reduce conservatism in both analysis and synthesis methods.

Example 1 (Stability Analysis). *In this example the stability analysis condition given in Theorem 1 is used to investigate system (7), with $D_w = \mathbf{0}$, where*

$$\tilde{A}_1 = \begin{bmatrix} 0.6 & 0 \\ 0.35 & 0.7 \end{bmatrix} \quad \text{and} \quad \tilde{A}_{d1} = \begin{bmatrix} 0.1 & 0 \\ 0.2 & 0.1 \end{bmatrix}. \tag{35}$$

This system has been investigated by Liu et al. (2006), Boukas (2006) and Leite & Miranda (2008a). The objective here is to establish the larger delay interval such that this system remains stable. The results are summarized in Table 1.

Although Theorem 1 and the condition from Liu et al. (2006) achieve the same upper bound for d_k , the L-K function employed by Liu et al. (2006) has 5 parts while Theorem 1 uses a function with only 3 parts, as given by (14)-(17).

Consider that (35) is affected by an uncertain parameter being described by a polytope (8) with \tilde{A}_1 and \tilde{A}_{d1} given by (35) and $\tilde{A}_2 = 1.1\tilde{A}_1$ and $\tilde{A}_{d2} = 1.1\tilde{A}_{d1}$. In this case the conditions of Boukas (2006) are no longer applicable and those from Liu et al. (2006) are not directly applied, because of type of the system uncertainty. Using Theorem 1 it is possible to assure the robust stability of this system for $|d_{k+1} - d_k| \leq 3$.

Condition	\underline{d}	\bar{d}
Boukas (2006)[Theorem 3.1]	2	10
Liu et al. (2006)	2	13
Theorem 1	2	13

Table 1. Maximum delay intervals such that (7) with (35) is stable.

3.2 Estimation of \mathcal{H}_∞ guaranteed cost

Theorem 2 presented in the sequel states a convex condition for checking if a given γ is an \mathcal{H}_∞ guaranteed cost for system (7).

Theorem 2. *If there exist symmetric matrices $\mathbf{0} < P_i \in \mathbb{R}^{n \times n}$, $\mathbf{0} < Q_i \in \mathbb{R}^{n \times n}$, a matrix $\mathcal{X}_\mathcal{H} \in \mathbb{R}^{3n+p+\ell \times n+p}$, $d_k \in \mathcal{I}[\underline{d}, \bar{d}]$ with \bar{d} and \underline{d} belonging to \mathbb{N}_* , and a scalar $\mu = \gamma^2 \in \mathbb{R}_+$, such that*

$$\Psi_{\mathcal{H}i} = \mathcal{Q}_{\mathcal{H}i} + \mathcal{X}_\mathcal{H} \mathcal{B}_{\mathcal{H}i} + \mathcal{B}_{\mathcal{H}i}^T \mathcal{X}_\mathcal{H}^T < \mathbf{0}, \quad i = 1, \dots, N, \tag{36}$$

with

$$\mathcal{Q}_{\mathcal{H}i} = \begin{bmatrix} Q_i & \mathbf{0} \\ \star & \begin{bmatrix} \mathbf{I}_\ell & \mathbf{0} \\ \star & -\mu \mathbf{I}_p \end{bmatrix} \end{bmatrix} \tag{37}$$

where Q_i is given by (21) and

$$\mathcal{B}_{\mathcal{H}i} = \begin{bmatrix} B_i & \mathbf{0} & B_{wi} \\ \mathbf{0} & \tilde{C}_i & \tilde{C}_{di} \\ \mathbf{0} & \mathbf{0} & -\mathbf{I} & D_{wi} \end{bmatrix} \tag{38}$$

with B_i given by (23), then system (7) subject to (5) with null initial conditions, see (12), is robustly stable with an \mathcal{H}_∞ guaranteed cost given by $\gamma = \sqrt{\mu}$. Besides, (14)-(17) is a L-K function assuring the robust stability of the considered system.

Proof. Following the proof given for Theorem 1, it is possible to conclude that the positivity of (14) is assured with the hypothesis of $P(\alpha) = P(\alpha)^T > \mathbf{0}$, $Q(\alpha) = Q(\alpha)^T > \mathbf{0}$ and, by (29) that

$$\Delta V(k) \leq x'_{k+1} P(\alpha) x_{k+1} + x'_k [\beta Q(\alpha) - P(\alpha)] x_k - x'_{k-d(k)} Q(\alpha) x_{k-d(k)} < 0 \tag{39}$$

Consider system (7) as robustly stable with null initial conditions given by (12), assume $\mu = \gamma^2$ and signals w_k and z_k belonging to ℓ_2 . In this case, it is possible to verify that $V(\alpha, 0) = 0$ and $V(\alpha, \infty)$ approaches zero, whenever w_k goes to zero as k increases, or to a constant $\tilde{\phi} < \infty$, whenever w_k approaches $\phi < \infty$ as k increases. Also, consider the \mathcal{H}_∞ performance index given by

$$J(\alpha, k) = \sum_{k=0}^{\infty} \left[z_k^T z_k - \mu w_k^T w_k \right] \tag{40}$$

Then, using (39), $J(\alpha, k)$ can be over bounded as

$$\begin{aligned} J(\alpha, k) &\leq \sum_{k=0}^{\infty} \left[z_k^T z_k - \mu w_k^T w_k + \Delta V(\alpha, k) \right] \\ &\leq \sum_{k=0}^{\infty} \left[z_k^T z_k - \mu w_k^T w_k + x'_{k+1} P(\alpha) x_{k+1} + x'_k [\beta Q(\alpha) - P(\alpha)] x_k - x'_{k-d(k)} Q(\alpha) x_{k-d(k)} \right] \end{aligned}$$

which can be rewritten as

$$J(\alpha, k) \leq \sum_{k=0}^{\infty} \zeta_k^T \mathcal{Q}_{\mathcal{H}}(\alpha) \zeta_k \tag{41}$$

with $\zeta_k = [\zeta_k^T \ z_k^T \ w_k^T]^T$, ζ_k defined in (30), and $\mathcal{Q}_{\mathcal{H}}(\alpha) = \sum_{i=1}^N \alpha_i \mathcal{Q}_{\mathcal{H}i}$, $\alpha \in Y$. Then, applying Lemma 1 to

$$\zeta_k^T \mathcal{Q}_{\mathcal{H}}(\alpha) \zeta_k < 0 \text{ subject to (7),} \tag{42}$$

with $\mathcal{M}(\alpha) = \mathcal{Q}_{\mathcal{H}}(\alpha)$, $\varphi = \zeta_k$,

$$\mathcal{G}(\alpha) = \mathcal{B}_{\mathcal{H}}(\alpha) = \begin{bmatrix} \mathcal{B}(\alpha) & \mathbf{0} \ B_w(\alpha) \\ \mathbf{0} \ \tilde{\mathcal{C}}(\alpha) \ \tilde{\mathcal{C}}_d(\alpha) & -\mathbf{I} \ D_w(\alpha) \end{bmatrix}, \tag{43}$$

and $\alpha \in Y$, (42) is equivalent to

$$\Psi_{\mathcal{H}}(\alpha) = \mathcal{Q}_{\mathcal{H}}(\alpha) + \mathcal{X}_{\mathcal{H}}(\alpha) \mathcal{B}_{\mathcal{H}}(\alpha) + \mathcal{B}_{\mathcal{H}}(\alpha)^T \mathcal{X}_{\mathcal{H}}(\alpha)^T < \mathbf{0}. \tag{44}$$

Once (36) is verified, (44) is assured with the special choice $\mathcal{X}_{\mathcal{H}}(\alpha) = \mathcal{X}_{\mathcal{H}} \in \mathbb{R}^{3n+p+\ell \times n+p}$ — i.e., eliminating the dependency on the uncertain parameter α — and noting that $\mathcal{G}(\alpha) = \sum_{i=1}^N \alpha_i \mathcal{B}_{\mathcal{H}i}$, convexity is achieved, and (36) can be used to recover (44) by $\Psi_{\mathcal{H}}(\alpha) = \sum_{i=1}^N \alpha_i \Psi_{\mathcal{H}i}$, $\alpha \in Y$. Thus, this assures the negativity of $J(\alpha, k)$ for all $w_k \in \ell_2$ implying that (7) is robustly stable with \mathcal{H}_{∞} guaranteed cost given by $\gamma = \sqrt{\mu}$. \square

In case of time-varying uncertainties, i.e. $\alpha = \alpha_k = \alpha(k)$, the conditions formulated in both Theorem 1 and Theorem 2 can be adapted to match the quadratic stability approach. In this case, it is enough to use $P_i = P$, $Q_i = Q$, $i \in \mathcal{I}[1, N]$. This yields conditions similar to (20) and (36), respectively, with constant L-K matrices. See Subsection (5.1) for a more detailed discussion on this issue.

Note that, it is possible to use the conditions established by Theorem 2 to formulate the following optimization problem that allows to minimize the value of $\mu = \gamma^2$:

$$\mathcal{E}_{\mathcal{H}_{\infty}} : \begin{cases} \min & \mu \\ \text{such that} & P_i > \mathbf{0}; Q_i > \mathbf{0}; \mathcal{X} \end{cases} \tag{45}$$

(36) is feasible

4. Robust \mathcal{H}_{∞} feedback design

The stability analysis conditions can be used to obtain convex synthesis counterpart formulations for designing robust state feedback gains K and K_d , such that control law (6) applied in (1) yields a robustly stable closed-loop system, and, therefore, provides a solution to problems 2 and 4. In this section, such conditions for synthesis are presented for both robust stabilization and robust \mathcal{H}_{∞} control design.

4.1 Robust stabilization

The following Theorem provides some LMI conditions depending on the difference $\bar{d} - \underline{d}$ to design robust state feedback gains K and K_d that assure the robust stability of the closed-loop system.

Theorem 3. *If there exist symmetric matrices $\mathbf{0} < \tilde{P}_i \in \mathbb{R}^{n \times n}$, $\mathbf{0} < \tilde{Q}_i \in \mathbb{R}^{n \times n}$, $i = 1, \dots, N$, matrices $\mathcal{F} \in \mathbb{R}^{n \times n}$, $W \in \mathbb{R}^{m \times n}$ and $W_d \in \mathbb{R}^{m \times n}$, $d_k \in \mathcal{I}[\underline{d}, \bar{d}]$ with \bar{d} and \underline{d} belonging to \mathbb{N}_* , such that*

$$\tilde{\Psi}_i = \begin{bmatrix} \tilde{P}_i + \mathcal{F} + \mathcal{F}^T & -(A_i \mathcal{F} + B_i W) & -(A_{di} \mathcal{F} + B_i W_d) \\ \star & \beta \tilde{Q}_i - \tilde{P}_i & \mathbf{0} \\ \star & \star & -\tilde{Q}_i \end{bmatrix} < \mathbf{0}, \quad i = 1, \dots, N \quad (46)$$

are verified with β given by (22), then system (1)-(3) is robustly stabilizable with (6), where the robust static feedback gains are given by

$$K = W\mathcal{F}^{-1} \quad \text{and} \quad K_d = W_d\mathcal{F}^{-1} \quad (47)$$

yielding a convex solution to Problem 2.

Proof. Observe that, if (46) is feasible, then \mathcal{F} is regular, once block (1, 1) of (46) assures $\tilde{P}_i + \mathcal{F} + \mathcal{F}^T < \mathbf{0}$, allowing to define

$$\mathcal{T} = \mathbf{I}_3 \otimes \mathcal{F}^{-T} \quad (48)$$

Then, by replacing W and W_d by $K\mathcal{F}$ and $K_d\mathcal{F}$, respectively obtained from (47), it is possible to recover $\Psi_i = \mathcal{T}\tilde{\Psi}_i\mathcal{T}^T < \mathbf{0}$ with $\mathcal{X} = [\mathcal{F}^{-T} \mathbf{0} \mathbf{0}]^T$, $P_i = \mathcal{F}^{-T}\tilde{P}_i\mathcal{F}^{-1}$, $Q_i = \mathcal{F}^{-T}\tilde{Q}_i\mathcal{F}^{-1}$ and the closed-loop system matrices $\tilde{A}_i = (A + B_iK)$ and $\tilde{A}_{di} = (A_{di} + B_iK_d)$ replacing A_i and A_{di} in (20), which completes the proof. \square

Note that, conditions in Theorem 3 encompass quadratic stability approach, since it is always possible to choose $P_i = P$ and $Q_i = Q$, $i = 1, \dots, N$. Also observe that, if d_k is not available at each sample-time, and therefore x_{k-d_k} cannot be used in the feedback, then it is enough to choose $W_d = \mathbf{0}$ leading to a control law given by $u_k = Kx_k$. Finally, note the convexity of the conditions stated in Theorem 3. This is a relevant issue, once most of the results available in the literature depend on a nonlinear algorithm to solve the stabilization problem.

Example 2 (Robust Stabilization). *Consider the discrete-time system studied in Leite & Miranda (2008a) with delayed state described by (1) with $D_w = \mathbf{0}$ and*

$$A = \begin{bmatrix} 0 & 1 \\ -2 & -3 \end{bmatrix}; \quad A_d = \begin{bmatrix} 0.01 & 0.1 \\ 0 & 0.1 \end{bmatrix}; \quad B = \begin{bmatrix} 0 \\ 1 \end{bmatrix} \quad (49)$$

Suppose that this system is affected by uncertain parameters $|\rho| \leq 0.07$, $|\theta| \leq 0.1$ and $|\eta| \leq 0.1$, such that

$$A(\rho) = (1 + \rho)A; \quad A_d(\theta) = (1 + \theta)A_d; \quad B(\eta) = (1 + \eta)B \quad (50)$$

These parameters yield a polytope with 8 vertices determined by the combination of the extreme values of ρ , θ and η . Also, suppose that delay is not available on line and it is bounded as $1 \leq d_k \leq 10$. By applying the conditions presented in Theorem 3 with $W_d = \mathbf{0}$ — this is a necessary issue once the delay value is not known at each sample-time — it is possible to get the robust stabilizing gain

$$K = [1.9670 \ 2.7170]. \quad (51)$$

The behavior of the states of the closed-loop response of this uncertain discrete-time system with time-varying delay is shown in Figure 4. It has been simulated the time response of this system at

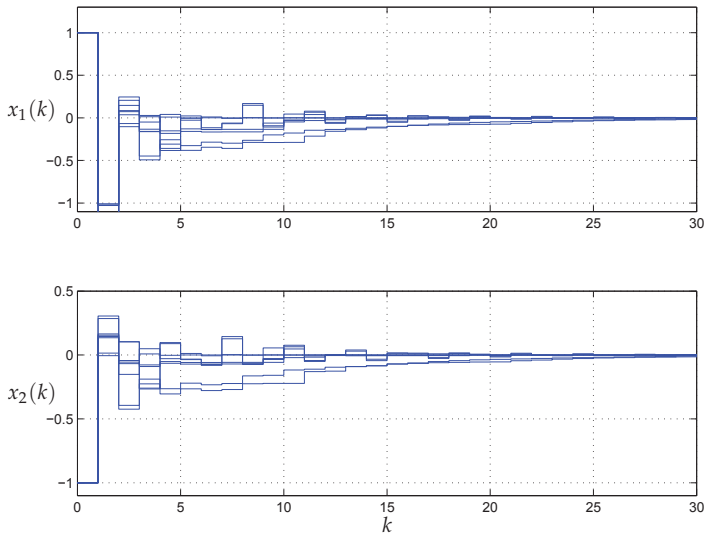

Fig. 1. The behavior of the states $x_1(k)$ (top) and $x_2(k)$ (bottom), with $d_k \in \mathcal{I}[1, 10]$ randomly generated and the robust state feedback gain (51).

each vertex of the polytope that defines the uncertain closed-loop system. The initial conditions have been chosen as

$$\phi_{0,k} = \underbrace{\left\{ \begin{bmatrix} 1 \\ -1 \end{bmatrix}, \dots, \begin{bmatrix} 1 \\ -1 \end{bmatrix} \right\}}_{11 \text{ terms}}$$

and the value of the delay, d_k , has been varied randomly. Please see Leite & Miranda (2008a) for details. In Figure 4, it is illustrated the stability of the uncertain close-loop system, assured by the robust state feedback gain (51).

4.2 Robust \mathcal{H}_∞ feedback design

An stabilization condition assuring the \mathcal{H}_∞ cost of the feedback system is stated in the sequel.

Theorem 4. *If there exist symmetric matrices $\mathbf{0} < \tilde{P}_i \in \mathbb{R}^{n \times n}$, $\mathbf{0} < \tilde{Q}_i \in \mathbb{R}^{n \times n}$, matrices $\mathcal{F} \in \mathbb{R}^{n \times n}$, $W \in \mathbb{R}^{m \times n}$, $W_d \in \mathbb{R}^{m \times n}$, a scalar variable $\theta \in]0, 1]$ and for a given $\mu = \gamma^2 \in \mathbb{R}_+$ such that*

$$\begin{bmatrix} \tilde{P}_i - \mathcal{F} - \mathcal{F}^T & A_i \mathcal{F} + B_i W & A_{di} \mathcal{F} + B_i W_d & \mathbf{0} & B_{wi} \\ * & \beta \tilde{Q}_i - \tilde{P}_i & \mathbf{0} & \mathcal{F}^T C_i^T + W^T D_i^T & \mathbf{0} \\ * & * & -\tilde{Q}_i & \mathcal{F}^T C_{di}^T + W_d^T D_i^T & \mathbf{0} \\ * & * & * & -\theta I & D_{wi} \\ * & * & * & * & -\mu I \end{bmatrix} < \mathbf{0}, \quad i = 1, \dots, N \quad (52)$$

are feasible with β given by (22), then system (1)-(3) is robustly stabilizable with (6) assuring a guaranteed \mathcal{H}_∞ cost given by γ to the closed-loop system by robust state feedback gains K and K_d given by (47).

Proof. To demonstrate the sufficiency of (52), firstly note that, if it is verified, then the regularity of \mathcal{F} is assured due to its block (1,1) that verifies $\tilde{P}_i - \mathcal{F} - \mathcal{F}^T < \mathbf{0}$. Besides, there

exist a real scalar $\kappa \in]0, 2[$ such that for $\theta \in]0, 1]$, $\kappa(\kappa - 2) = -\theta$. Thus, replacing block (4, 4) of (52) by $\kappa(\kappa - 2)\mathbf{I}_p$, the optimization variables W and W_d by $K\mathcal{F}$ and $K_d\mathcal{F}$, respectively, using the definitions given by (10)–(11) and pre- and post-multiplying the resulting LMI by \mathcal{T}_H (on the left) and by \mathcal{T}_H^T (on the right), with

$$\mathcal{T}_H = \begin{bmatrix} \mathcal{T} & \mathbf{0} \\ \star & \begin{bmatrix} G & \mathbf{0} \\ \star & \mathbf{I}_\ell \end{bmatrix} \end{bmatrix}^{-1} \tag{53}$$

with \mathcal{T} given by (48) and $G \in \mathbb{R}^{p \times p}$, it is possible to obtain $\tilde{\Psi}_{Hi} < \mathbf{0}$, with $\tilde{\Psi}_{Hi}$ given by

$$\tilde{\Psi}_{Hi} = \begin{bmatrix} \mathcal{F}^{-T}\tilde{P}_i\mathcal{F}^{-1} - \mathcal{F}^{-T} - \mathcal{F}^{-1} & \mathcal{F}^{-T}(A_i + B_iK) & \mathcal{F}^{-T}(Ad_i + B_iK_d) & \mathbf{0} & FBw & \mathbf{0} \\ \star & \underbrace{\beta\mathcal{F}^{-T}\tilde{Q}_i\mathcal{F}^{-1} - \mathcal{F}^{-T}\tilde{P}_i\mathcal{F}^{-1}}_{\tilde{A}_i} & \underbrace{\mathbf{0}}_{\tilde{A}_{di}} & \mathbf{0} & \mathbf{0} & \mathbf{0} \\ \star & \star & -\mathcal{F}^{-T}\tilde{Q}_i\mathcal{F}^{-1} & \mathbf{0} & \mathbf{0} & \mathbf{0} \\ \star & \star & \star & \star & \mathbf{0} & \mathbf{0} \\ \star & \star & \star & \star & \mathbf{0} & \mathbf{0} \\ \mathbf{0} & \mathbf{0} & \mathbf{0} & \mathbf{0} & \underbrace{(C_i^T + K^T D_i^T)G^T}_{\tilde{C}_i} & \mathbf{0} \\ \mathbf{0} & \mathbf{0} & \mathbf{0} & \mathbf{0} & \underbrace{(Cd_i^T + K_d^T D_i^T)G^T}_{\tilde{C}_{di}} & \mathbf{0} \\ \mathbf{0} & \mathbf{0} & \mathbf{0} & \mathbf{0} & G(\kappa^2 - 2\kappa)G^T & GDw \\ \mathbf{0} & \mathbf{0} & \mathbf{0} & \mathbf{0} & \star & -\mu\mathbf{I}_\ell \end{bmatrix} \tag{54}$$

Observe that, assuming $G = -\frac{1}{\kappa}\mathbf{I}_p$, block (4, 4) of (54) can be rewritten as

$$\begin{aligned} G(\kappa^2 - 2\kappa)G^T &= \left(-\frac{1}{\kappa}\mathbf{I}_p\right)(\kappa^2 - 2\kappa)\left(-\frac{1}{\kappa}\mathbf{I}_p\right) \\ &= \left(1 - \frac{2}{\kappa}\right)\mathbf{I}_p \\ &= \mathbf{I}_p - \frac{1}{\kappa}\mathbf{I}_p - \frac{1}{\kappa}\mathbf{I}_p \\ &= \mathbf{I}_p + G + G^T \end{aligned} \tag{55}$$

assuring the feasibility of $\Psi_{Hi} < \mathbf{0}$ given in (36) with $P_i = \mathcal{F}^{-T}\tilde{P}_i\mathcal{F}^{-1}$, $Q_i = \mathcal{F}^{-T}\tilde{Q}_i\mathcal{F}^{-1}$, $i \in \mathcal{I}[1, N]$, and

$$\mathcal{X}_H = \begin{bmatrix} \mathcal{F}^{-1} & \mathbf{0} \\ \mathbf{0} & \mathbf{0} \\ \mathbf{0} & \mathbf{0} \\ \mathbf{0} & G \\ \mathbf{0} & \mathbf{0} \end{bmatrix}$$

completing the proof. □

Theorem 4 provides a solution to Problem 4. This kind of solution can be efficiently achieved by means of, for example, interior point algorithms. Note that *all* matrices of the system can be affected by polytopic uncertainties which states a difference w.r.t. most of the proposals found in the literature. Another remark concerns the technique used to obtain the synthesis condition: differently from the usual approach for delay free systems, here it is not enough to replace matrices in the analysis conditions with their respective closed-loop versions and to make a linearizing change of variables. This makes clear that the \mathcal{H}_∞ control of systems with delayed state is more complex than with delay free systems. Also, note that the design of state feedback gains K and K_d can be done minimizing the guaranteed \mathcal{H}_∞ cost, $\gamma = \sqrt{\mu}$, of the uncertain closed-loop system. In this case, it is enough to solve the following convex optimization problem:

$$S_{\mathcal{H}_\infty} : \begin{cases} \min & \mu \\ \tilde{P}_i > \mathbf{0}; \tilde{Q}_i > \mathbf{0}; 0 < \theta \leq 1; \\ & W; W_d; F \\ \text{such that} & (52) \text{ is feasible} \end{cases} \quad (56)$$

Example 3 (\mathcal{H}_∞ Design). A physically motivated problem is considered in this example. It consists of a fifth order state space model of an industrial electric heater investigated in Chu (1995). This furnace is divided into five zones, each of them with a thermocouple and a electric heater as indicated in Figure 2. The state variables are the temperatures in each zone (x_1, \dots, x_5), measured by thermocouples, and the control inputs are the electrical power signals (u_1, \dots, u_5) applied to each electric heater. The

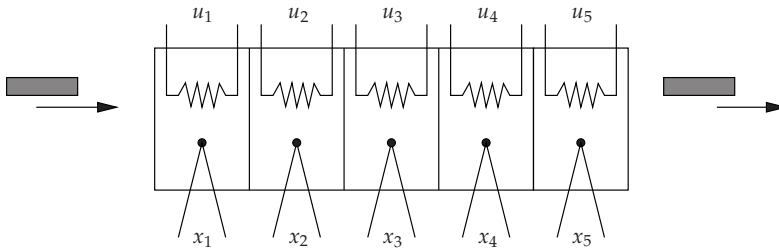

Fig. 2. Schematic diagram of the industrial electric heater.

temperature of each zone of the process must be regulated around its respective nominal operational conditions (see Chu (1995) for details). The dynamics of this system is slow and can be subject to several load disturbances. Also, a time-varying delay can be expected, since the velocity of the displacement of the mass across the furnace may vary. A discrete-time with delayed state model for this system has been obtained as given by (1) with $d_k = d = 15$, where

$$A = A_0 = \begin{bmatrix} 0.97421 & 0.15116 & 0.19667 & -0.05870 & 0.07144 \\ -0.01455 & 0.88914 & 0.26953 & 0.11866 & -0.22047 \\ 0.06376 & 0.12056 & 1.00049 & -0.03491 & -0.02766 \\ -0.05084 & 0.09254 & 0.28774 & 0.82569 & 0.02570 \\ 0.01723 & 0.01939 & 0.29285 & 0.03544 & 0.87111 \end{bmatrix} \quad (57)$$

$$A_d = A_{d0} = \begin{bmatrix} -0.01000 & -0.08837 & -0.06989 & 0.18874 & 0.20505 \\ 0.02363 & 0.03384 & 0.05282 & -0.09906 & -0.00191 \\ -0.04468 & -0.00798 & 0.05618 & 0.00157 & 0.03593 \\ -0.04082 & 0.01153 & -0.07116 & 0.16472 & 0.00083 \\ -0.02537 & 0.03878 & -0.04683 & 0.05665 & -0.03130 \end{bmatrix}, \tag{58}$$

$$B = B_0 = \begin{bmatrix} 0.53706 & -0.11185 & 0.09978 & 0.04652 & 0.25867 \\ -0.51718 & 0.73519 & 0.57518 & 0.40668 & -0.12472 \\ 0.29469 & 0.31528 & 1.16420 & -0.29922 & 0.23883 \\ -0.20191 & 0.19739 & 0.41686 & 0.66551 & 0.11366 \\ -0.11835 & 0.16287 & 0.20378 & 0.23261 & 0.36525 \end{bmatrix}, \tag{59}$$

and $C = D = \mathbf{I}_5$, $C_d = \mathbf{0}$, $D_w = \mathbf{0}$, $B_w = 0.1\mathbf{I}$ with A_0 , A_{d0} , and B_0 being the nominal matrices of this system. Note that, this nominal system has unstable modes. The design of a stabilizing state feedback gain for this system has been considered in Chu (1995) by using optimal control theory, designed by an augmented delay-free system with order equal to 85 and a time-invariant delay $d = 15$, by means of a Riccati equation.

Here, robust \mathcal{H}_∞ state feedback gains are calculated to stabilize this system subject to uncertain parameters given by $|\rho| \leq 0.4$, $|\eta| \leq 0.4$ and $|\sigma| \leq 0.08$ that affect the matrices of the system as follows:

$$A(\rho) = A(1 + \rho), \quad A_d(\theta) = A_d(1 + \theta), \quad B(\sigma) = B(1 + \sigma) \tag{60}$$

This set of uncertainties defines a polytope with 8 vertices, obtained by combination of the upper and lower bounds of uncertain parameters. Also, it is supposed in this example that the system has a time-varying delay given by $10 \leq d_k \leq 20$.

In these conditions, an \mathcal{H}_∞ guaranteed cost $\gamma = 6.37$ can be obtained by applying Theorem 4 that yields the robust state feedback gains presented in the sequel.

$$K = \begin{bmatrix} -2.2587 & -1.0130 & -0.0558 & 0.4113 & 0.9312 \\ -2.0369 & -2.1037 & 0.0822 & 1.5032 & 0.0380 \\ 0.9410 & 0.5645 & -0.7523 & -0.8688 & 0.3801 \\ -0.5796 & -0.2559 & 0.0454 & -1.0495 & 0.4072 \\ -0.0801 & 0.4106 & -0.4369 & 0.5415 & -2.4452 \end{bmatrix} \tag{61}$$

$$K_d = \begin{bmatrix} -0.0625 & 0.2592 & 0.0545 & -0.2603 & -0.5890 \\ -0.1865 & 0.1056 & -0.0508 & 0.1911 & -0.4114 \\ 0.1108 & -0.0460 & -0.0483 & -0.0612 & 0.1551 \\ 0.0309 & 0.0709 & 0.1404 & -0.3511 & -0.1736 \\ 0.0516 & -0.1016 & 0.1324 & -0.0870 & 0.1158 \end{bmatrix} \tag{62}$$

5. Extensions

In this section some extensions to the conditions presented in sections 3 and 4 are presented.

5.1 Quadratic stability approach

The quadratic stability approach is the source of many results of control theory presented in the literature. In such approach, the Lyapunov matrices are taken constant and independent of the uncertain parameter. As a consequence, their achieved results may be very conservative, specially when applied to uncertain time-invariant systems. See, for instance, the works of Leite & Peres (2003), de Oliveira et al. (2002) and Leite et al. (2004). Perhaps the main

advantages of the quadratic stability approach are the simple formulation — with low numerical complexity — and the possibility to deal with time-varying systems. In this case, all equations given in Section 2 can be reformulated by using time-dependency on the uncertain parameter, i.e., by using $\alpha = \alpha_k$. In special, the uncertain open-loop system (1) can be described by

$$\Omega_v(\alpha_k) : \begin{cases} x_{k+1} = A(\alpha_k)x_k + A_d(\alpha_k)x_{k-d_k} + B(\alpha_k)u_k + B_w(\alpha_k)w_k, \\ z_k = C(\alpha_k)x_k + C_d(\alpha_k)x_{k-d_k} + D(\alpha_k)u_k + D_w(\alpha_k)w_k, \end{cases} \quad (63)$$

with $\alpha_k \in Y_v$

$$Y_v = \left\{ \alpha_k : \sum_{i=1}^N \alpha_{ki} = 1, \alpha_{ki} \geq 0, i \in \mathcal{I}[1, N] \right\} \quad (64)$$

which allows to define the polytope \mathcal{P} given in (2) with α_k replacing α . Still considering control law (6), the resulting closed-loop system is given by

$$\tilde{\Omega}_v(\alpha_k) : \begin{cases} x_{k+1} = \tilde{A}(\alpha_k)x_k + \tilde{A}_d(\alpha_k)x_{k-d_k} + B_w(\alpha_k)w_k, \\ z_k = \tilde{C}(\alpha_k)x_k + \tilde{C}_d(\alpha_k)x_{k-d_k} + D_w(\alpha_k)w_k, \end{cases} \quad (65)$$

with $\tilde{\Omega}_v(\alpha_k) \in \tilde{\mathcal{P}}$ given in (8) with α_k replacing α .

The convex conditions presented can be simplified to match with quadratic stability formulation. This can be done in the analysis cases by imposing $P_i = P > \mathbf{0}$ and $Q_i = Q > \mathbf{0}$ in (20) and (36) and, in the synthesis cases, by imposing $\tilde{P}_i = \tilde{P} > \mathbf{0}$, $\tilde{Q}_i = \tilde{Q} > \mathbf{0}$, $i = 1, \dots, N$. This procedure allows to establish the following Corollary.

Corollary 1 (Quadratic stability). *The following statements are equivalent and sufficient for the quadratic stability of system $\tilde{\Omega}_v(\alpha_k)$ given in (65):*

- i) *There exist symmetric matrices $\mathbf{0} < P \in \mathbb{R}^{n \times n}$, $\mathbf{0} < Q \in \mathbb{R}^{n \times n}$, matrices $F \in \mathbb{R}^{n \times n}$, $G \in \mathbb{R}^{n \times n}$ and $H \in \mathbb{R}^{n \times n} \in \mathbb{R}^{n \times n}$, $d_k \in \mathcal{I}[\underline{d}, \bar{d}]$ with \bar{d} and \underline{d} belonging to \mathbb{N}_* , such that*

$$\Psi_{qi} = \begin{bmatrix} P + F^T + F & G^T - FA_i & H^T - FA_{di} \\ * & \beta Q - P - A_i^T G^T - GA_i & -A_i^T H^T - G^T A_{di} \\ * & * & -(Q + HA_{di} + A_{di}^T H^T) \end{bmatrix} < \mathbf{0}, \quad (66)$$

is verified for $i = 1, \dots, N$.

- ii) *There exist symmetric matrices $\mathbf{0} < P \in \mathbb{R}^{n \times n}$, $\mathbf{0} < Q \in \mathbb{R}^{n \times n}$, $d_k \in \mathcal{I}[\underline{d}, \bar{d}]$ with \bar{d} and \underline{d} belonging to \mathbb{N}_* , such that*

$$\Phi_i = \begin{bmatrix} A_i^T P A_i + \beta Q - P & A_i^T P A_{di} \\ * & A_{di}^T P A_{di} - Q \end{bmatrix} < \mathbf{0} \quad (67)$$

is verified for $i = 1, \dots, N$.

Proof. Condition (66) can be obtained from (20) by imposing $P_i = P > \mathbf{0}$ and $Q_i = Q > \mathbf{0}$. This leads to a Lyapunov-Krasovskii function given by

$$V(x_k) = x_k' P x_k + \sum_{j=k-d(k)}^{k-1} x_j' Q x_j + \sum_{\ell=2-\bar{d}}^{1-\underline{d}} \sum_{j=k+\ell-1}^{k-1} x_j' Q x_j$$

which is sufficient for the quadratic stability of $\tilde{\Omega}_v(\alpha_k)$. This condition is not necessary for the quadratic stability because this function is also not necessary, even for the stability of the precisely known system. The equivalence between (66) and (67) can be stated as follows: $i) \Rightarrow ii)$ if (66) is verified, then (67) can be recovered by $\Phi_i = \mathcal{T}_{qi}^T \Psi_{qi} \mathcal{T}_{qi}$ with

$$\mathcal{T}_{qi} = \begin{bmatrix} A_i & A_{di} \\ \mathbf{I}_{2n} & \mathbf{0} \end{bmatrix}$$

$ii) \Leftarrow i)$ On the other hand, if (67) is verified, then it is possible by its Schur's complement to obtain

$$\Phi_i < \mathbf{0} \Leftrightarrow \begin{bmatrix} -P & PA_i & PA_{di} \\ * & \beta Q - P & \mathbf{0} \\ * & * & -Q \end{bmatrix} < \mathbf{0}, \quad i = 1, \dots, N \tag{68}$$

which assures the feasibility of (66) with $F = -P, G = H = \mathbf{0}$, completing the proof. \square

It is possible to obtain quadratic stability conditions corresponding to each of the formulations presented by theorems 2, 3, 4 following similar steps of those taken to obtain Corollary 1. However, due to the straight way to obtain such conditions, they are not shown here. Nevertheless, quadratic stability based conditions may lead to results that are, in general, more conservative than those achieved by similar formulations that employ parameter dependent Lyapunov-Krasovskii functions.

5.2 Actuator failure

Partial or total actuator failures are important issues on real word systems and the formulations presented in this chapter can also be used to investigate the robust stability as well as to design robust state feedback control gains assuring stability and \mathcal{H}_∞ guaranteed performance for the uncertain closed-loop system under such failures. The robustness against actuator failures plays an important role in industry, representing not only an improvement in the performance of the closed-loop system, but also a crucial security issue in many plants Leite et al. (2009). In this case, the problem of actuator failures is cast as a special type of uncertainty affecting the input matrix B , being modeled as $B\rho(t)$, with $\rho(t) \in \mathcal{I}[0,1]$. If $\rho(t) = 1$, then the actuator is perfectly working. On the other hand, when the value of $\rho(t)$ is reduced, it means that the actuator cannot delivery all energy required by the control law. The limit is when $\rho(t) = 0$, meaning that the actuator is off. Once the actuator failure implies on time-varying matrix $B(\alpha)$, i.e., $B(\alpha_k)$, it is necessary to employ quadratic stability approach, as described in subsection 5.1.

5.3 Switched systems with delayed state

Another class of time-varying systems is composed by the discrete-time switched systems with delay in the state vector. In this case the system can be described by

$$x_{k+1} = A(\alpha_k)x_k + A_d(\alpha_k)x_{k-d_k} + B(\alpha_k)u(\alpha_k) \tag{69}$$

with adequate initial conditions and the uncertain parameter $\alpha_k = \alpha(k)$ is

$$\alpha_i(k) = \begin{cases} 1, & \text{for } i = \sigma_k \\ 0, & \text{otherwise} \end{cases} \tag{70}$$

and σ_k is an arbitrary switching function defined as

$$\sigma_k : \mathbb{N} \rightarrow \mathcal{I}[1, N] \tag{71}$$

where N is the number of subsystems. The matrices $[A(\alpha_k)|A_d(\alpha_k)|B(\alpha_k)] \in \mathbb{R}^{n \times 2n+m}$ are switched matrices depending on the switching function (71) and can be written as the vertices of the polytope defined by the set of submodes of the system. Naturally, except the vertices, no element of this polytope is reached by the system. Therefore, function σ_k can select one of the subsystems $[A|A_d|B]_i, i = 1, \dots, N$, at each instant k . Those definitions can be done with all other matrices presented in (69) or (65).

It is usual to take the following hypothesis when dealing with switched delay systems:

Hypothesis 1. *The switching function is not known a priori, but it is available at each sample-time, k .*

Hypothesis 2. *All matrices of system (69) (or mutatis mutandis (65)) are switched simultaneously by (71).*

Hypothesis 3. *Both state vectors, x_k and x_{k-d_k} , are available for feedback.*

These hypotheses can be considered on both stabilization and \mathcal{H}_∞ control problems proposed in sections 3 and 4. An important difference w.r.t. the main stabilization problems investigated in this chapter is that, if σ_k is known, it is reasonable to use also a switched control law given by

$$u_k = K(\alpha_k)x_k + K_d(\alpha_k)x_{k-d_k} \tag{72}$$

where the gains $K(\alpha_k)$ and $K_d(\alpha_k)$ are considered to stabilize the respective subsystem $i, i = 1, \dots, N$, and assure stable transitions $\sigma_k \rightarrow \sigma_{k+1}$. Thus, the switched closed-loop system may be stabilizable by a solution of this problem, being written as in (65) with

$$\tilde{A}(\alpha_k) \equiv A(\alpha_k) + B(\alpha_k)K(\alpha_k) \quad \tilde{A}_d(\alpha_k) \equiv A_d(\alpha_k) + B(\alpha_k)K_d(\alpha_k) \tag{73}$$

The stability of the closed-loop system can be tested with the theorem presented in the sequel.

Theorem 5. *If there exist symmetric matrices $\mathbf{0} < P_i \in \mathbb{R}^{n \times n}, \mathbf{0} < Q_i \in \mathbb{R}^{n \times n}$, matrices $F_i \in \mathbb{R}^{n \times n}, G_i \in \mathbb{R}^{n \times n}$ and $H_i \in \mathbb{R}^{n \times n}, i = 1, \dots, N$, and a scalar $\beta = \bar{d} - \underline{d} + 1$, with \underline{d} and \bar{d} known, such that*

$$\begin{bmatrix} P_j + F_j^T + F_j & G_i^T - F_i A_i & H_i^T - F_i A_{di} \\ \star & \beta Q_i - P_i - A_i^T G_i^T - G_i A_i & -A_i^T H_i^T - G_i A_{di} \\ \star & \star & -(Q_\ell + H_i A_{di} + A_{di}^T H_i^T) \end{bmatrix} < \mathbf{0}, \tag{74}$$

for $(i, j, \ell) \in \mathcal{I}[1, N] \times \mathcal{I}[1, N] \times \mathcal{I}[1, N]$, then the switched time-varying delay system (69)-(73) with $u_k = \mathbf{0}$ is stable for arbitrary switching function σ_k .

As it can be noted, a relevant issue of (74) is that the extra matrices are also dependent on the switching function σ_k . This condition can be casted in a similar form of (20) as follows

$$\Psi_{\sigma_i, j, \ell} = Q_{i, j, \ell} + \mathcal{X}_i \mathcal{B}_i + \mathcal{B}_i^T \mathcal{X}_i^T < \mathbf{0}, \quad (i, j, \ell) \in \mathcal{I}[1, N] \times \mathcal{I}[1, N] \times \mathcal{I}[1, N] \tag{75}$$

where

$$Q_{i, j, \ell} = \begin{bmatrix} P_j & \mathbf{0} & \mathbf{0} \\ \star & \beta Q_i - P_i & \mathbf{0} \\ \star & \star & -Q_\ell \end{bmatrix}.$$

The synthesis case, i.e. to solve the problem of designing K_i and $K_{di}, i = 1, \dots, N$, such that the (69)–(72) is robustly stable, is presented in the following theorem.

Theorem 6. *If there exist symmetric matrices $\mathbf{0} < P_i \in \mathbb{R}^{n \times n}$, $\mathbf{0} < Q_i \in \mathbb{R}^{n \times n}$, matrices $F_i \in \mathbb{R}^{n \times n}$, $W_i \in \mathbb{R}^{n \times \ell}$ and $W_{di} \in \mathbb{R}^{n \times \ell}$, $i = 1, \dots, N$, and a scalar $\beta = \bar{d} - \underline{d} + 1$, with \underline{d} and \bar{d} known, such that*

$$\Psi_i = \begin{bmatrix} \tilde{P}_j + \mathcal{F}_i + \mathcal{F}_i^T - (A_i \mathcal{F}_i + B_i W_i) - (A_{di} \mathcal{F}_i + B_i W_{di}) & & \\ \star & \beta \tilde{Q}_i - \tilde{P}_i & \mathbf{0} \\ \star & \star & -\tilde{Q}_\ell \end{bmatrix} < \mathbf{0}, \tag{76}$$

for $(i, j, \ell) \in \mathcal{I}[1, N] \times \mathcal{I}[1, N] \times \mathcal{I}[1, N]$, then the switched system with time-varying delay (69) is robustly stabilizable by the control law (72) with

$$K_i = W_i F_i^{-1} \quad \text{and} \quad K_{di} = W_{di} F_i^{-1} \tag{77}$$

The proof of theorems 5 and 6 can be found in Leite & Miranda (2008b) and are omitted here. An important issue of Theorem 6 is the use of one matrix \mathcal{X}_i for each submode. This is possible because of the switched nature of the system that reaches only the vertices of the polytope.

Example 4. *Consider the switched discrete-time system with time varying delay described by (69) where where $A(\sigma_k) = A_n + (-1)^{\sigma_k} \rho L' J$, $A_d(\sigma_k) = (0.225 + (-1)^{\sigma_k} 0.025) A_n$ and*

$$B(\sigma_k) = [0 \ 1.5 \ 0 \ 1.5]' + (-1)^{\sigma_k} [0 \ 0.5 \ 0 \ 0.5]'$$

with

$$A_n = \begin{bmatrix} 0.8 & -0.25 & 0 & 1 \\ 1 & 0 & 0 & 0 \\ 0 & 0 & 0.2 & 0.03 \\ 0 & 0 & 1 & 0 \end{bmatrix} \tag{78}$$

$L = [0, 0, 1, 0]'$, $J = [0.8, -0.5, 0, 1]$, $\sigma_k \in \{1, 2\}$, $\rho = 0.35$. This system with 2 submodes has been investigated by Leite & Miranda (2008b). Note that, even for $\underline{d} = \bar{d} = 1$, conditions from Theorem 5 fail to identify this system as a stable one. Observe that, once the delay is time-varying, conditions presented in Montagner et al. (2005), Phat (2005) and Yu et al. (2007) cannot be applied. Supposing $\underline{d} = 1$, a search on \bar{d} has been done to find its maximum value such that the considered system is stabilizable. Two alternatives are pursued: firstly, consider that only x_k is available for feedback, i.e., $K_d = \mathbf{0}$. Conditions of Theorem 6 are feasible until $\bar{d} = 15$, for which value it is possible to determine the following gains:

$$K_{Th\ 6,1} = [0.1215 \ 0.0475 \ -1.6326 \ -0.4744]$$

$$K_{Th\ 6,2} = [-0.1494 \ 0.1551 \ -0.8168 \ -0.5002]$$

Secondly, consider that both x_k and x_{k-d_k} are available for feedback. By using Theorem 6 it is possible to stabilize the switched system for $1 \leq \bar{d}_k \leq 335$. In this case, with $\bar{d} = 335$, conditions of Theorem 6 lead to

$$K_1 = [-0.6129 \ 0.3269 \ -1.2873 \ -1.1935] \tag{79}$$

$$K_2 = [-0.2199 \ 0.1107 \ -0.6450 \ -0.4890] \tag{80}$$

$$K_{d1} = [-0.1291 \ 0.0677 \ -0.3228 \ -0.2685] \tag{81}$$

$$K_{d2} = [-0.0518 \ 0.0271 \ -0.1291 \ -0.1076] \tag{82}$$

These gains are used in a numerical simulation where random signals for $\sigma_k \in \{1, 2\}$ and for $1 \leq d(k) \leq 335$ have been generated as indicated in Figure 3. The initial condition used in this simulation

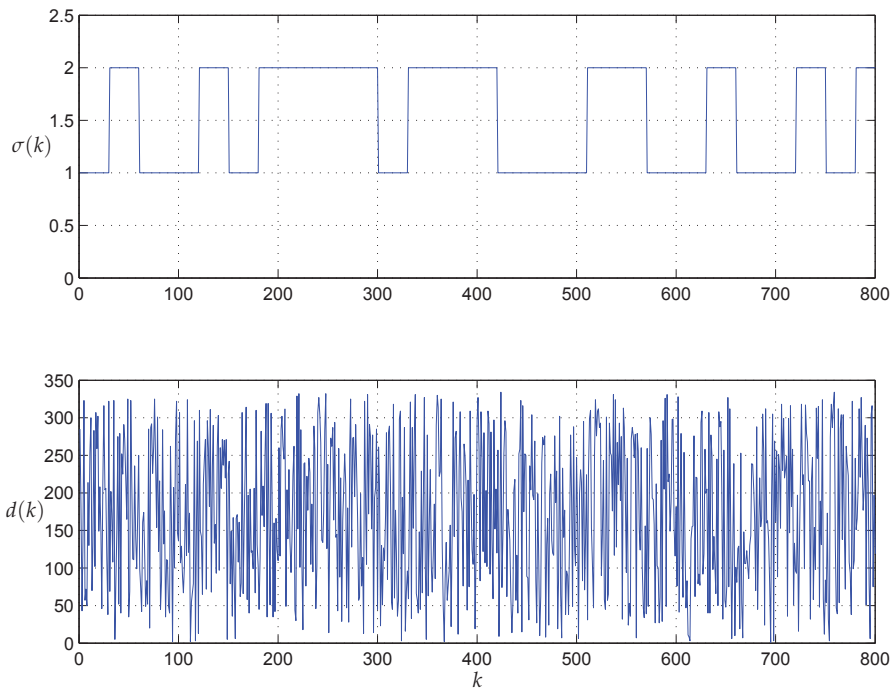

Fig. 3. The switched function, $\sigma(k)$ and the varying delay, d_k .

is

$$\phi_{0,k} = \underbrace{\left\{ \begin{bmatrix} 1 \\ -1 \\ 1 \\ -1 \end{bmatrix}, \dots, \begin{bmatrix} 1 \\ -1 \\ 1 \\ -1 \end{bmatrix} \right\}}_{336 \text{ terms}}$$

Thus, it is expected that the delayed state degenerate the overall system response, at least for the first $\bar{d} = 335$ samples, since it is like an impulsive state action arrives at each sample instant for $0 \leq k \leq 335$. Note that, this initial condition is harder than the ones usually found in the literature. The state behavior of the switched closed-loop system with time-varying delay is presented in Figure 4. Observe that the initial value of the state are not presented due to the scale choice. As can be noted by the response behavior presented in Figure 4, the states are almost at the equilibrium point after 400 samples. The control signal is presented in Figure 5. In the top part of this figure, it is shown the control signal part due to $K_{\sigma_k}x(k)$ and in the bottom the control signal due to $K_{d\sigma_k}x(k - d_k)$. The actual control signal is, thus, the addition of these two signals. If quadratic stability is used in the system of this example, the results are more conservative as can be seen in Leite & Miranda (2008b).

5.4 Decentralized control

It is interesting to note that the synthesis conditions proposed in this chapter, i.e. theorems 3, 4, 6 as well as the convex optimization problem $\mathcal{S}_{\mathcal{H}_\infty}$, can be easily used to design decentralized

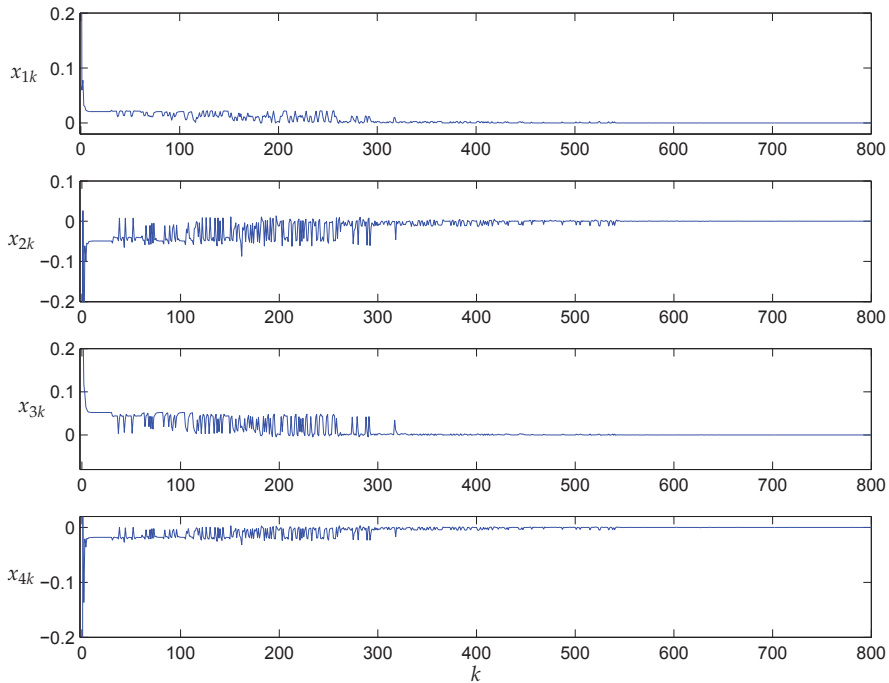

Fig. 4. The behaviors of the states x_{1k} to x_{4k} , with $1 \leq d(k) \leq 335$ (see Fig. 3).

control gains. This kind of control gain is usually employed when interconnected systems must be controlled by means of local information only. In this case, decentralized control gains $K = K_D$ and $K_d = K_{dD}$ can be obtained by imposing block-diagonal structure to matrices W , W_d and \mathcal{F} as follows

$$\begin{aligned} W &= W_D = \text{block-diag}\{W^1, \dots, W^q\}, \\ W_d &= W_{dD} = \text{block-diag}\{W_d^1, \dots, W_d^q\}, \\ \mathcal{F} &= \mathcal{F}_D = \text{block-diag}\{\mathcal{F}^1, \dots, \mathcal{F}^q\} \end{aligned}$$

where q denote the number of defined subsystems. In this case, it is possible to get robust block-diagonal state feedback gains $K_D = W_D \mathcal{F}_D^{-1}$ and $K_{dD} = W_{dD} \mathcal{F}_D^{-1}$. It is worth to mention that the matrices of the Lyapunov-Krasovskii function, $\tilde{P}(\alpha)$ and $\tilde{Q}(\alpha)$, do not have any restrictions in their structures, which may leads to less conservative designs.

5.5 Static output feedback

When only a linear combination of the states is available for feedback and the output signal is given by $y_k = \tilde{C}x_k$, it may be necessary to use the static output feedback. See the survey made by Syrmos et al. (1997) on this subject. In case of \tilde{C} with full row rank, it is always possible to find a regular matrix L such that $\tilde{C}L^{-1} = [\mathbf{I}_p \mid \mathbf{0}]$. Using such matrix L in a similarity transformation applied to (1) it yields

$$\hat{x}_{k+1} = \hat{A}(\alpha)\hat{x}_k + \hat{A}_d(\alpha)\hat{x}_{k-d_k} + \hat{B}(\alpha)u_k, \tag{83}$$

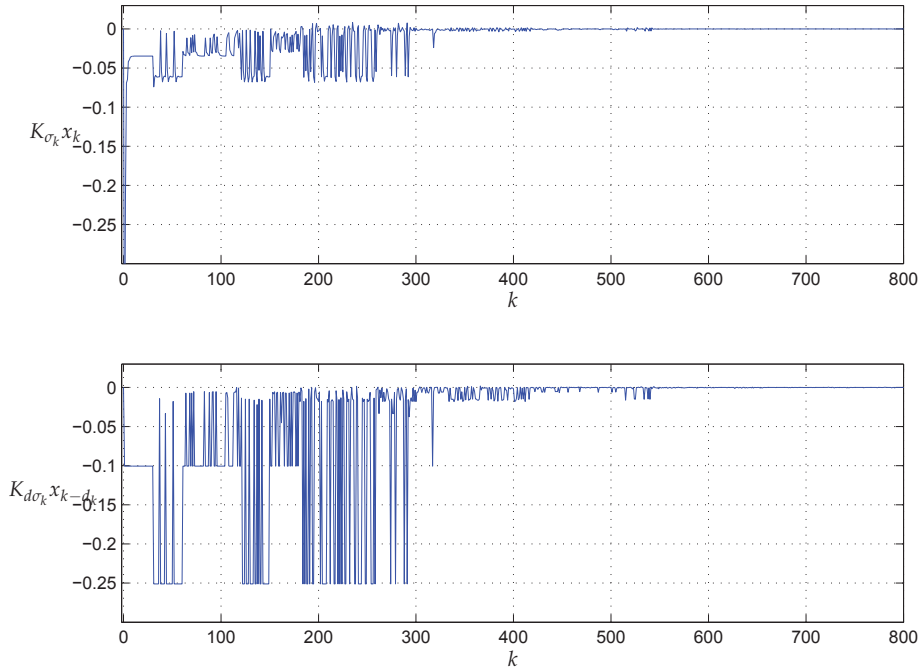

Fig. 5. Control signal $u_k = K_{\sigma_k} x_k + K_{d,\sigma_k} x_{k-d_k}$, with $K_{\sigma_k} x_k$ and $K_{d,\sigma_k} x_{k-d_k}$ shown in the top and bottom parts, respectively.

where $\hat{A}(\alpha) = L\tilde{A}(\alpha)L^{-1}$, $\hat{A}_d(\alpha) = L\tilde{A}_d(\alpha)L^{-1}$ and $\hat{B}(\alpha) = L\tilde{B}(\alpha)$, $\hat{x}_k = Lx_k$ and the output signal is given by $y_k = [\mathbf{I}_p \mathbf{0}] \hat{x}_k$. Thus, the objective here is to find robust static feedback gains $\mathcal{K} \in \mathbb{R}^{p \times \ell}$ and $\mathcal{K}_d \in \mathbb{R}^{p \times \ell}$ such that (83) is robustly stabilizable by the control law

$$u_k = \mathcal{K}y_k + \mathcal{K}_d y_{k-d_k} \tag{84}$$

These gains can be determined by using the conditions of theorems 3, 4, 6 with the following structures

$$\mathcal{F} = \left[\begin{array}{c|c} \mathcal{F}_o^{11} & \mathbf{0} \\ \hline \mathcal{F}_o^{21} & \mathcal{F}_o^{22} \end{array} \right], \quad W = [W_{\mathcal{K}} \mathbf{0}], \quad W_d = [W_{\mathcal{K}_d} \mathbf{0}]$$

with $\mathcal{F}_o^{11} \in \mathbb{R}^{p \times p}$, $\mathcal{F}_o^{21} \in \mathbb{R}^{(n-p) \times p}$, $\mathcal{F}_o^{22} \in \mathbb{R}^{(n-p) \times (n-p)}$, $W_{\mathcal{K}} \in \mathbb{R}^{p \times n}$, $W_{\mathcal{K}_d} \in \mathbb{R}^{p \times n}$ which yields

$$K = [\mathcal{K} \mathbf{0}] \quad \text{and} \quad K_d = [\mathcal{K}_d \mathbf{0}]$$

Note that, similarly to the decentralized case, no constraint is taken over the Lyapunov-Krasovskii function matrices leading to less conservative conditions, in general.

5.6 Input delay

Another relevant issue in Control Theory is the study of stability and stabilization of input delay systems, which is quite frequent in many real systems Yu & Gao (2001), Chen et al.

(2004). In this case, consider the controlled system given by

$$x_{k+1} = A(\alpha)x_k + B(\alpha)u_{k-d_k} \quad (85)$$

with $A(\alpha)$ and $B(\alpha)$ belonging to polytope (2), $A_{di} = \mathbf{0}$ and $\alpha \in Y$. In Zhang et al. (2007) this system is detailed investigated and the problem is converted into an optimization problem in Krein space with an stochastic model associated. Here, the delayed input control signal is considered as

$$u_{k-d_k} = K_d x_{k-d_k} \quad (86)$$

The closed-loop-system is given by

$$x_{k+1} = \tilde{A}(\alpha)x_k + \tilde{A}_d(\alpha)x_{k-d_k} \quad (87)$$

with $\tilde{A}(\alpha) = A(\alpha)$, $\tilde{A}_d(\alpha) = B(\alpha)K_d$. Thus, with known K_d , closed-loop system (87) is equivalent to (7) with null exogenous signal w_k . This leads to simple analysis stability conditions obtained from Theorem 1 replacing \tilde{A}_i by A_i and \tilde{A}_{di} by $B_i K_d$, $i = 1, \dots, N$. Besides, similar replacements can be used with conditions presented in theorems 2 and 5 and in Corollary 1. The possibility to address both controller fragility and input delay is a side result of this proposal. In the former it is required that no uncertainty affects the input matrix, i.e., $B(\alpha) = B$, $\forall \alpha \in Y$, while the latter can be used to investigate the bounds of stability of a closed-loop system with a delay due to, for example, digital processing or information propagation.

In case of the design of K_d it is possible to take similar steps with conditions of theorems 3, 4 and 6. In this case, it is sufficient to impose, $A_{di} = \mathbf{0}$, $i = 1, \dots, N$ and $W = \mathbf{0}$ that yield $K = \mathbf{0}$. Finally, observe that static delayed output feedback control can be additionally addressed here by considering what is pointed out in Subsection 5.5.

5.7 Performance by delay-free model specification

Some well developed techniques related to model-following control (or internal model control) can be applied in the context of delayed state systems. The major advantage of such techniques for delayed systems concerns with the design with performance specification based on zero-pole location. See, for example, the works of Mao & Chu (2009) and Silva et al. (2009). Generally, the model-following control design is related to an input-output closed-loop model, specified from its poles, zeros and static gain, from which the controller is calculated. As the proposal presented in this chapter is based on state feedback control, it does not match entirely with the requirements for following-model, because doing state feedback only the poles can be redesigned, but not the zeros and the static gain. To develop a complete following model approach an usual way is to deal with output feedback, that yields a non-convex formulation. One way to match all the requirements of following model by using state feedback and maintaining the convexity of the formulation, is to use the technique presented by Coutinho et al. (2009) where the model to be matched is separated into two parts: One of them is used to couple the static gain and zeros of the closed loop system with the prescribed model and the other part is matched by state feedback control. Consider the block diagram presented in Figure 6. In this figure, $\Omega(\alpha)$ is the system to controlled with signal u_k . This system is subject to input w_k which is required to be reject at the output y_k . Please, see equation (1). Ω_m stands for a specified delay-free model with realization given by $\begin{bmatrix} A_m & B_m \\ C_m & D_m \end{bmatrix}$. The model receives the same exogenous input of the system to be controlled, w_k , and has an output signal y_{mk} at the instant k .

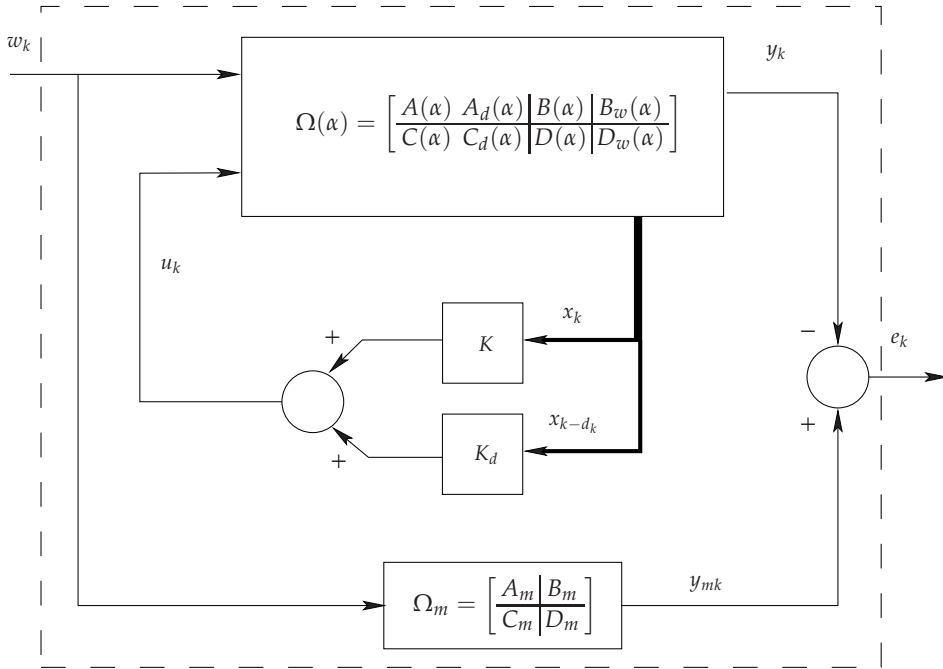

Fig. 6. Following model inspired problem.

The objective here is to design robust state feedback gains K and K_d to implement the control law (6) such that the \mathcal{H}_∞ guaranteed cost between the input w_k and the output $e_k = y_k - y_{mk}$ is minimized. In other words, it is desired that the disturbance rejection of the uncertain system with time-varying delay in the state have a behavior as close as possible to the behavior of the specified delay-free model Ω_m . The dashed line in Figure 6 identifies the enlarged system required to have its \mathcal{H}_∞ guaranteed cost minimized.

Taking the closed-loop system (7) and the specified model of perturbation rejection given by

$$x_{mk+1} = A_m x_{mk} + B_m w_k \tag{88}$$

$$y_{mk} = C_m x_{mk} + D_m w_k \tag{89}$$

where $x_{mk} \in \mathbb{R}^{n_m}$ is the model state vector at the k -th sample-time, $y_{mk} \in \mathbb{R}^p$ is the output of the model at the same sample-time and $w_k \in \mathbb{R}^\ell$ is the same perturbation affecting the controlled system, the difference $e_k = y_{mk} - z_k$ is obtained as

$$e_k = \begin{bmatrix} C_m & -(C(\alpha) + D(\alpha)K) & -(C_d(\alpha) + D(\alpha)K_d) \end{bmatrix} \begin{bmatrix} x_{mk} \\ x_k \\ x_{k-d_k} \end{bmatrix} + [D_m - D_w(\alpha)] w_k \tag{90}$$

Thus, by using (1) with (88)-(89) and (90) it is possible to construct an augmented system composed by the state of the system and those from model yielding the following system

$$\hat{\Omega}(\alpha) : \begin{cases} \hat{x}_{k+1} = \hat{A}(\alpha)\hat{x}_k + \hat{A}_d(\alpha)\hat{x}_{k-d_k} + \hat{B}_w(\alpha)w_k \\ e_k = \hat{C}(\alpha)\hat{x}_k + \hat{C}_d(\alpha)\hat{x}_{k-d_k} + \hat{D}_w(\alpha)w_k \end{cases} \tag{91}$$

with $\hat{x}_k = [x_{mk}^T \ x_k^T]^T \in \mathbb{R}^{n_m+n}$, $\hat{\Omega}(\alpha) \in \hat{\mathcal{P}}$,

$$\hat{\mathcal{P}} = \left\{ \hat{\Omega}(\alpha) \in \mathbb{R}^{n+n_m+p \times 2(n+n_m)+\ell} : \hat{\Omega}(\alpha) = \sum_{i=1}^N \alpha_i \hat{\Omega}_i, \alpha \in Y \right\} \tag{92}$$

where

$$\begin{aligned} \hat{\Omega}_i &= \left[\begin{array}{c|c} \hat{A}_i & \hat{A}_{di} \\ \hline \hat{C}_i & \hat{C}_{di} \end{array} \middle| \begin{array}{c} \hat{B}_{wi} \\ \hline \hat{D}_{wi} \end{array} \right] \\ &= \left[\begin{array}{cc|cc|c} A_m & \mathbf{0} & \mathbf{0} & \mathbf{0} & B_m \\ \mathbf{0} & A_i + B_i K & \mathbf{0} & A_{di} + B_i K_d & B_{wi} \\ \hline C_m - (C_i + D_i K) & \mathbf{0} & -(C_{di} + D_i K_d) & D_m - D_{wi} & \end{array} \right], \quad i \in \mathcal{I}[1, N]. \end{aligned} \tag{93}$$

Therefore, matrices in (93) — $\hat{A}_i, \hat{A}_{di}, \hat{B}_{wi}, \hat{C}_i, \hat{C}_{di}, \hat{D}_{wi}$ — can be used to replace their respective in (38) and (23). As a consequence, LMI (36) becomes with $3(n + n_m) + 2(p + \ell)$ rows. Since the main interest in this section is to design K and K_d that minimize the \mathcal{H}_∞ guaranteed cost between e_k and w_k , only the design condition is presented in the sequel. To achieve such condition, similar steps of those taken in the proof of Theorem 4 are taken. The main differences are related to *i*) the size and structure of the matrices and *ii*) the manipulations done to keep the convexity of the formulation.

Theorem 7. *If there exist symmetric matrices $\mathbf{0} < \tilde{P}_i = \begin{bmatrix} \tilde{P}_{11i} & \tilde{P}_{12i} \\ \star & \tilde{P}_{22i} \end{bmatrix} \in \mathbb{R}^{n+n_m \times n+n_m}$, $\mathbf{0} < \tilde{Q}_i = \begin{bmatrix} \tilde{Q}_{11i} & \tilde{Q}_{12i} \\ \star & \tilde{Q}_{22i} \end{bmatrix} \in \mathbb{R}^{n+n_m \times n+n_m}$, matrices $\mathcal{F} = \begin{bmatrix} \mathcal{F}_{11} & \mathcal{F}_{12} \\ \mathcal{F}_{22} \Lambda & \mathcal{F}_{22} \end{bmatrix} \in \mathbb{R}^{n+n_m \times n+n_m}$, $\Lambda \in \mathbb{R}^{n \times n_m}$ is a given matrix, $W \in \mathbb{R}^{p \times n}$, $W_d \in \mathbb{R}^{p \times n}$, a scalar variable $\theta \in]0, 1]$ and for a given $\mu = \gamma^2$ such that*

$$\begin{aligned} \tilde{\Psi}_i &= \left[\begin{array}{cccc} \tilde{P}_{11i} - \mathcal{F}_{11} - \mathcal{F}_{11}^T & \tilde{P}_{12i} - \mathcal{F}_{12} - \Lambda^T \mathcal{F}_{22}^T & A_m \mathcal{F}_{11} & A_m \mathcal{F}_{12} \\ \star & \tilde{P}_{22i} - \mathcal{F}_{22} - \mathcal{F}_{22}^T & (A_i \mathcal{F}_{22} + B_i W) \Lambda & A_i \mathcal{F}_{22} + B_i W \\ \star & \star & \beta \tilde{Q}_{11i} - \tilde{P}_{11i} & \beta \tilde{Q}_{12i} - \tilde{P}_{12i} \\ \star & \star & \star & \beta \tilde{Q}_{22i} - \tilde{P}_{22i} \\ \star & \star & \star & \star \\ \star & \star & \star & \star \\ \star & \star & \star & \star \\ \star & \star & \star & \star \\ \mathbf{0} & \mathbf{0} & \mathbf{0} & B_m \\ (A_{di} \mathcal{F}_{22} + B_i W_d) \Lambda & A_{di} \mathcal{F}_{22} + B_i W_d & \mathbf{0} & B_{wi} \\ \mathbf{0} & \mathbf{0} & \mathcal{F}_{11}^T C_m^T - \Lambda^T (W^T D_i^T + \mathcal{F}_{22}^T C_i^T) & \mathbf{0} \\ \mathbf{0} & \mathbf{0} & \mathcal{F}_{12}^T C_m^T - (W^T D_i^T + \mathcal{F}_{22}^T C_i^T) & \mathbf{0} \\ -\tilde{Q}_{11i} & -\tilde{Q}_{12i} & -\Lambda^T (W_d^T D_i^T + \mathcal{F}_{22}^T C_{di}^T) & \mathbf{0} \\ \star & -\tilde{Q}_{22i} & -(W_d^T D_i^T + \mathcal{F}_{22}^T C_{di}^T) & \mathbf{0} \\ \star & \star & -\theta \mathbf{I}_p & D_m - D_{wi} \\ \star & \star & \star & -\mu \mathbf{I}_\ell \end{array} \right] < \mathbf{0} \\ & \qquad \qquad \qquad i = 1, \dots, N \end{aligned} \tag{94}$$

then system (1)–(5) is robustly stabilizable by (6) with

$$K = W \mathcal{F}_{22}^{-1} \quad \text{and} \quad K_d = W_d \mathcal{F}_{22}^{-1} \tag{95}$$

providing an \mathcal{H}_∞ guaranteed cost $\gamma = \sqrt{\mu}$ between the output e_k , as defined by (93), and the input signal w_k .

Proof. The proof follows similar steps to those of the proof of the Theorem 4. Once (94) is verified, then the regularity of $\mathcal{F} = \begin{bmatrix} \mathcal{F}_{11} & \mathcal{F}_{12} \\ \mathcal{F}_{22}\Lambda & \mathcal{F}_{22} \end{bmatrix}$ is assured by the block

$$\tilde{P}_i - \mathcal{F} - \mathcal{F}^T = \begin{bmatrix} \tilde{P}_{11i} - \mathcal{F}_{11} - \mathcal{F}_{11}^T & \tilde{P}_{12i} - \mathcal{F}_{12} - \Lambda^T \mathcal{F}_{22}^T \\ \star & \tilde{P}_{22i} - \mathcal{F}_{22} - \mathcal{F}_{22}^T \end{bmatrix} < \mathbf{0}.$$

Thus it is possible to define the congruence transformation \mathcal{T}_H given by (53) with

$$\mathcal{T} = \mathbf{I}_3 \otimes \mathcal{F}^{-T} = \mathbf{I}_3 \otimes \begin{bmatrix} \mathcal{F}_{11} & \mathcal{F}_{12} \\ \mathcal{F}_{22}\Lambda & \mathcal{F}_{22} \end{bmatrix}^{-T}$$

to get $\hat{\Psi}_i = \mathcal{T}_H \Psi_i \mathcal{T}_H^T$. In block (7,7) of $\hat{\Psi}_i$, it always exist a real scalar $\kappa \in]0, 2[$ such that for $\theta \in]0, 1[$, $\kappa(\kappa - 2) = -\theta$. Thus, replacing this block by $\kappa(\kappa - 2)\mathbf{I}_p$, the optimization variables W and W_d by $K\mathcal{F}_{22}$ and $K_d\mathcal{F}_{22}$, respectively, and using the definitions given by (91)–(93) it is possible to verify (36) by *i*) replacing matrices $\hat{A}_i, \hat{A}_{di}, \hat{C}_i, \hat{C}_{di}, B_{wi}$ and D_{wi} by $\hat{A}_i, \hat{A}_{di}, \hat{C}_i, \hat{C}_{di}, \hat{B}_{wi}$ and \hat{D}_{wi} , respectively, given in (93); *ii*) choosing $G = \frac{1}{\kappa}\mathbf{I}_p$ that leads block (7,7) to be rewritten as in (55); *iii*) assuming

$$P_i = \begin{bmatrix} \mathcal{F}_{11} & \mathcal{F}_{12} \\ \mathcal{F}_{22}\Lambda & \mathcal{F}_{22} \end{bmatrix}^{-T} \begin{bmatrix} \tilde{P}_{11i} & \tilde{P}_{12i} \\ \star & \tilde{P}_{22i} \end{bmatrix} \begin{bmatrix} \mathcal{F}_{11} & \mathcal{F}_{12} \\ \mathcal{F}_{22}\Lambda & \mathcal{F}_{22} \end{bmatrix}^{-1}$$

$$Q_i = \begin{bmatrix} \mathcal{F}_{11} & \mathcal{F}_{12} \\ \mathcal{F}_{22}\Lambda & \mathcal{F}_{22} \end{bmatrix}^{-T} \begin{bmatrix} \tilde{Q}_{11i} & \tilde{Q}_{12i} \\ \star & \tilde{Q}_{22i} \end{bmatrix} \begin{bmatrix} \mathcal{F}_{11} & \mathcal{F}_{12} \\ \mathcal{F}_{22}\Lambda & \mathcal{F}_{22} \end{bmatrix}^{-1}$$

and

$$\mathcal{X}_H = \begin{bmatrix} \begin{bmatrix} \mathcal{F}_{11} & \mathcal{F}_{12} \\ \mathcal{F}_{22}\Lambda & \mathcal{F}_{22} \end{bmatrix}^{-1} & \mathbf{0} \\ \mathbf{0} & \mathbf{0} \\ \mathbf{0} & \mathbf{0} \\ \mathbf{0} & \frac{1}{\kappa}\mathbf{I}_p \\ \mathbf{0} & \mathbf{0} \end{bmatrix}$$

which completes the proof. □

An important aspect of Theorem 7 is the choice of $\Lambda \in \mathbb{R}^{n \times n_m}$ in (94). This matrix plays an important role in this optimization problem, once it is used to adjust the dimensions of block (2,1) of \mathcal{F} that allows to use \mathcal{F}_{22} to design both robust state feedback gains K and K_d . This kind choice made *a priori* also appears in some results found on the literature of filtering theory. Another possibility is to use an interactive algorithm to search for a better choice of Λ . This can be done by taking the following steps:

1. **Set** $max_iter \leftarrow$ maximum number of iterations; $j \leftarrow 0$; $\epsilon =$ precision;
2. **Choose** an initial value of $\Lambda_j \leftarrow \Lambda$ such that (94) is feasible.
 - (a) **Set** $\mu_j \leftarrow \mu$; $\Delta\mu \leftarrow \mu_j$; $\mathcal{F}_{22,j} \leftarrow \mathcal{F}_{22}$; $W_j \leftarrow W$; $W_{d,j} \leftarrow W_d$.
3. **While** ($\Delta\mu > \epsilon$) **AND** ($j < max_iter$)

- (a) **Set** $j \leftarrow j + 1$;
- (b) **If** j is odd
 - i. **Solve** (94) with $\mathcal{F}_{22} \leftarrow \mathcal{F}_{22,j}$; $W \leftarrow W_j$; $W_d \leftarrow W_{d,j}$.
 - ii. **Set** $\Lambda \leftarrow \Lambda_j$;
- Else**
 - i. **Solve** (94) with $\Lambda \leftarrow \Lambda_j$.
 - ii. **Set** $\mathcal{F}_{22,j} \leftarrow \mathcal{F}_{22}$; $W_j \leftarrow W$; $W_{d,j} \leftarrow W_d$.
- End_if**
- (c) **Set** $\mu_j \leftarrow \mu$; $\Delta\mu \leftarrow |(\mu_j - \mu_{j-1})|$;
- End_while**
- 4. **Calculate** K and K_d by means of (95);
- 5. **Set** $\mu_* = \mu_j$

Once this is a non-convex algorithm — only steps 3.(b).i are convex — different initial guesses for Λ may lead to different final values for the controllers K and K_d , as well as to the $\gamma = \sqrt{\mu_*}$. To overcome the main drawback of this proposal, two approaches can be stated. The first follows the ideas of Coutinho et al. (2009) by designing an external loop to the closed-loop system proposed in Figure 6. In this sense, it is possible to design a transfer function that can adjust the gain and zeros of the controlled system. The second approach is based on the work of Rodrigues et al. (2009) where a dynamic output feedback controller is proposed. However, in this case the achieved conditions are non-convex and a relaxation algorithm is required. In the example presented in the sequel, Theorem 7 with

$$\Lambda = \begin{bmatrix} \mathbf{I}_{n_m} \\ \mathbf{0}_{n-n_m \times n_m} \end{bmatrix} \tag{96}$$

Example 5. Consider the uncertain discrete-time system with time-varying delay $d_k \in \mathcal{I}[2, 13]$ as given in (1) with uncertain matrices belonging to polytope (2)-(3) with 2 vertices given by

$$A_1 = \begin{bmatrix} 0.6 & 0 \\ 0.35 & 0.7 \end{bmatrix}, \quad A_{d1} = \begin{bmatrix} 0.1 & 0 \\ 0.2 & 0.1 \end{bmatrix}, \quad A_2 = 1.1A_1, \quad A_{d2} = 1.1A_{d1} \tag{97}$$

$$B_{w1} = \begin{bmatrix} 0 \\ 1 \end{bmatrix}, \quad B_1 = \begin{bmatrix} 0 \\ 1 \end{bmatrix}, \quad B_{w2} = 1.1B_{w1}, \quad B_2 = 1.1B_1 \tag{98}$$

$$C_1 = [1 \ 0], \quad C_{d1} = [0 \ 0.05], \quad C_2 = 1.1C_1, \quad C_{d2} = 1.1C_{d1} \tag{99}$$

$$D_{w1} = 0.2, \quad D_1 = 0.1, \quad D_{w2} = 1.1D_{w1}, \quad D_2 = 1.1D_1 \tag{100}$$

It is desired to design robust state feedback gains for control law (6) such that the output of this uncertain system approaches the behavior of delay-free model given by

$$\Omega_m = G(z) = \frac{0.1847z - 0.01617}{z + 0.3} = \left[\begin{array}{c|c} -0.3 & 0.25 \\ \hline -0.2864 & 0.1847 \end{array} \right] \tag{101}$$

Thus, it is desired to minimize the \mathcal{H}_∞ guaranteed cost between signals e_k and w_k identified in Figure 6. The static gain of model (101) was adjusted to match the gain of the controlled system. This procedure is similar to what has been proposed by Coutinho et al. (2009). The choice of the pole and the zero was arbitrary. Obviously, different models result in different value of \mathcal{H}_∞ guaranteed cost.

By applying Theorem 7 to this problem, with Λ given in (96), it has been found an \mathcal{H}_∞ guaranteed cost $\gamma = 0.2383$ achieved with the robust state feedback gains:

$$K = [1.8043 \quad -0.7138] \quad \text{and} \quad K_d = [-0.1546 \quad -0.0422] \quad (102)$$

In case of unknown d_k , Theorem 7 is unfeasible for the considered variation delay interval, i.e., imposing $K_d = \mathbf{0}$. On the other hand, if this interval is narrower, this system can be stabilized with an \mathcal{H}_∞ guaranteed cost using only the current state. So, reducing the value of \bar{d} from $\bar{d} = 13$, it has been found that Theorem 7 is feasible for $d_k \in \mathcal{I}[2, 10]$ with

$$K = [-2.7162 \quad -0.6003] \quad \text{and} \quad K_d = \mathbf{0} \quad (103)$$

and $\gamma = 0.3427$. Just for a comparison, with this same delay interval, if K and K_d are designed, then the \mathcal{H}_∞ guaranteed cost is reduced about 37.8% yielding an attenuation level given by $\gamma = 0.2131$. Thus, it is clear that, whenever the information about the delay is used it is possible to reduce the \mathcal{H}_∞ guaranteed cost. Some numerical simulations have been done considering gains (102), and a disturbance input given by

$$w_k = \begin{cases} 0, & \text{if } k = 0 \text{ or } k \geq 11 \\ 1, & \text{if } 1 \leq k \leq 10 \end{cases} \quad (104)$$

Two conditions were considered: i) $d_k = 13, \forall k \leq 0$ and different values of $\alpha_1 \in [0, 1]$; and ii) $d_k = d \in \mathcal{I}[2, 13]$ with $\alpha_1 = 1$ (i.e., only for the first vertex). The output responses of the controlled system have been performed with $d_k = 13, \forall k \geq 0$. This family of responses and that of the reference model are shown at the top of Figure 7 with solid lines. A red dashed line is used to indicate the desired model response. The absolute value of the error ($|e_k| = |y_k - y_{mk}|$) is shown in solid lines at the bottom of Figure 7 and the estimate \mathcal{H}_∞ guaranteed cost provide by Theorem 7 in dashed red line. The respective control signals are shown in Figure 8.

The other set of time simulations has been performed using only vertex number 1 ($\alpha_1 = 1$). In this numerical experiment, the perturbation (104) has been applied to system defined by vertex 1 and twelve numerical simulations were performed, one for each constant delay value $d_k = d \in [2, 13]$. The results are shown in Figure 9: at the top, a red dashed line indicates the model response and at the bottom it is shown the absolute value of the error ($|e_k| = |y_k - y_{mk}|$) in solid lines and the estimate \mathcal{H}_∞ guaranteed cost provide by Theorem 7 in dashed red line. This value is the same provide in Figure 7, once it is the same design. The respective control signals performed in simulations shown in Figure 9 are shown in Figure 10.

At last, the frequency response considering the input w_k and the output e_k is shown in Figure 11 with a time-invariant delay. For each value of delay in the interval $[2, 13]$ and $\alpha \in [0, 1]$, a frequency sweep has been performed on both open loop and closed-loop systems. The gains used in the closed-loop system are given in (102). It is interesting to note that, once it is desired that y_k approaches y_{mk} , i.e., e_k approaches zero, the gain frequency response of the closed-loop should approaches zero. By Figure 11 the \mathcal{H}_∞ guaranteed cost of the closed-loop system with time invariant delay is about 0.1551, but this value refers to the case of time-invariant delay only. The estimative provided by Theorem 7 is 0.2383 and considers a time varying delay.

6. Final remarks

In this chapter, some sufficient convex conditions for robust stability and stabilization of discrete-time systems with delayed state were presented. The system considered is uncertain with polytopic representation and the conditions were obtained by using parameter dependent Lyapunov-Krasovskii functions. The Finsler's Lemma was used to obtain LMIs

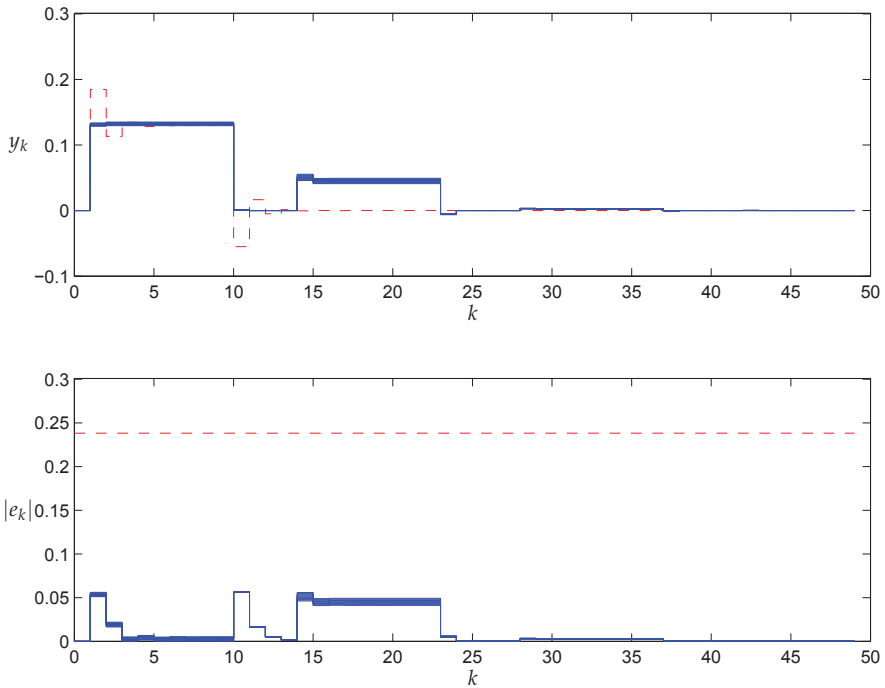

Fig. 7. Time behavior of y_k and $|e_k|$ in blue solid lines and model response (top) and estimated \mathcal{H}_∞ guaranteed cost (bottom) in red dashed lines, for $d_k = 13$ and $\alpha \in [0, 1]$.

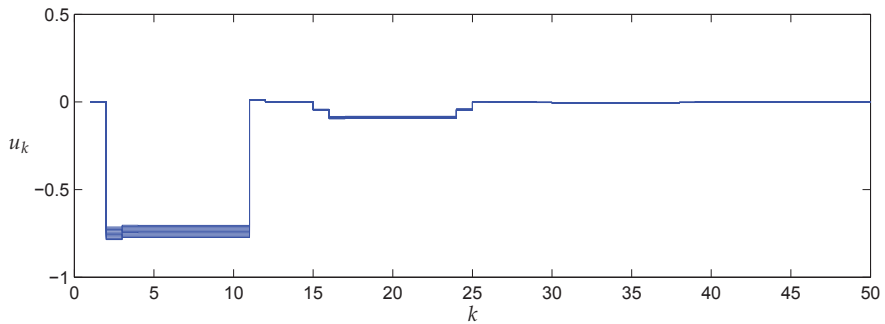

Fig. 8. Control signals used in time simulations presented in Figure 7.

condition where the Lyapunov-Krasovskii variables are decoupled from the matrices of the system. The fundamental problem of robust stability analysis and stabilization has been dealt. The \mathcal{H}_∞ guaranteed cost has been used to improve the performance of the closed-loop system. It is worth to say that even all matrices of the system are affected by polytopic uncertainties, the proposed design conditions are convex, formulated in terms of LMIs.

It is shown how the results on robust stability analysis, synthesis and on \mathcal{H}_∞ guaranteed cost estimation and design can be extended to match some special problems in control theory such

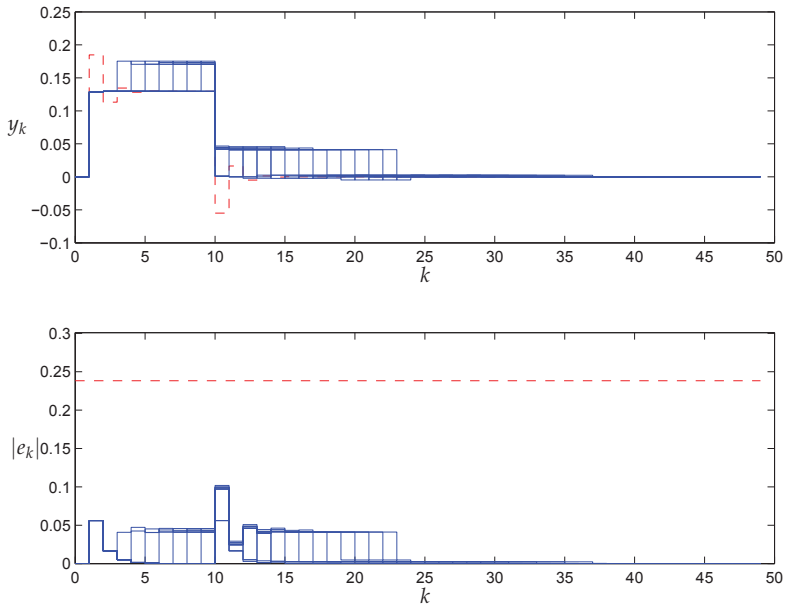

Fig. 9. Time behavior of y_k and $|e_k|$ in blue solid lines and model response (top) and estimated \mathcal{H}_∞ guaranteed cost (bottom) in red dashed lines, for vertex 1 and delays from 2 to 13.

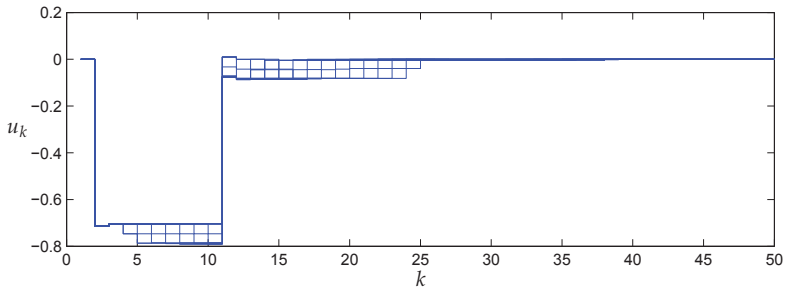

Fig. 10. Control signals used in time simulations presented in Figure 9.

as decentralized control, switched systems, actuator failure, output feedback and following model conditions.

It has been shown that the proposed convex conditions can be systematically obtained by *i*) defining a suitable positive definite parameter dependent Lyapunov-Krasovskii function; *ii*) calculating an over bound for $\Delta V(k) < \mathbf{0}$ and *iii*) applying Finsler's Lemma to get a set of LMIs, formulated in an enlarged space, where cross products between the matrices of the system and the matrices of the Lyapunov-Krasovskii function are avoided. In case of robust design conditions, they are obtained from the respective analysis conditions by congruence transformation and, in the \mathcal{H}_∞ guaranteed cost design, by replacing some matrix blocs by their over bounds. Numerical examples are given to demonstrate some relevant aspects of the proposed conditions.

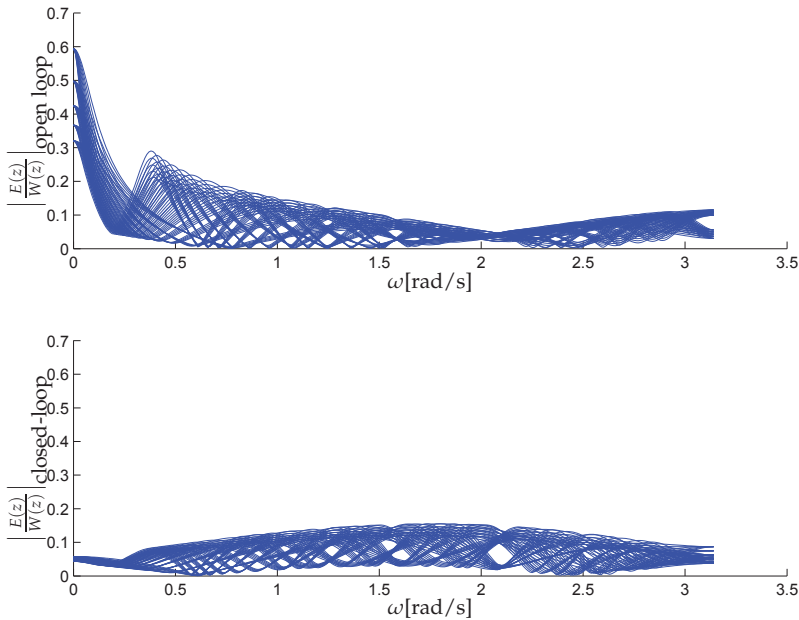

Fig. 11. Gain frequency response between signals e_k and w_k for the open loop (top) and closed-loop (bottom) cases for delays from 2 to 13 and a sweep on $\alpha \in [0, 1]$.

The approach used in this proposal can be used to deal with more complete Lyapunov-Krasovskii functions, yielding less conservative conditions for both robust stability analysis and design, including closed-loop performance specifications as presented in this chapter.

7. References

- Boukas, E.-K. (2006). Discrete-time systems with time-varying time delay: stability and stabilizability, *Mathematical Problems in Engineering* 2006: 1–10.
- Chen, W. H., Guan, Z. H. & Lu, X. (2004). Delay-dependent guaranteed cost control for uncertain discrete-time systems with both state and input delays, *Journal of The Franklin Institute* 341(5): 419–430.
- Chu, J. (1995). Application of a discrete optimal tracking controller to an industrial electric heater with pure delays, *Journal of Process Control* 5(1): 3–8.
- Coutinho, D. F., Pereira, L. F. A. & Yoneyama, T. (2009). Robust \mathcal{H}_2 model matching from frequency domain specifications, *IET Control Theory and Applications* 3(8): 1119–1131.
- de Oliveira, M. C. & Skelton, R. E. (2001). Stability tests for constrained linear systems, in S. O. Reza Moheimani (ed.), *Perspectives in Robust Control*, Vol. 268 of *Lecture Notes in Control and Information Science*, Springer-Verlag, New York, pp. 241–257.
- de Oliveira, P. J., Oliveira, R. C. L. F., Leite, V. J. S., Montagner, V. F. & Peres, P. L. D. (2002). LMI based robust stability conditions for linear uncertain systems: a numerical comparison, *Proceedings of the 41st IEEE Conference on Decision and Control*, Las Vegas, pp. 644–649.

- Du, D., Jiang, B., Shi, P. & Zhou, S. (2007). \mathcal{H}_∞ filtering of discrete-time switched systems with state delays via switched Lyapunov function approach, *IEEE Transactions on Automatic Control* 52(8): 1520–1525.
- Fridman, E. & Shaked, U. (2005a). Delay dependent \mathcal{H}_∞ control of uncertain discrete delay system, *European Journal of Control* 11(1): 29–37.
- Fridman, E. & Shaked, U. (2005b). Stability and guaranteed cost control of uncertain discrete delay system, *International Journal of Control* 78(4): 235–246.
- Gao, H., Lam, J., Wang, C. & Wang, Y. (2004). Delay-dependent robust output feedback stabilisation of discrete-time systems with time-varying state delay, *IEE Proceedings — Control Theory and Applications* 151(6): 691–698.
- Gu, K., Kharitonov, V. L. & Chen, J. (2003). *Stability of Time-delay Systems*, Control Engineering, Birkhäuser, Boston.
- He, Y., Wu, M., Liu, G.-P. & She, J.-H. (2008). Output feedback stabilization for a discrete-time system with a time-varying delay, *IEEE Transactions on Automatic Control* 53(11): 2372–2377.
- Hetel, L., Daafouz, J. & Iung, C. (2008). Equivalence between the Lyapunov-Krasovskii functionals approach for discrete delay systems and that of the stability conditions for switched systems, *Nonlinear Analysis: Hybrid Systems* 2: 697–705.
- Ibrir, S. (2008). Stability and robust stabilization of discrete-time switched systems with time-delays: LMI approach, *Applied Mathematics and Computation* 206: 570–578.
- Kandanvli, V. K. R. & Kar, H. (2009). Robust stability of discrete-time state-delayed systems with saturation nonlinearities: Linear matrix inequality approach, *Signal Processing* 89: 161–173.
- Kapila, V. & Haddad, W. M. (1998). Memoryless \mathcal{H}_∞ controllers for discrete-time systems with time delay, *Automatica* 34(9): 1141–1144.
- Kolmanovskii, V. & Myshkis, A. (1999). *Introduction to the Theory and Applications of Functional Differential Equations*, Mathematics and Its Applications, Kluwer Academic Publishers.
- Leite, V. J. S. & Miranda, M. F. (2008a). Robust stabilization of discrete-time systems with time-varying delay: an LMI approach, *Mathematical Problems in Engineering* pp. 1–15.
- Leite, V. J. S. & Miranda, M. F. (2008b). Stabilization of switched discrete-time systems with time-varying delay, *Proceedings of the 17th IFAC World Congress*, Seoul.
- Leite, V. J. S., Montagner, V. F., de Oliveira, P. J., Oliveira, R. C. L. F., Ramos, D. C. W. & Peres, P. L. D. (2004). Estabilidade robusta de sistemas lineares através de desigualdades matriciais lineares, *SBA Controle & Automação* 15(1).
- Leite, V. J. S. & Peres, P. L. D. (2003). An improved LMI condition for robust \mathcal{D} -stability of uncertain polytopic systems, *IEEE Transactions on Automatic Control* 48(3): 500–504.
- Leite, V. S. J., Tarbouriech, S. & Peres, P. L. D. (2009). Robust \mathcal{H}_∞ state feedback control of discrete-time systems with state delay: an LMI approach, *IMA Journal of Mathematical Control and Information* 26: 357–373.
- Liu, X. G., Martin, R. R., Wu, M. & Tang, M. L. (2006). Delay-dependent robust stabilisation of discrete-time systems with time-varying delay, *IEE Proceedings — Control Theory and Applications* 153(6): 689–702.
- Ma, S., Zhang, C. & Cheng, Z. (2008). Delay-dependent robust \mathcal{H}_∞ control for uncertain discrete-time singular systems with time-delays, *Journal of Computational and Applied Mathematics* 217: 194–211.

- Mao, W.-J. & Chu, J. (2009). \mathcal{D} -stability and \mathcal{D} -stabilization of linear discrete time-delay systems with polytopic uncertainties, *Automatica* 45(3): 842–846.
- Montagner, V. F., Leite, V. J. S., Tarbouriech, S. & Peres, P. L. D. (2005). Stability and stabilizability of discrete-time switched linear systems with state delay, *Proceedings of the 2005 American Control Conference*, Portland, OR.
- Niculescu, S.-I. (2001). *Delay Effects on Stability: A Robust Control Approach*, Vol. 269 of *Lecture Notes in Control and Information Sciences*, Springer-Verlag, London.
- Oliveira, R. C. L. F. & Peres, P. L. D. (2005). Stability of polytopes of matrices via affine parameter-dependent Lyapunov functions: Asymptotically exact LMI conditions, *Linear Algebra and Its Applications* 405: 209–228.
- Phat, V. N. (2005). Robust stability and stabilizability of uncertain linear hybrid systems with state delays, *IEEE Transactions on Circuits and Systems Part II: Analog and Digital Signal Processing* 52(2): 94–98.
- Richard, J.-P. (2003). Time-delay systems: an overview of some recent advances and open problems, *Automatica* 39(10): 1667–1694.
- Rodrigues, L. A., Gonçalves, E. N., Leite, V. J. S. & Palhares, R. M. (2009). Robust reference model control with LMI formulation, *Proceedings of the IASTED International Conference on Identification, Control and Applications*, Honolulu, HI, USA.
- Shi, P., Boukas, E. K., Shi, Y. & Agarwal, R. K. (2003). Optimal guaranteed cost control of uncertain discrete time-delay systems, *Journal of Computational and Applied Mathematics* 157(2): 435–451.
- Silva, L. F. P., Leite, V. J. S., Miranda, M. F. & Nepomuceno, E. G. (2009). Robust \mathcal{D} -stabilization with minimization of the \mathcal{H}_∞ guaranteed cost for uncertain discrete-time systems with multiple delays in the state, *Proceedings of the 49th IEEE Conference on Decision and Control*, IEEE, Atlanta, GA, USA. CD ROM.
- Srinivasagupta, D., Schättler, H. & Joseph, B. (2004). Time-stamped model predictive previous control: an algorithm for previous control of processes with random delays, *Computers & Chemical Engineering* 28(8): 1337–1346.
- Syrmos, C. L., Abdallah, C. T., Dorato, P. & Grigoriadis, K. (1997). Static output feedback — a survey, *Automatica* 33(2): 125–137.
- Xu, J. & Yu, L. (2009). Delay-dependent guaranteed cost control for uncertain 2-D discrete systems with state delay in the FM second model, *Journal of The Franklin Institute* 346(2): 159 – 174.
URL: <http://www.sciencedirect.com/science/article/B6V04-4TM9NGD1/2/85c9f1b946d134a052d36dbe498df5bd>
- Xu, S., Lam, J. & Mao, X. (2007). Delay-dependent \mathcal{H}_∞ control and filtering for uncertain markovian jump systems with time-varying delays, *IEEE Transactions on Circuits and Systems Part I: Fundamental Theory and Applications* 54(9): 2070–2077.
- Yu, J., Xie, G. & Wang, L. (2007). Robust stabilization of discrete-time switched uncertain systems subject to actuator saturation, *Proceedings of the 2007 American Control Conference*, New York, NY, USA, pp. 2109–2112.
- Yu, L. & Gao, F. (2001). Optimal guaranteed cost control of discrete-time uncertain systems with both state and input delays, *Journal of The Franklin Institute* 338(1): 101 – 110.
URL: <http://www.sciencedirect.com/science/article/B6V04-4286KHS-9/2/8197c8472fd444d1396b19619d4dcaf>
- Zhang, H., Xie, L. & Duan, D. G. (2007). \mathcal{H}_∞ control of discrete-time systems with multiple input delays, *IEEE Transactions on Automatic Control* 52(2): 271–283.

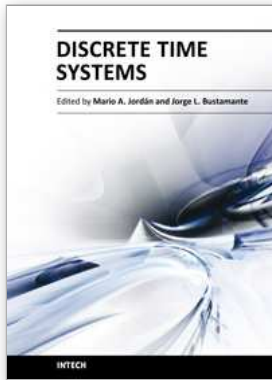

Discrete Time Systems

Edited by Dr. Mario Alberto Jordán

ISBN 978-953-307-200-5

Hard cover, 526 pages

Publisher InTech

Published online 26, April, 2011

Published in print edition April, 2011

Discrete-Time Systems comprehend an important and broad research field. The consolidation of digital-based computational means in the present, pushes a technological tool into the field with a tremendous impact in areas like Control, Signal Processing, Communications, System Modelling and related Applications. This book attempts to give a scope in the wide area of Discrete-Time Systems. Their contents are grouped conveniently in sections according to significant areas, namely Filtering, Fixed and Adaptive Control Systems, Stability Problems and Miscellaneous Applications. We think that the contribution of the book enlarges the field of the Discrete-Time Systems with signification in the present state-of-the-art. Despite the vertiginous advance in the field, we also believe that the topics described here allow us also to look through some main tendencies in the next years in the research area.

How to reference

In order to correctly reference this scholarly work, feel free to copy and paste the following:

Valter J. S. Leite, Michelle F. F. Castro, André F. Caldeira, Márcio F. Miranda and Eduardo N. Gonçalves (2011). Uncertain Discrete-Time Systems with Delayed State: Robust Stabilization with Performance Specification via LMI Formulations, *Discrete Time Systems*, Dr. Mario Alberto Jordán (Ed.), ISBN: 978-953-307-200-5, InTech, Available from: <http://www.intechopen.com/books/discrete-time-systems/uncertain-discrete-time-systems-with-delayed-state-robust-stabilization-with-performance-specificati>

INTECH

open science | open minds

InTech Europe

University Campus STeP Ri
Slavka Krautzeka 83/A
51000 Rijeka, Croatia
Phone: +385 (51) 770 447
Fax: +385 (51) 686 166
www.intechopen.com

InTech China

Unit 405, Office Block, Hotel Equatorial Shanghai
No.65, Yan An Road (West), Shanghai, 200040, China
中国上海市延安西路65号上海国际贵都大饭店办公楼405单元
Phone: +86-21-62489820
Fax: +86-21-62489821

© 2011 The Author(s). Licensee IntechOpen. This chapter is distributed under the terms of the [Creative Commons Attribution-NonCommercial-ShareAlike-3.0 License](#), which permits use, distribution and reproduction for non-commercial purposes, provided the original is properly cited and derivative works building on this content are distributed under the same license.