

A Simple Prediction Model for PCC Voltage Variation Due to Active Power Fluctuation for a Grid Connected Wind Turbine

Sang-Jin Kim and Se-Jin Seong
*Junma Engineering Co., Ltd. Dept. of Electrical Engineering,
Chungnam National University
Korea*

1. Introduction

A great deal of attention is focused on the source of new renewable energy under the present circumstance that serious problems occur all over the industry and the economy due to the high cost of energy according to the high price of oil. For these reasons, wind energy has been installed all over the world and is the fastest growing energy source in the world. In cases of micro grid areas and islands that are isolated from the main power supply and are provided by electric power through diesel engines, the COE(Cost of Energy) is much higher due to shipping expenses of materials for the generation of electric power. It is, therefore, important to have a big interest in a hybrid generation system that makes use of the rich source of wind by connecting wind turbines with the established power system in parallel(Song et al., 2003; Sloopweg & Kling, 2003).

A wind turbine has output characteristics in which the output power follows the cube of the blowing wind speed which is an uncontrollable element apart from other generating sources. This means that the output power of a wind turbine cannot be controlled. When it connects with a weak grid system of a diesel generation system, it can cause potential unstable elements that can bring about various power problems. Thus, it is necessary that the possible problems according to wind speed be predicted and analyzed when a wind turbine is connected with the existing generating source(Jeong et al., 2007). The purpose of this study is, therefore, to examine voltage variation among several power quality problems that appear when wind speed increases; that is, the output increases at the connecting point between wind turbine and diesel generating system.

It takes actual islands as a model to inquire into what elements other than output variation of wind turbine affect voltage variation at the PCC (Point of Common Coupling) at which a wind turbine is connected with the existing power system. This then tries to predict the amount of voltage variation in advance based on rated capacity of wind turbine to be established and short circuit capacity at the connecting point. It is, ultimately, expected that this study would contribute to predicting power quality including voltage variation when the small-sized wind power generating system is installed and operated in domestic islands, cutting down the cost of power production in islands by ensuring security and reliability of carrying out projects, and improving the penetration ratio of new renewable energy source.

2. System modeling

In order to carry out this study, a domestic island was chosen to operate on by building a small-sized electric power network, which was sampled. The electric power network and the connected wind turbine were modeled briefly and the amount of voltage variation through the simulation based on PSCAD/EMTDC was verified. The Sapsido system as a simplified model formed with power impedance and load impedance was suggested and the amount of voltage variation calculated. Also, the elements which affect voltage variation at the Point of Common Coupling (PCC) of wind turbine through actual measurement by comparing three results was confirmed(KEPC, 2005; IEEE 1547, 2003; E-On Netz GMBH, 2006).

2.1 Equivalent iron loss resistance

This paper made a model by simplifying the Sapsido system located in Boryeong, Chungcheongnamdo to develop the model that a small-sized wind turbine is connected to a system. Sapsido is a small island with an area of 3.78km² located in Boryeong, Chungcheongnamdo. The formation of the overall power supply line in Sapsido, which is an isolated system, is shown in Fig. 1 by obtaining data at the spot. The total 4 diesel generators are being operated and supply power in Sapsido has a 900[kW] facility capacity. Electric power produced at a power plant is supplied to every kind of load through transformers and lines within the island, and a 10[kW] wind turbine is installed and connected to a low voltage line on the seashore.

In order to make the Sapsido system as a model, the power supply line at Fig. 1 is simplified as that of Fig. 2 in which a diesel generator, transformer and loads are indicated in the diagram of Fig. 1. Also, Fig. 2 is formed by regarding the point that a 10[kW] wind turbine is connected to a power supply system as PCC (Point of Common Coupling). Load is divided into Load 1, which is the total one at the front of the wind turbine, and Load 2, which is one at the village on the seashore for the simple modeling.

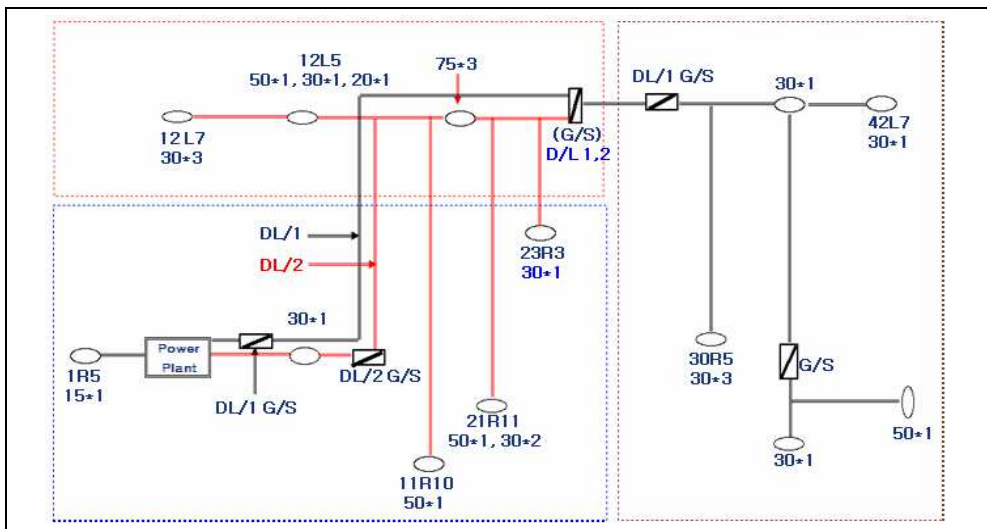

Fig. 1. Power system line diagram in Sapsido

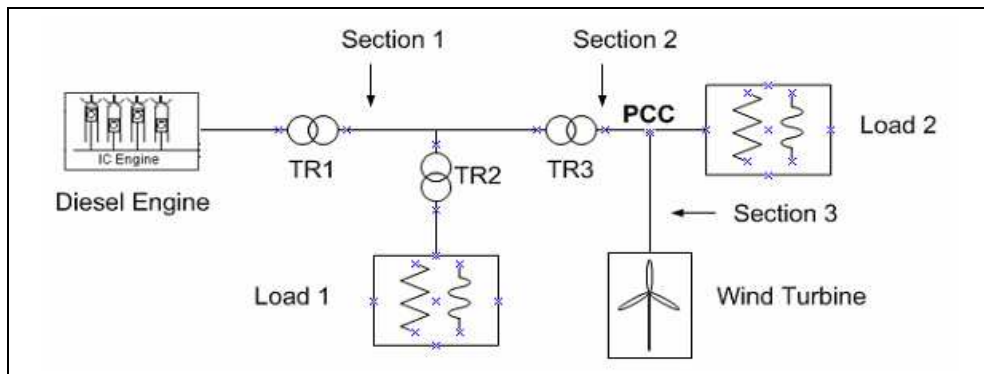

Fig. 2. Outline of power supply system in Sapsido

A more detailed explanation of the components is shown in Table 1. All contents of Table 1, except for the generator, are applied in modeling and only one 300[kVA] generator is modeled for convenience of modeling.

Impedance of the line attains its scale value at the point indicated as the section in Fig. 2, just as indicated in Table 2 according to kinds and length of cable. It applies an almost similar value even though there is little difference according to each manufacturing company.

Classification	Explanation	Reference
Diesel Generator	Sapsido independent generator (4 generators total)	150[kVA] 2set 300[kVA] 2set
TR1	380/6600[V] booster transformer	750[kVA]
TR2	6600/380[V] drop transformer	120[kVA]
TR3	6600/380[V] drop transformer	15[kVA]
Load 1	Load of whole island except for 2 houses in the village on the seashore	Maximum load 120[kW], 50[kVAR]
Load 2	Single phase load of 2houses in the village on the seashore	10[kW], 92~93% power factor
Wind Turbine	BERGEY, BWT-10240	Single phase 10[kW]

Table 1. Power system parameter in Sapsido

Section	Sort	Distance [m]	Scale line Resistance[Ω]
Section 1	ACSR-AW/OC 8[mm ²]	93	0.0484
Section 2	OW 22[mm ²]	93, 139	0.0849, 0.1273
Section 3	OW 22[mm ²]	89	0.0849

Table 2. Data of power supply line in Sapsido

2.2 PSCAD modeling of Sapsido power system full model

This paper developed a simulation model of the power supply system in Sapsido by using PSCAD/EMTDC, and emulated output variation of wind turbine with the model(Rajendiran et al.). A simulation model was made up based on the power supply system in Sapsido in Fig. 2, and the exciter and the governor of diesel generator at a power plant were assumed as ideal ones(Bialasiewicz et al., 1998).

A grid connected inverter that adopts the up-to-date Digital Signal Processor (DSP) takes the role of connecting the output of variable DC voltage of decentralized power from not only a wind turbine but also a solar and fuel cell with the power system containing constant voltage and frequency. If it is presumed that the loss of an inverter operated by PWM switching method is very small and that the AC power that is almost the same as the input DC power will be generated, which will finally reveal output current variation.

Fig. 3 shows the inner structure of the installed grid connected wind turbine system and the simplified equivalent modeling of the grid connected inverter(Kim & Song, 2005). Fig. 4 is designed to generate a current with the same phase as the system voltage by adopting a Phase Locked Loop (PLL) on a grid connected inverter because the power production synchronized with the phase of a power system voltage should be essential in case of grid connection of an AC generating power.

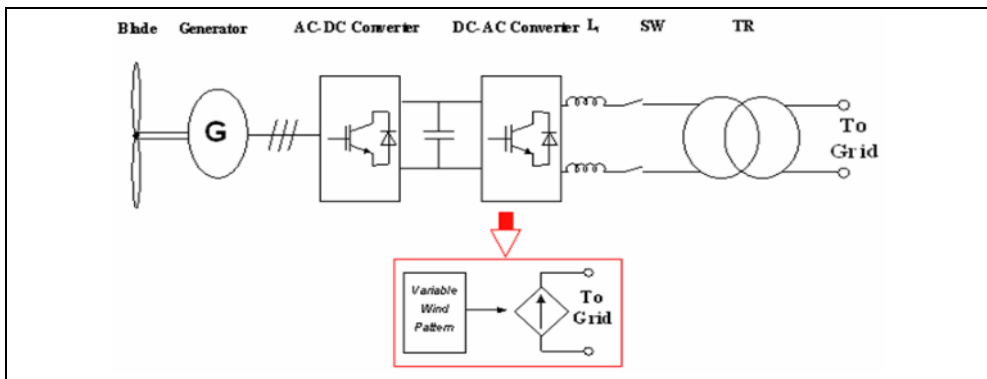

Fig. 3. Wind turbine & Grid connected inverter model

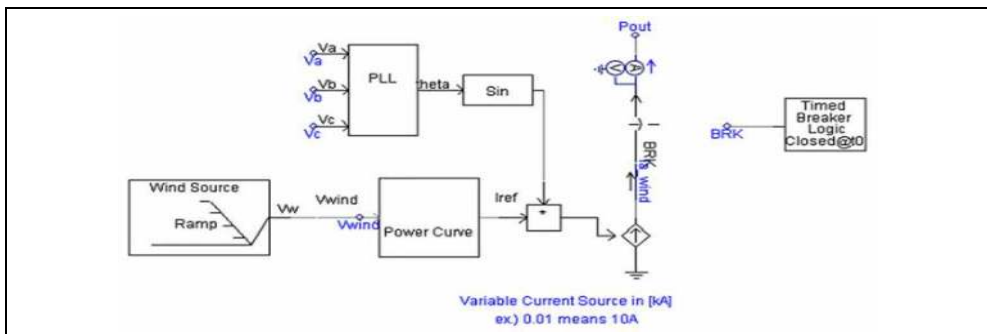

Fig. 4. Simulation model of wind turbine

Fig. 5 is a graph which indicates the variation of power output according to Excel-S wind speed. This paper takes the characteristics of Excel-S which is a 10[kW] model of two models(www.windturbinewarehouse.com).

The simulation model in Fig. 4 takes on a kind of sinusoidal wave current without the modeling of separate equipment for the simplified modeling based on the model of an Excel-S wind turbine. Wind speed input is fixed to generate 10[kW] at 16[m/s] according to the characteristics in Fig. 5.

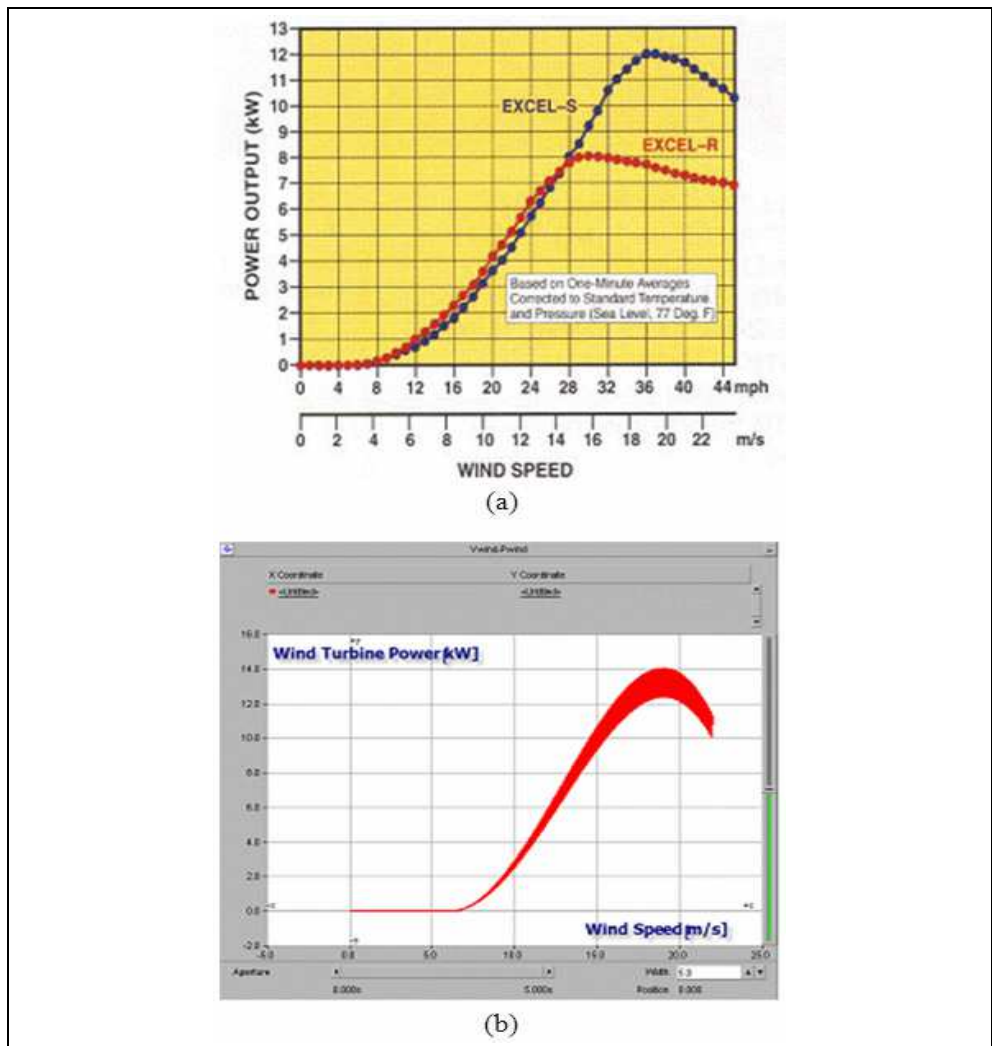

Fig. 5. The compare of characteristic curves

(a) The characteristic curve of wind turbine output

(b) The output characteristics of simulation model of wind turbine

Fig. 5 (b) shows the output characteristics of the simulation model of the developed wind turbine per wind speed. We can see that it accords with the characteristics in Fig. 5 (a). Fig. 6 shows the overall simulation model in Sapsido. All parameters follow to the actual ones, and a grid connected inverter is operating as the control system of output current in proportion to the variation of output power(Sim et al., 2007).

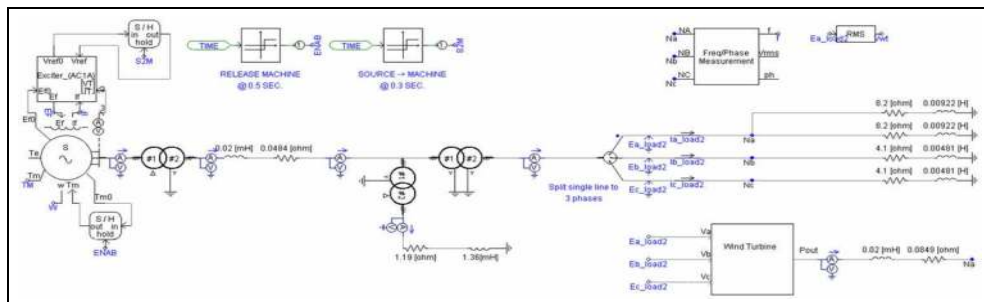

Fig. 6. The simulation formation of power supply system in Sapsido

In simulation, it is observed by emulating the variation of wind speed to investigate the influences in case of grid connected operation from the perspective of voltage variation. If the output of a wind turbine increases under the condition of a constant load, the power plant can reduce as much as the output amount. A graph in Fig. 7 can be gained when the RMS voltage at PCC is observed through the simulation model according to the output of the wind turbine. The output of the wind turbine shows the voltage variation from 6[kW] to about 6-7[V].

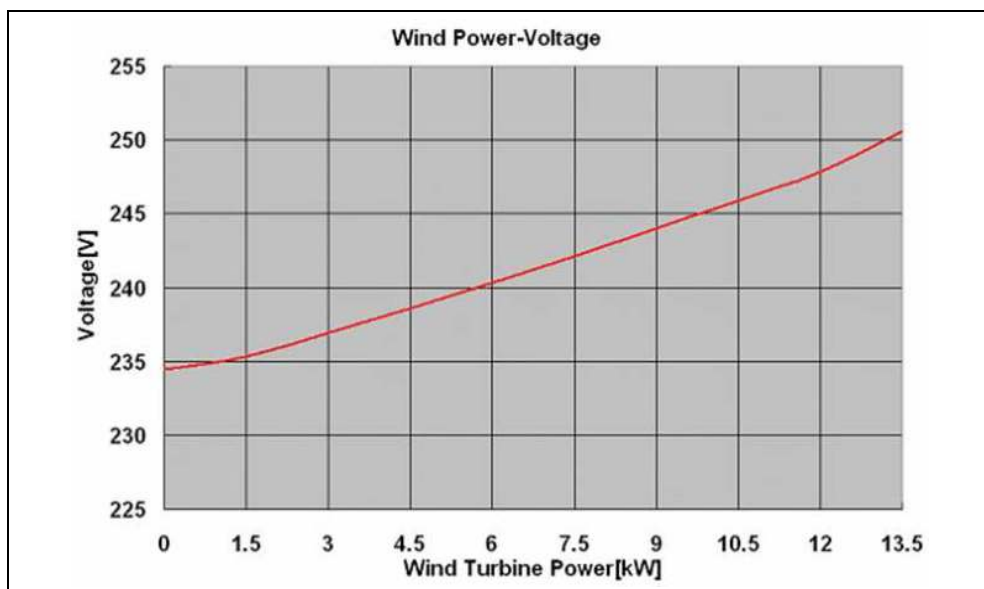

Fig. 7. The simulation of PCC voltage variation in case of wind speed change

2.3 Simplified prediction model for voltage variation study

The overall impedance of the power system in Sapsido can be indicated as shown in Fig. 8 to analyze not the simulation as the above executed, but the actual voltage variation.

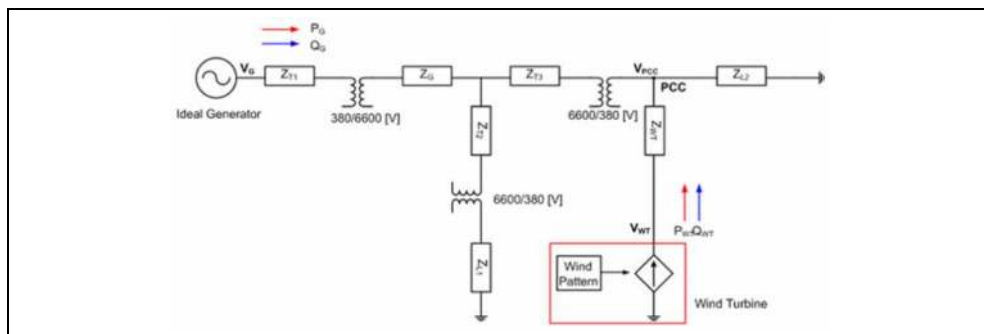

Fig. 8. The overall impedance of Sapsido system

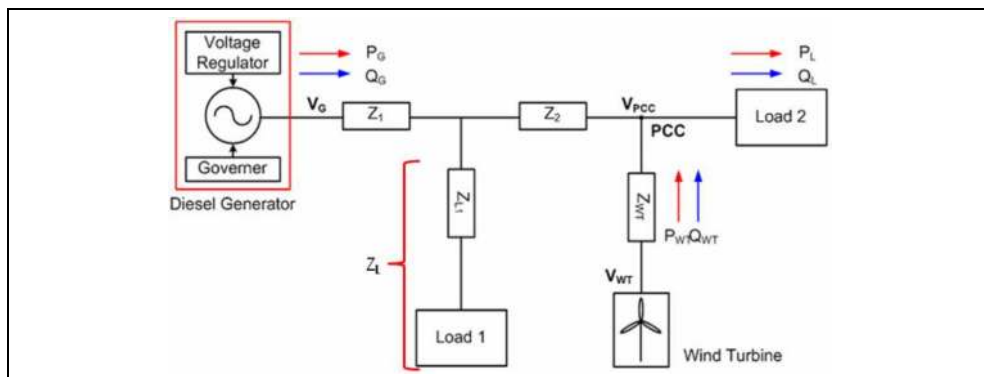

Fig. 9. The simplified impedance formation of power system in Sapsido

System impedance in Sapsido as shown in Fig. 8 can be more simplified as shown in Fig. 9, and indicated as shown in Fig. 10 if the Load1 impedance is much higher than the line impedances Z_1 and Z_2 .

The total equivalent line impedance Z_G can be expressed as (1).

$$Z_G \approx Z_1 + Z_2 \tag{1}$$

In Fig. 10, the equivalent load impedance Z_{LL} includes the line impedance Z_L to the load and the load impedance Z_{Load} as shown in (2). When load current I_L is fixed, output current I_G is changed as shown in (3) if output current I_{WT} of the wind turbine is changed. It can be shown as (4) and (5) if it is indicated in terms of power.

$$Z_L + Z_{Load} = Z_{LL} \tag{2}$$

$$I_G + I_{WT} = I_L \tag{3}$$

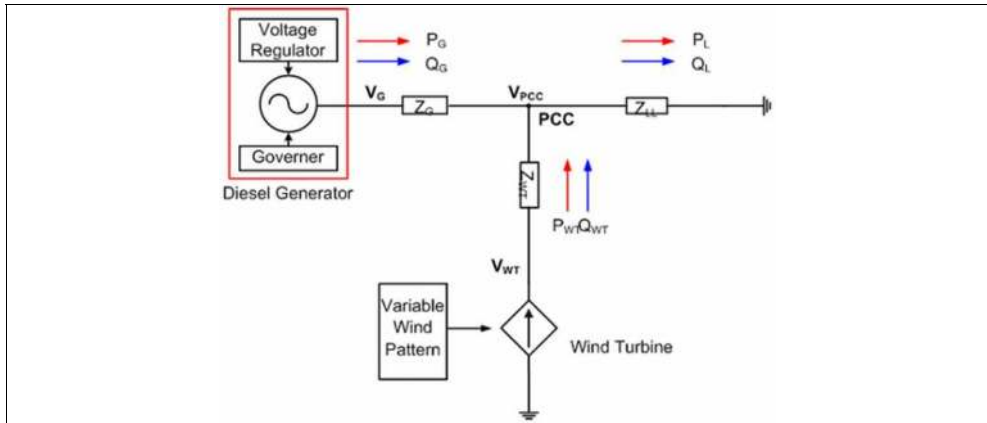

Fig. 10. The simplified model connected with wind turbine

$$P_G + P_{WT} = P_L \tag{4}$$

$$Q_G + Q_{WT} = Q_L \tag{5}$$

The voltage V_{PCC} at the grid connected point can be shown as (6). PCC voltage is composed of the first term by the existing internal voltage source V_G and the second one by current source I_{WT} of the wind turbine from the principle of superposition shown in Fig. 11.

$$V_{PCC} = \left(\frac{Z_{LL}}{Z_{LL} + Z_G} \right) (V_G + Z_G I_{WT}) \tag{6}$$

Fig. 11(a) shows the case that wind turbine is not working ($I_{WT}=0$), and PCC voltage is determined as (7) by impedance distribution between power side and load one. The PCC voltage without wind power generation ($I_{WT}=0$) can be considered as nominal voltage V_{PCC0} in (7). The nominal voltage is determined by source voltage V_G and the impedance distribution. From (6) and (7) the PCC voltage variation, ΔV_{PCC} due to the wind power is proportional to I_{WT} and the equivalent effective impedance Z_{effect} as (8).

These results can also be explained using the principle of superposition in Fig. 11. Z_{effect} corresponds to parallel impedance of Z_G and Z_{LL} as shown in (9). There is one thing to watch out here that line impedance Z_{WT} connected to current source I_{WT} in series does not affect PCC voltage variation; instead, it affects port voltage V_{WT} of the wind turbine according to the change of current I_{WT} as shown in (10).

$$V_{PCC0} = \left(\frac{Z_{LL}}{Z_{LL} + Z_G} \right) V_G \tag{7}$$

$$\Delta V_{PCC} = Z_{effect} \cdot I_{WT} \tag{8}$$

$$Z_{effect} = \frac{Z_{LL} \cdot Z_G}{Z_{LL} + Z_G} \tag{9}$$

$$V_{WT} = V_{PCC} + Z_{WT} \cdot I_{WT} \tag{10}$$

Here,

V_G : output voltage of internal generator

I_{WT} : output current of wind turbine

Z_{Load} : equivalent load impedance

Z_G : equivalent circuit impedance between internal generator and PCC

Z_L : equivalent line impedance between PCC and load

Z_{WT} : line impedance between PCC and wind turbine

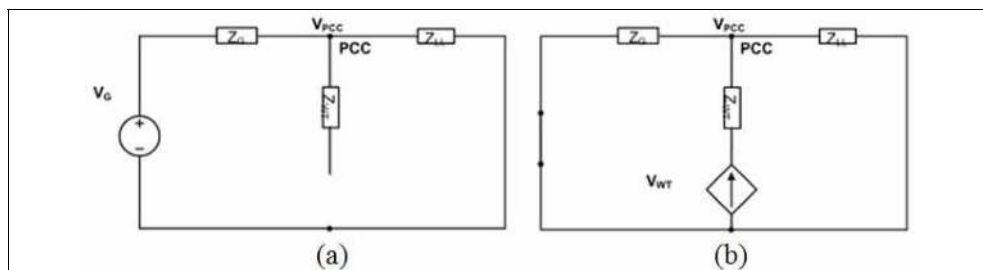

a) The case that wind turbine is not working ($I_{WT}=0$)

b) The analysis of voltage variation port by I_{WT} in case of operating wind turbine

Fig. 11 The analysis of equivalent circuit of the connected model with wind turbine

In order to verify the analysis, the analysis is done by converting impedance in Fig. 8 into the actual impedance parameter such as in Table 3.

Classification	Explanation	Reference
Ideal Generator	Sapsido power plant (3 phase)	380[V]
Z_{T1}	750[kVA] transformer impedance (380[V] scale value)	$0.013 \angle 71.57$
Z_{T2}	120[kVA] transformer impedance (380[V] scale value)	$0.076 \angle 71.57$
Z_{T3}	15[kVA] transformer impedance (380[V] scale value)	$0.611 \angle 71.57$
Z_G	Line impedance of high voltage side (380[V] scale value)	$0.0002 \angle 7.13$
Z_{L1}	Load impedance of whole island except for 2 houses in the village on the seashore	$1.35 \angle 25.73$
Z_{L2}	Load impedance of 2 houses in the village on the seashore	$4.45 \angle 23$
Z_{WT}	Line impedance of wind turbine side	$0.085 \angle 5.05$

Table 3. The actual impedance parameter

The simplified impedance shown in Fig. 10 is indicated in Table 4 below.

Classification	Explanation	Value
Ideal Generator	Sapsido power plant (3 phase)	380[V]
Z_G	Scale line impedance	$0.625 \angle 72.37$
Z_{LL}	Scale load impedance	$4.19 \angle 22.24$
Z_{WT}	Line impedance of wind turbine side	$0.085 \angle 5.05$

Table 4. Scale impedance parameter

$$\therefore Z_{effect} = \frac{Z_{LL} \cdot Z_G}{Z_{LL} + Z_G} = 0.57 \angle 66.4^\circ \tag{11}$$

$$\therefore \Delta V_{pcc} = 0.57 \angle 66.4^\circ \times I_{WT} \tag{12}$$

The final equation on voltage variation occurring at the actual PCC with data in Table 4 is shown in (11) and (12).

2.4 The actual measurement

Data is measured by installing a power measuring instrument at the PCC step within the actual system in Sapsido to enhance reliability in this study. Fig. 12 shows the location where measurement is carried out. Valid/invalid power graph of the wind turbine according to time based on this measured data is shown in Fig. 13.

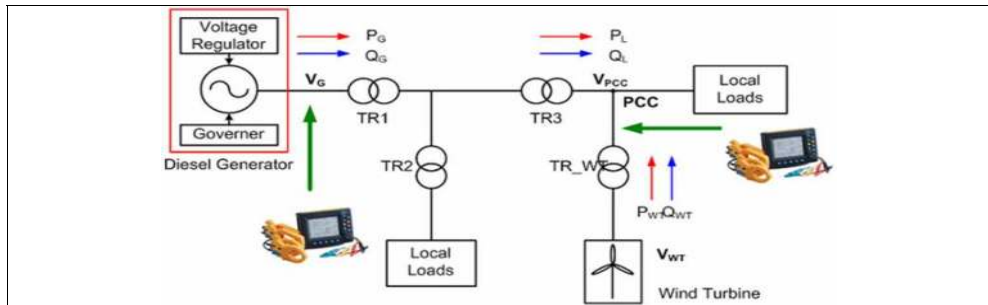

Fig. 12. Measuring location of power in Sapsido

Fig. 14 shows voltage variation amount for the output. The measured dots show the tendency of increase proportional to the power output and are represented as a solid line. Dots inside the circle, near zero output power, show the voltage variation in normal operating conditions at the PCC even without wind power generation. An approximate 7[V] voltage variation is shown in case of producing about 5.5[kW].

Table 5 shows the comparative results of the voltage variation using two simulation models and one experimental measurement.

At first, the voltage variation of 6.4V results from the PSCAD simulation model which has full modeling of the wind turbine and complex line impedance parameters. The second result of 6.5V comes from the proposed simplified prediction model of PCC voltage using (8). The last result of 6.9V PCC voltage deviation is a measured value as shown in Fig. 14 during the field test.

From this comparison the result of the proposed prediction model highly matches the simulation and measurement results.

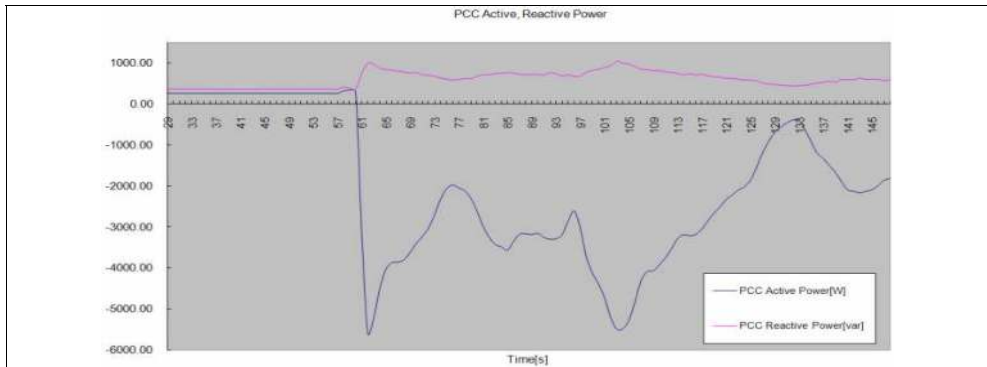

Fig. 13. PCC valid· invalid power in case of wind speed change

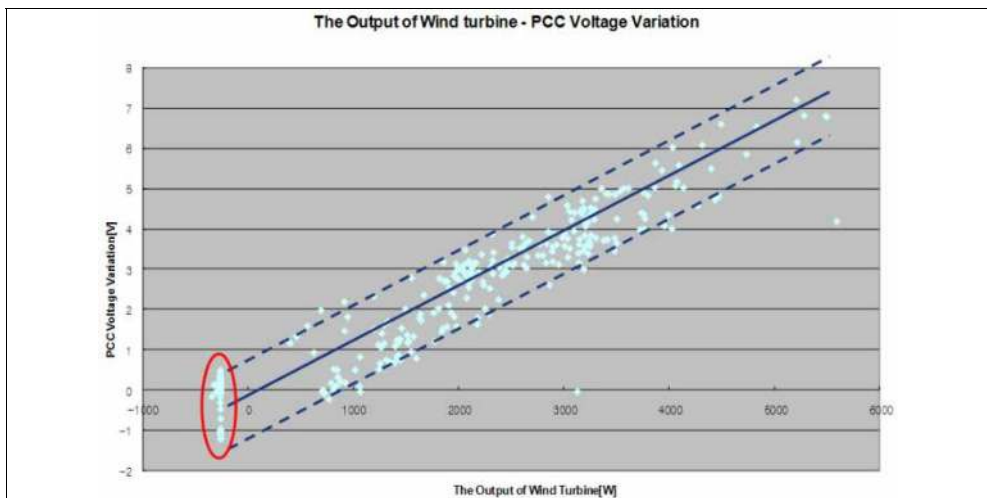

Fig. 14. Measured value of PCC voltage variation amount for the output of wind turbine

Classification	Amount of voltage variation in case of 5.5[kW] generation (V)
PSCAD Model	6.4
Simplified prediction model	6.5
Results of actual measurement	6.9

Table 5. The comparative table of PCC voltage variation amount in case of active power fluctuation of wind turbine

3. Conclusion

This study analyzed voltage variation according to the active power fluctuation of a wind turbine connected with the existing generating facilities in parallel in a small-sized isolated system, e.g. an island. The prediction of the voltage variation amount at the connected point is possible under the consideration of the change of installation location of a wind turbine and load fluctuation in the future. The variations of voltage drop happen according to the fluctuation of generated wind amount, and voltage change (rising) in receptive value inevitably. The simulation model was developed by using PSCAD/EMTDC to analyze voltage variation of the simplified model in the small-sized isolated system; and suggested the method to analytically obtain voltage variation amount through the analysis of a lot more generalized equivalent circuit. It was confirmed that the suggested method, simulation and the results of actual measurement matched in the error range of about less than 7%. It is considered that the study on the additional control method of a wind turbine to make the penetration ratio of wind plant increase in comparison to load capacity is necessary along with the development of a much more precise simulation model by taking account of the uniqueness of the excessive condition of generators in the future.

4. References

- Bialasiewicz, J; Muljadi, E. & Drouilhet, S. & Nix, G. (1998) Modular Simulation of a Hybrid Power System with Diesel and Wind Turbine Generation, Windpower '98 Bakersfield, CA
- E-ON Netz GmbH, (2006) *Grid Code-High and Extra High Voltage*
- IEEE 1547 (2003) *IEEE Standard for Interconnecting Distributed Resources with Electric Power Systems*
- Jeong, W.; Yoon, K. & Kim, S. & Lee, H. (2007) The analysis of voltage variation according to grid connection at wind plant in Yangyang, *International Spring Academy Conference of Korea Wind Energy, papers*, 35-40
- Kim, J. & Song, H. (2005) The development of PSCAD/EMTDC simulation model of variable speed wind plant system by permanent magnet synchronous generator, *Society of Power & Electronics, papers*, 610-617
- Korea Electric Power Corporation (2005) *Technology standard connected with the distributed power supply system*
- Rajendiran, K.; Keerthipala, W. & Nayar, C. PSCAD/EMTDC Based Simulation of a Wind-Diesel Conversion Scheme
- Sim, M.; Palle, B. & Chakraborty, S. & Uriarte, C. (2007) *Electrical Model Development and Validation for Distributed Resources*, Subcontract Report, NREL
- Slootweg, J. & Kling, W. (2003) Is the Answer Blowing in the Wind?, *IEEE Power & Energy Magazine*, No., 6, 26-33
- Song, S.; Kim, I. & Han, B. (2003) Electric characteristics of wind turbine and interaction in case of grid connection, *Power & Electronics Magazine, Ed., Vol., 8, No., 6*, 21-27
- www.windturbinewarehouse.com/pdgs/bergey/BergeyExcel-S 10kW Turbine Specs.03.pdf

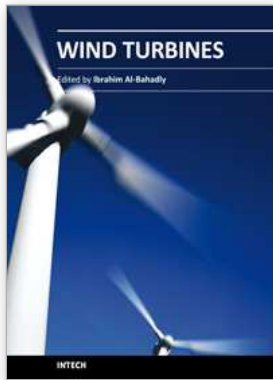

Wind Turbines

Edited by Dr. Ibrahim Al-Bahadly

ISBN 978-953-307-221-0

Hard cover, 652 pages

Publisher InTech

Published online 04, April, 2011

Published in print edition April, 2011

The area of wind energy is a rapidly evolving field and an intensive research and development has taken place in the last few years. Therefore, this book aims to provide an up-to-date comprehensive overview of the current status in the field to the research community. The research works presented in this book are divided into three main groups. The first group deals with the different types and design of the wind mills aiming for efficient, reliable and cost effective solutions. The second group deals with works tackling the use of different types of generators for wind energy. The third group is focusing on improvement in the area of control. Each chapter of the book offers detailed information on the related area of its research with the main objectives of the works carried out as well as providing a comprehensive list of references which should provide a rich platform of research to the field.

How to reference

In order to correctly reference this scholarly work, feel free to copy and paste the following:

Sang-Jin Kim and Se-Jin Seong (2011). A Simple Prediction Model for PCC Voltage Variation Due to Active Power Fluctuation for a Grid Connected Wind Turbine, Wind Turbines, Dr. Ibrahim Al-Bahadly (Ed.), ISBN: 978-953-307-221-0, InTech, Available from: <http://www.intechopen.com/books/wind-turbines/a-simple-prediction-model-for-pcc-voltage-variation-due-to-active-power-fluctuation-for-a-grid-conne>

INTECH

open science | open minds

InTech Europe

University Campus STeP Ri
Slavka Krautzeka 83/A
51000 Rijeka, Croatia
Phone: +385 (51) 770 447
Fax: +385 (51) 686 166
www.intechopen.com

InTech China

Unit 405, Office Block, Hotel Equatorial Shanghai
No.65, Yan An Road (West), Shanghai, 200040, China
中国上海市延安西路65号上海国际贵都大饭店办公楼405单元
Phone: +86-21-62489820
Fax: +86-21-62489821

© 2011 The Author(s). Licensee IntechOpen. This chapter is distributed under the terms of the [Creative Commons Attribution-NonCommercial-ShareAlike-3.0 License](#), which permits use, distribution and reproduction for non-commercial purposes, provided the original is properly cited and derivative works building on this content are distributed under the same license.