

Magnitude Optimum Techniques for PID Controllers

Damir Vrančić
*Jožef Stefan Institute
Slovenia*

1. Introduction

Today, most tuning rules for PID controllers are based either on the process step response or else on relay-excitation experiments. Tuning methods based on the process step response are usually based on the estimated process gain and process lag and rise times (Åström & Hägglund, 1995). The relay-excitation method is keeping the process in the closed-loop configuration during experiment by using the on/off (relay) controller. The measured data is the amplitude of input and output signals and the oscillation period.

The experiments mentioned are popular in practice due to their simplicity. Namely, it is easy to perform them and get the required data either from manual or from automatic experiments on the process. However, the reduction of process time-response measurement into two or three parameters may lead to improperly tuned controller parameters.

Therefore, more sophisticated tuning approaches have been suggested. They are usually based on more demanding process identification methods (Åström et al., 1998; Gorez, 1997; Huba, 2006). One such method is a magnitude optimum method (MO) (Whiteley, 1946). The MO method results in a very good closed-loop response for a large class of process models frequently encountered in the process and chemical industries (Vrančić, 1995; Vrančić et al., 1999). However, the method is very demanding since it requires a reliable estimation of quite a large number of process parameters, even for relatively simple controller structures (like a PID controller). This is one of the main reasons why the method is not frequently used in practice.

Recently, the applicability of the MO method has been improved by using the concept of 'moments', which originated in identification theory (Ba Hli, 1954; Strejc, 1960; Rake, 1987). In particular, the process can be parameterised by subsequent (multiple) integrals of its input and output time-responses. Instead of using an explicit process model, the new tuning method employs the mentioned multiple integrals for the calculation of the PID controller parameters and is, therefore, called the "Magnitude Optimum Multiple Integration" (MOMI) tuning method (Vrančić, 1995; Vrančić et al., 1999). The proposed approach therefore uses information from a relatively simple experiment in a time-domain while retaining all the advantages of the MO method.

The deficiency of the MO (and consequently of the MOMI) tuning method is that it is designed for optimising tracking performance. This can lead to the poor attenuation of load disturbances (Åström & Hägglund, 1995). Disturbance rejection performance is particularly

decreased for lower-order processes. This is one of the most serious disadvantages of the MO method, since in process control disturbance rejection performance is often more important than tracking performance.

The mentioned deficiency has been recently solved by modifying the original MO criteria (Vrančić et al., 2004b; Vrančić et al., 2010). The modified criteria successfully optimised the disturbance rejection response instead of the tracking response. Hence, the concept of moments (multiple integrations) has been applied to the modified MO criteria as well, and the new tuning method has been called the “Disturbance Rejection Magnitude Optimum” (DRMO) method (Vrančić et al., 2004b; Vrančić et al., 2010).

The MOMI and DRMO tuning methods are not only limited to the self-regulating processes. They can also be applied to integrating processes (Vrančić, 2008) and to unstable processes (Vrančić & Huba, 2011). The methods can also be applied to different controller structures, such as Smith predictors (Vrečko et al., 2001) and multivariable controllers (Vrančić et al., 2001b). However, due to the limited space and scope of this book, they will not be considered further.

2. System description

A stable process may be described by the following process transfer function:

$$G_P(s) = K_{PR} \frac{1 + b_1s + b_2s^2 + \dots + b_ms^m}{1 + a_1s + a_2s^2 + \dots + a_ns^n} e^{-sT_{delay}}, \quad (1)$$

where K_{PR} denotes the process steady-state gain, and a_1 to a_n and b_1 to b_m are the corresponding parameters ($m \leq n$) of the process transfer function, whereby n can be an arbitrary positive integer value and T_{delay} represents the process pure time delay. Note that the denominator in (1) contains only stable poles.

The PID controller is defined as follows:

$$U(s) = G_R(s)R(s) - G_C(s)Y(s), \quad (2)$$

where U , R and Y denote the Laplace transforms of the controller output, the reference and the process output, respectively. The transfer functions $G_R(s)$ and $G_C(s)$ are the feed-forward and the feedback controller paths, respectively:

$$\begin{aligned} G_R(s) &= \frac{K_I + bK_Ps + cK_Ds^2}{s(1 + sT_F)} \\ G_C(s) &= \frac{K_I + K_Ps + K_Ds^2}{s(1 + sT_F)} \end{aligned} \quad (3)$$

The PID controller parameters are proportional gain K_P , integral gain K_I , derivative gain K_D , filter time constant T_F , proportional reference weighting factor b and derivative reference weighting factor c (Åström & Häggglund, 1995). Note that the first-order filter is applied to all three controller terms instead of only the D term in order to reduce noise amplitude at the controller output and to simplify the derivation of the PID controller parameters. The range of parameters b and c is usually between 0 and 1. Since the feed-

forward and the feedback paths are generally different, the PID controller (2) is a two-degrees-of-freedom (2-DOF) controller. Note that controller (2) becomes a 1-DOF controller when choosing $b=c=1$.

The PID controller in a closed-loop configuration with the process is shown in Figure 1.

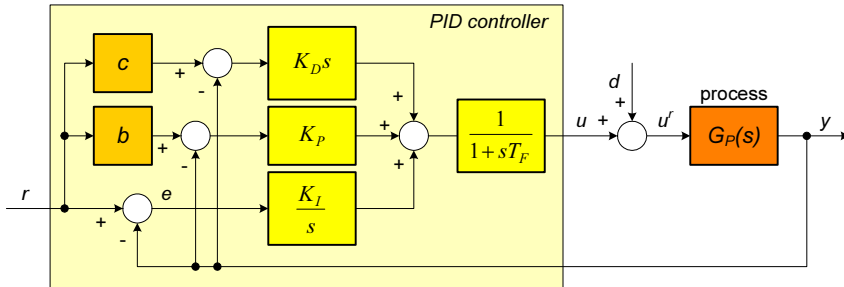

Fig. 1. The closed-loop system with the PID controller

Signals e , d and u^r denote the control error, disturbance and process input, respectively. The closed-loop transfer function with the PID controller is defined as follows:

$$G_{CL}(s) = \frac{Y(s)}{R(s)} = \frac{G_R(s)G_P(s)}{1 + G_C(s)G_P(s)}. \tag{4}$$

For the 1-DOF PID controller ($b=c=1$), the closed-loop transfer function becomes:

$$G_{CL}(s) = \frac{Y(s)}{R(s)} = \frac{G_C(s)G_P(s)}{1 + G_C(s)G_P(s)}. \tag{5}$$

The deficiency of 1-DOF controllers is that they usually cannot achieve optimal tracking and disturbance rejection performance simultaneously. 2-DOF controllers may achieve better overall performance by keeping the optimal disturbance rejection performance while improving tracking performance.

3. Magnitude Optimum (MO) criteria

One possible means of control system design is to ensure that the process output (y) follows the reference (r). The ideal case is that of perfect tracking without delay ($y=r$). In the frequency domain, the closed-loop system should have an infinite bandwidth and zero phase shift. However, this is not possible in practice, since every system features some time delay and dynamics while the controller gain is limited due to physical restrictions.

The new design objective would be to maintain the closed-loop magnitude (amplitude) frequency response (G_{CL}) from the reference to the process output as flat and as close to unity as possible for a large bandwidth (see Figure 2) (Whiteley, 1946; Hanus, 1975; Åström & Hägglund, 1995; Umland & Safiuddin, 1990). Therefore, the idea is to find a controller that makes the frequency response of the closed-loop amplitude as close as possible to unity for lower frequencies.

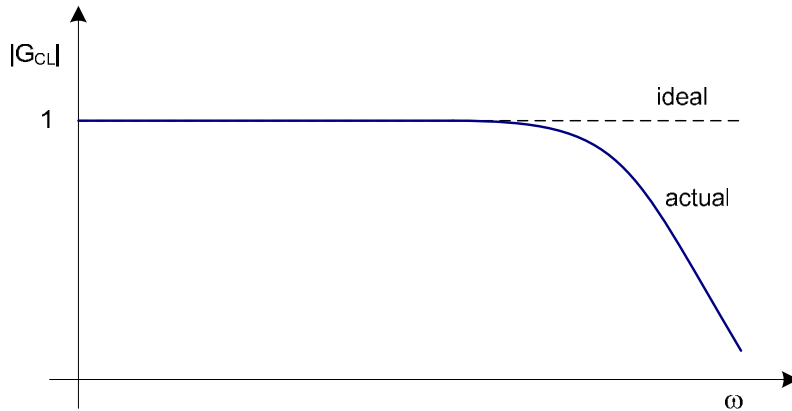

Fig. 2. The amplitude (magnitude) frequency response of the closed-loop system

These requirements can be expressed in the following way:

$$G_{CL}(0) = 1, \quad (6)$$

$$\left. \frac{d^{2k} |G_{CL}(j\omega)|^2}{d\omega^{2k}} \right|_{\omega=0} = 0; \quad k = 1, 2, \dots, k_{\max} \quad (7)$$

for as many k as possible (Åström & Hägglund, 1995).

This technique is called “Magnitude Optimum” (MO) (Umland & Safiuddin, 1990), “Modulus Optimum” (Åström & Hägglund, 1995), or “Betragsoptimum” (Åström & Hägglund, 1995; Kessler, 1955), and it results in a fast and non-oscillatory closed-loop time response for a large class of process models.

If the closed-loop transfer function is described by the following equation:

$$G_{CL}(s) = \frac{f_0 + f_1s + f_2s^2 + \dots}{e_0 + e_1s + e_2s^2 + \dots}, \quad (8)$$

then expression (7) can be met by satisfying the following conditions (Vrančić et al., 2010):

$$\sum_{i=0}^{2n} (-1)^{i+n} (f_i f_{2n-i} e_0^2 - e_i e_{2n-i} f_0^2) = 0; \quad n = 1, 2, \dots \tag{9}$$

Before calculating the parameters of the 1-DOF PID controller, according to the given MO criteria, the pure time delay in expression (1) has to be developed into an infinite Taylor series:

$$e^{-sT_{delay}} = 1 - sT_{delay} + \frac{(sT_{delay})^2}{2!} - \frac{(sT_{delay})^3}{3!} + \dots + \frac{(-1)^k (sT_{delay})^k}{k!} + \dots \tag{10}$$

or Padé series:

$$e^{-sT_{delay}} = \lim_{n \rightarrow \infty} \left(\frac{1 - \frac{sT_{delay}}{2n}}{1 + \frac{sT_{delay}}{2n}} \right)^n = \frac{1 - \frac{sT_{delay}}{2} + \frac{s^2 T_{delay}^2}{2^2 2!} - \dots + (-1)^k \frac{s^k T_{delay}^k}{2^k k!} + \dots}{1 + \frac{sT_{delay}}{2} + \frac{s^2 T_{delay}^2}{2^2 2!} + \dots + \frac{s^k T_{delay}^k}{2^k k!} + \dots} \tag{11}$$

Then, the closed-loop transfer function (5) is calculated from expressions (1), (3) and (10) or else (11). The closed-loop parameters e_i and f_i can be obtained by comparing expressions (8) and (5). The PID controller parameters are then obtained by solving the first three equations ($n=1, 2$ and 3) in expression (9) (Vrančić et al., 1999):

$$K_P = f_1(K_{PR}, a_1, a_2, \dots, a_5, b_1, b_2, \dots, b_5, T_{delay}, T_F) \tag{12}$$

$$K_I = f_2(K_{PR}, a_1, a_2, \dots, a_5, b_1, b_2, \dots, b_5, T_{delay}, T_F) \tag{13}$$

$$K_D = f_3(K_{PR}, a_1, a_2, \dots, a_5, b_1, b_2, \dots, b_5, T_{delay}, T_F) \tag{14}$$

The expressions (12)-(14) are not explicitly given herein, since they would cover several pages. In order to calculate the three PID controller parameters – according to the given MO tuning criteria – *only* the parameters K_{PR} , a_1 , a_2 , a_3 , a_4 , a_5 , b_1 , b_2 , b_3 , b_4 , b_5 , and T_{delay} of the process transfer function (1) are required, even though the process transfer function can be of a higher-order. However, accurately estimating such a high number of process parameters from real measurements could be very problematic. Moreover, if one identifies the fifth-order process model from the actually higher-than-fifth-order process, a systematic error in the estimated process parameters would be obtained, therefore leading to the calculation of non-optimal controller parameters. Accordingly, the accuracy of the estimated process parameters in practice remains questionable.

Note that the actual expressions (12)-(14) remain exactly the same when the process with pure time-delay is developed into a Taylor (10) or Padé (11) series (Vrančić et al., 1999).

4. Magnitude Optimum Multiple Integration (MOMI) tuning method

The problems with original MO tuning method just mentioned can be avoided by using the concept of ‘moments’, known from identification theory (Ba Hli, 1954; Preuss, 1991).

Namely, the process transfer function (1) can be developed into an infinite Taylor series around $s=0$, as follows:

$$G_P(s) = A_0 - A_1s + A_2s^2 - A_3s^3 + \dots, \quad (15)$$

where parameters A_i ($i=0, 1, 2, \dots$) represent time-weighted integrals of the process impulse response $h(t)$ (Ba Hli, 1954; Preuss, 1991; Åström & Hägglund, 1995):

$$A_k = \frac{1}{k!} \int_0^{\infty} t^k h(t) dt. \quad (16)$$

However, the process impulse response cannot be obtained easily in practice since - due to several restrictions - we cannot apply an infinite impulse signal to the process input. Fortunately, the moments A_i can also be obtained by calculating repetitive (multiple) integrals of the process input (u) and output (y) signals during the change of the process steady-state (Strejc, 1960; Vrančić et al., 1999; Vrančić, 2008):

$$\begin{aligned} u_0(t) &= \frac{u(t) - u(0)}{u(\infty) - u(0)} & y_0(t) &= \frac{y(t) - y(0)}{u(\infty) - u(0)} \\ I_{U1}(t) &= \int_0^t u_0(\tau) d\tau & I_{Y1}(t) &= \int_0^t y_0(\tau) d\tau \\ I_{U2}(t) &= \int_0^t I_{U1}(\tau) d\tau & I_{Y2}(t) &= \int_0^t I_{Y1}(\tau) d\tau \\ &\vdots & &\vdots \end{aligned} \quad (17)$$

The moments (integrals, areas) can be calculated as follows:

$$\begin{aligned} A_0 &= y_0(\infty) ; y_1 = A_0 I_{U1}(t) - I_{Y1}(t) \\ A_1 &= y_1(\infty) ; y_2 = A_1 I_{U1}(t) - A_0 I_{U2}(t) + I_{Y2}(t) \\ A_2 &= y_2(\infty) ; y_3 = A_2 I_{U1}(t) - A_1 I_{U2}(t) + A_0 I_{U3}(t) - I_{Y3}(t) \\ &\vdots \end{aligned} \quad (18)$$

It is assumed that:

$$\dot{y}(0) = \ddot{y}(0) = \dddot{y}(0) = \dots = 0. \quad (19)$$

Given that in practice the integration horizon should be limited, there is no need to wait until $t=\infty$. It is enough to integrate until the transient of $y_0(t)$ in (17) dies out. Note that the first impulse (A_0) equals the steady-state process gain, K_{PR} .

In order to clarify the mathematical derivation, a graphical representation of the first moment (area) is shown in Figure 3. Note that u_0 and y_0 represent scaled process input and process output time responses, respectively.

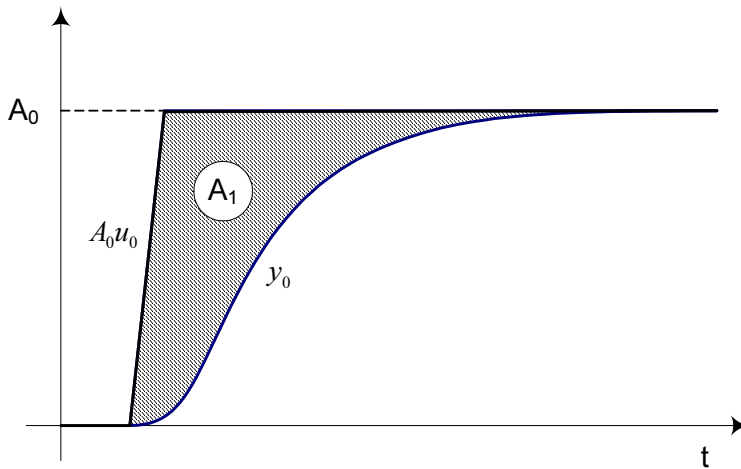

Fig. 3. Graphical representation of the moment (area) A_1 measured from the process steady-state change time response (see shadowed area).

Therefore, in practice the process can be easily parameterised by the moments A_i from the process step-response or else from any other change of the process steady-state. On the other hand, the moments can also be obtained directly from the process transfer function (1), as follows (Vrančić et al., 1999; Vrančić et al., 2001a):

$$\begin{aligned}
 A_0 &= K_{PR} \\
 A_1 &= K_{PR} (a_1 - b_1 + T_{delay}) \\
 A_2 &= K_{PR} \left[b_2 - a_2 - T_{delay} b_1 + \frac{T_{delay}^2}{2!} \right] + A_1 a_1 \\
 &\quad \vdots \\
 A_k &= K_{PR} \left((-1)^{k+1} (a_k - b_k) + \sum_{i=1}^k (-1)^{k+i} \frac{T_{delay}^i b_{k-i}}{i!} \right) + \\
 &\quad + \sum_{i=1}^{k-1} (-1)^{k+i-1} A_i a_{k-i}
 \end{aligned} \tag{20}$$

Let us now calculate the 1-DOF PID controller parameters by using the process transfer function parameterised by moments (15). In order to simplify derivation of the PID controller parameters, the filter within the PID controller (3) is considered to be a part of the process (1):

$$G_p^*(s) = \frac{G_p(s)}{1 + sT_F} \tag{21}$$

Therefore, $G_C(s)$ (3) simplifies into the “schoolbook” PID controller without a filter:

$$G_C^*(s) = (K_I + K_P s + K_D s^2) / s. \quad (22)$$

Since a filter is considered as a part of the process, the measured moments (18) should be changed accordingly. One solution to calculate any new moments is to filter the process output signal:

$$Y_F(s) = \frac{Y(s)}{1 + sT_F} \quad (23)$$

and use signal $y_F(t)$ instead of $y(t)$ in expression (17). However, a much simpler solution is to recalculate the moments as follows:

$$\begin{aligned} A_0^* &= A_0 \\ A_1^* &= A_1 + A_0 T_F \\ A_2^* &= A_2 + A_1 T_F + A_0 T_F^2 \\ &\vdots \end{aligned} \quad (24)$$

where A_i^* denote the moments of the process with included the filter (21).

The parameters e_i and f_i in expression (8) can be obtained by placing expressions (22) and (15) (by replacing moments A_i with A_i^*) into (5). By solving the first three equations in (9), the following PID controller parameters are obtained (Vrančić et al., 2001a):

$$\begin{bmatrix} K_I \\ K_P \\ K_D \end{bmatrix} = \begin{bmatrix} -A_1^* & A_0^* & 0 \\ -A_3^* & A_2^* & -A_1^* \\ -A_5^* & A_4^* & -A_3^* \end{bmatrix}^{-1} \begin{bmatrix} -0.5 \\ 0 \\ 0 \end{bmatrix}. \quad (25)$$

The expression for the PID controller parameters is now much simpler when compared to expressions (12)-(14). There are several other advantages to using expression (25) instead of expressions (12)-(14) for the calculation of the PID controller parameters.

First, only the steady-state process gain $A_0=K_{PR}$ and five moments (A_1 to A_5) instead of the 12 transfer function parameters (K_{PR} , $a_1..a_5$, $b_1..b_5$, and T_{delay}) are needed as input data.

Second, the expression for K_I , K_P , and K_D is simplified, which makes it more transparent and simpler to handle.

Third, the moments A_1 to A_5 can be calculated from the process time-response using numerical integration, whilst the gain $A_0=K_{PR}$ can be determined from the steady-state value of the process steady-state change in the usual way. This procedure replaces the much more demanding algorithm for the estimation of the transfer function parameters.

In addition, it is important to note that the mapping of expressions (12)-(14) into expression (25) results in exact (rather than approximate) controller parameters. This means that the frequency-domain control criterion can be achieved with a model parameterised in the time-domain. Thus the proposed tuning procedure is a simple and very effective way for controller tuning since no background in control theory is needed.

Note that the calculation of the filtered PID controller parameters is based on the fact that the filter time constant is given *a priori*. In practice this is often not entirely true, since the usual way is rather to define the ratio (N) between the derivative time constant ($T_D=K_D/K_P$) and the filter time constant:

$$N = \frac{T_D}{T_F} = \frac{K_D}{K_P T_F}. \quad (26)$$

Typical values of N are 8 to 20 (Åström & Hägglund, 1995).

The controller parameters can be calculated iteratively by first choosing $T_F=0$ (or any relatively small positive value) and then calculating the controller parameters by using expression (25). In the second iteration, the filter time constant can be calculated from (26), as follows:

$$T_F = \frac{K_D}{K_P N}. \quad (27)$$

The moments are recalculated according to expression (24) and the new controller parameters from (25). By performing a few more iterations, quite accurate results can be obtained for the *a priori* chosen ratio N .

The PI controller parameters can be calculated in a similar manner to those of the PID controller by choosing $K_D=0$. Since a filter is usually not needed in a PI controller ($T_F=0$), the original moments (A_i) are applied in the calculation. Repeating the same procedure as before and solving the first two equations in (9), the following PI controller parameters are obtained (Vrančić et al., 2001a):

$$\begin{bmatrix} K_I \\ K_P \end{bmatrix} = \begin{bmatrix} -A_1 & A_0 \\ -A_3 & A_2 \end{bmatrix}^{-1} \begin{bmatrix} -0.5 \\ 0 \end{bmatrix}. \quad (28)$$

Note that the vectors and matrices in (28) are just sub-vectors and sub-matrices of expression (25). Similarly, the I (integral-term only) controller gain is the following:

$$K_I = \frac{0.5}{A_1}. \quad (29)$$

The proportional (P) controller gain can be obtained by fixing $K_I=0$ and $K_D=0$, repeating the procedure and solving the first equation in (9):

$$K_P = \frac{2A_0A_2 - A_1^2}{2A_0(A_1^2 - A_0A_2)}. \quad (30)$$

However, condition (6) is not satisfied, since proportional controllers cannot achieve closed-loop gain equal to one at lower frequencies. Therefore the proportional controller does not entirely fulfil the MO conditions and will not be used in any further derivations.

In some cases, the controller parameters have to be re-tuned for certain practical reasons. In particular, when tuning the PID controllers for the first-order or the second-order process, the controller gain is theoretically infinite. In practice (when there is process noise), the

calculated controller gain can have a very high positive or negative value. In this case, the controller gain should be limited to some acceptable value, which would depend on the controller and the process limitations (Vrančić et al., 1999). Note that the sign of the proportional gain is usually the same to the sign of the process gain:

$$\text{sgn}(K_P) = \text{sgn}(K_{PR}). \quad (31)$$

The recommended values of the proportional gain are:

$$\left| \frac{1}{A_0} \right| \leq |K_P| \leq \left| \frac{10}{A_0} \right|. \quad (32)$$

The remaining two controller parameters can now be calculated according to the limited (fixed) controller gain from expression (25). If the chosen controller gain is:

$$K_P > \frac{1}{\frac{2A_1^*A_2^*}{A_3^*} - 2A_0^*}, \quad (33)$$

then:

$$K_I = \frac{0.5 + K_P A_0^*}{A_1^*} \quad (34)$$

and:

$$K_D = \frac{A_3^*}{A_1^{*2}} \left[\frac{A_1^* A_2^* K_P}{A_3^*} - 0.5 - A_0^* K_P \right]. \quad (35)$$

If expression (33) is not true:

$$K_D = 0. \quad (36)$$

When limiting the proportional gain of the PI controller, only Eq. (34) is used. Note that proposed re-tuning can also be used in cases when a slower and more robust controller should be designed (by decreasing K_P), or if a faster but more oscillatory response is required (by increasing K_P).

The PID controller tuning procedure, according to the MOMI method, can therefore proceed as follows:

- If the process model is not known *a priori*, modify the steady-state process by changing the process input signal.
- Find the steady-state process gain $K_{PR}=A_0$ and moments A_1 - A_5 by using numerical integration (summation) from the beginning to the end of the process time response according to expressions (17) and (18). If the process model is known, calculate the moments from expression (20).
- Fix the filter time constant T_F to some desired value and calculate the PID controller parameters from (25). If needed, change the filter time constant and recalculate the PID controller parameters. If the proportional gain K_P is too high or has a different sign to

the process gain ($K_{PR}=A_0$), set K_P manually to some desired value (32) and recalculating remaining parameters according to expressions (33)-(36).

- The PI or I parameters can be calculated from expressions (28) or (29), respectively. The proposed tuning procedure will be illustrated by the following process models:

$$\begin{aligned}
 G_{P1}(s) &= \frac{1}{(1+2s)^2(1+s)^2} \\
 G_{P2}(s) &= \frac{1}{(1+s)^6} \\
 G_{P3}(s) &= \frac{1-4s}{(1+s)^2} \\
 G_{P4}(s) &= \frac{e^{-5s}}{1+s}
 \end{aligned}
 \tag{37}$$

The process models have been chosen in order to cover a range of different processes, including higher-order processes, highly non-minimum phase processes and dominantly delayed processes. The models have the same process gain ($A_0=1$) and the first moment $A_1=6$. If the process transfer function is not known in advance, the moments (areas) can be calculated according to the time-domain approach given above. The ramp-like input signal has been applied to the process inputs. The process open-loop responses are shown in Figure 4.

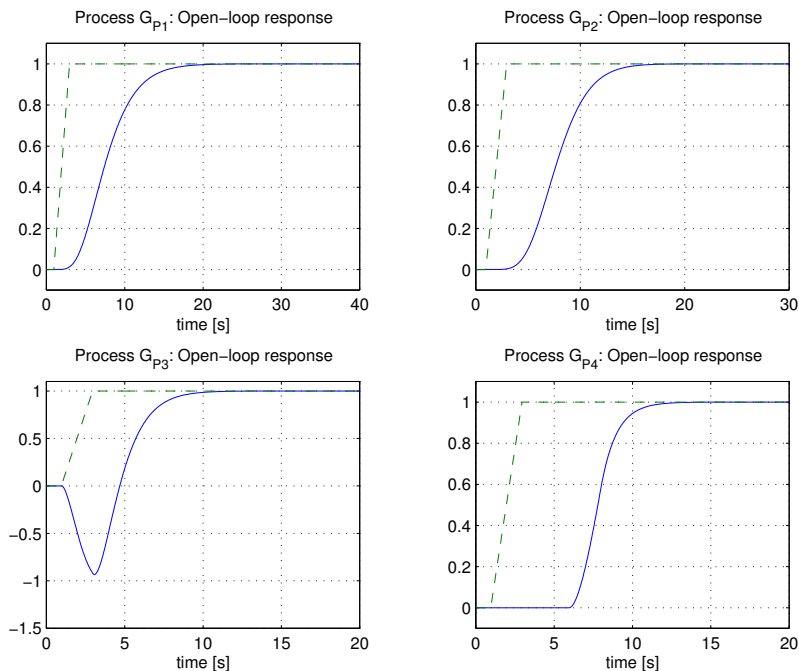

Fig. 4. The process input (--) and the process output (—) signals during an open-loop experiment for processes G_{P1} to G_{P4} .

The moments are calculated by using expressions (17) and (18) and the controller parameters by using expressions (25), (28) and (29). The calculated parameters are given in Table 1.

	Moments (areas)					PID				PI		I
	A ₁	A ₂	A ₃	A ₄	A ₅	K _I	K _P	K _D	T _F	K _I	K _P	K _I
G _{P1}	6	23	72	201	521	0.31	1.45	1.76	0.2	0.17	0.55	0.08
G _{P2}	6	21	56	126	252	0.22	0.87	0.96	0.2	0.15	0.4	0.08
G _{P3}	6	11	16	21	26	0.12	0.25	0.13	0.2	0.11	0.16	0.08
G _{P4}	6	18.5	39.3	65.4	91.3	0.16	0.49	0.45	0.2	0.13	0.27	0.08

Table 1. The values of moments and controller parameters for processes (37) when using a time-domain approach (by applying multiple integration of the process time-response).

The closed-loop responses for all the processes, when using different types of controllers tuned by the MOMI method, are shown in Figure 5. As can be seen, the responses are stable and relatively fast, all according to the MO tuning criteria.

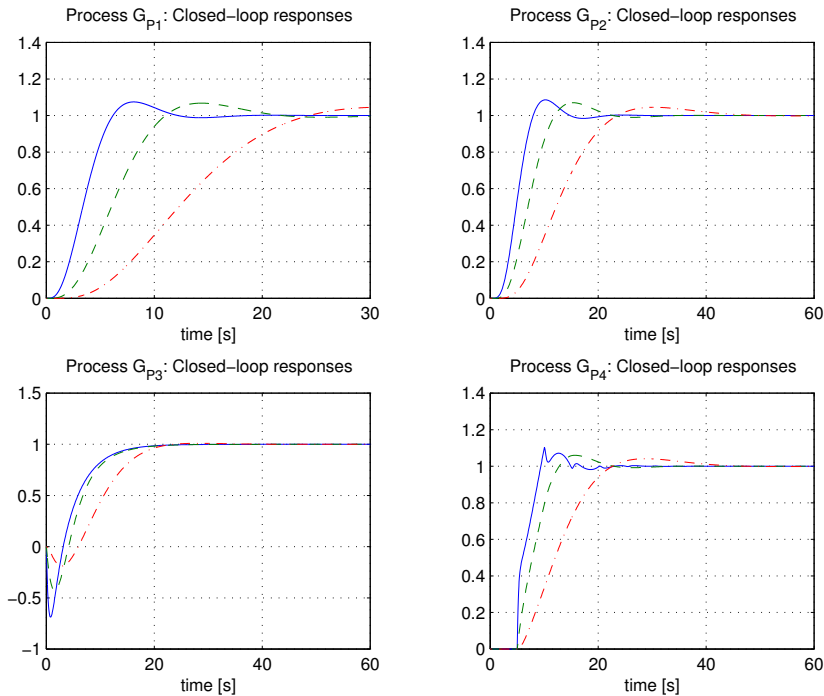

Fig. 5. Closed-loop responses for processes G_{P1} to G_{P4} when using PID controller (—), PI controller (---) and I controller (-.-) tuned by the MOMI method.

The results can be verified by calculating the moments and controller parameters directly from the process transfer functions (37). The moments can be calculated from expression (20). The controller parameters are calculated as before. The obtained parameters are given

in Table 2. It can be seen that the values are practically equivalent, so the closed-loop responses are the same to those shown in Figure 5.

	Moments (areas)					PID				PI		I
	A ₁	A ₂	A ₃	A ₄	A ₅	K _I	K _P	K _D	T _F	K _I	K _P	K _I
G _{P1}	6	23	72	201	522	0.31	1.44	1.76	0.2	0.17	0.55	0.08
G _{P2}	6	21	56	126	252	0.22	0.87	0.96	0.2	0.15	0.4	0.08
G _{P3}	6	11	16	21	26	0.12	0.25	0.13	0.2	0.11	0.16	0.08
G _{P4}	6	18.5	39.3	65.4	91.4	0.16	0.49	0.45	0.2	0.13	0.27	0.08

Table 2. The values of moments and controller parameters for processes (37) by using direct calculation from the process model.

The MOMI tuning method will be illustrated by the three-water-column laboratory setup shown in Figure 6. It consists of two water pumps, a reservoir and three water columns. The water columns can be connected by means of electronic valves. In our setup, two water columns have been used (R_1 and R_2), as depicted in the block diagram shown in Figure 7.

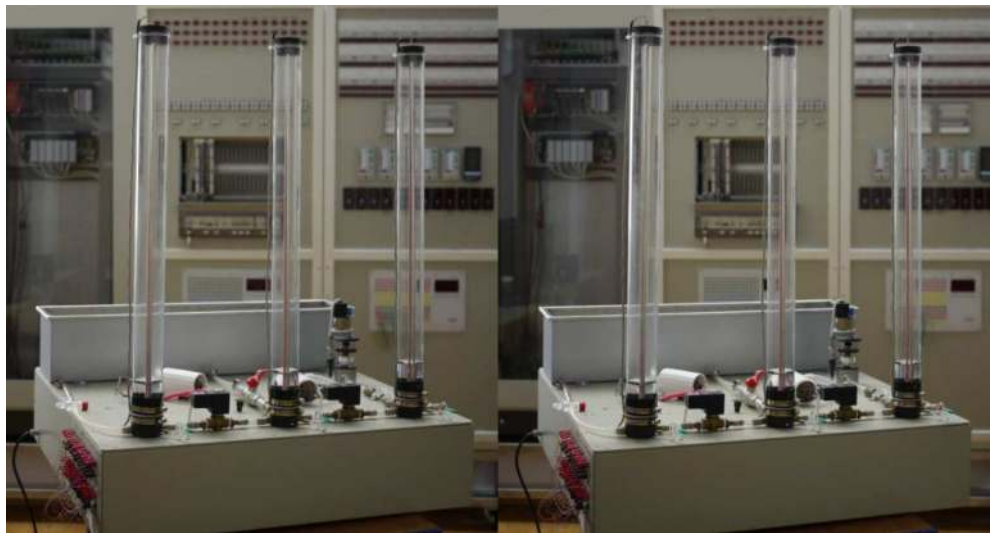

Fig. 6. Picture of the laboratory hydraulic setup (taken in stereoscopic side-by-side format).

The selected control loop consists of the reservoir R_0 , the pump P_1 , an electronic valve V_1 (open), a valve V_3 (partially open) and water columns R_1 and R_2 . The valve V_2 is closed and the pump P_2 is switched off. The process input is the voltage on pump P_1 and the process output is the water level in the second tank (h_2), measured by the pressure to voltage transducer. The actual process input and output signals are voltages measured by an A/D and a D/A converter (NI USB 6215) via real-time blocks in Simulink (Matlab).

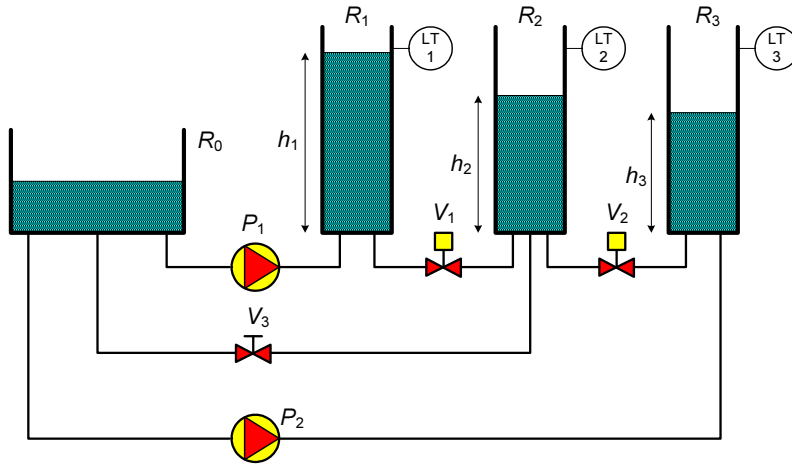

Fig. 7. Block diagram of the laboratory hydraulic setup.

First, the linearity of the system was checked by applying several steps at the process input. The process input and output responses are shown in Figure 8. It can be seen that both - the process steady-state gain and the time-constants - change according to the working point. In order to partially linearise the process, the square-root function has been placed between the controller output (u) and the process input (u^r) signals:

$$u^r = \sqrt{10 \cdot u} , \quad (38)$$

The control output signal u is limited between values 0 and 10. The pump actually starts working when signal u^r becomes higher than 1V.

Note that artificially added non-linearity cannot ideally linearise the non-linearity of the process gain. Moreover, the process time constants still differ significantly at different working points.

After applying the non-linear function (38), the open-loop process response has been measured (see Figure 9). The moments (areas) have been calculated by using expressions (17) and (18):

$$A_0 = 0.507, A_1 = 33.9, A_2 = 1.76 \cdot 10^3, A_3 = 8.44 \cdot 10^4, A_4 = 3.9 \cdot 10^6, A_5 = 1.78 \cdot 10^8 \quad (39)$$

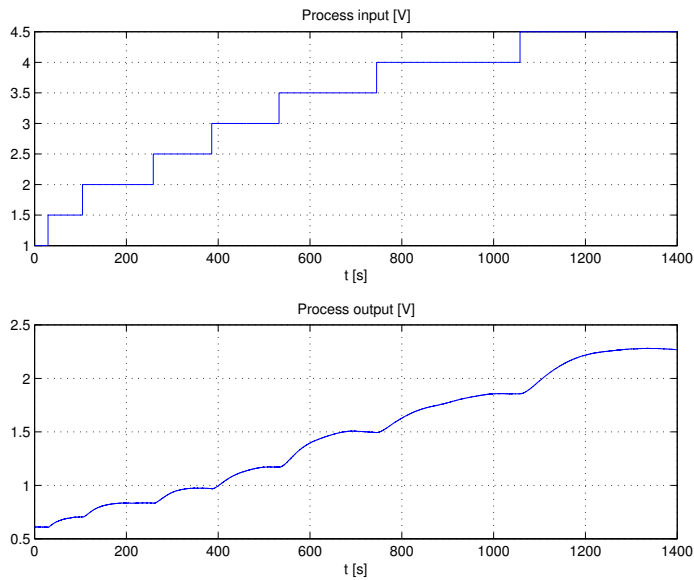

Fig. 8. The process input and process output responses over the entire working region.

The calculated PID controller parameters, for an *a priori* chosen filter parameter $T_F=1s$, were the following (the proportional gain has been limited to the value $K_P=10/A_0$):

$$K_I = 0.305, K_P = 19.7, K_D = 264 \tag{40}$$

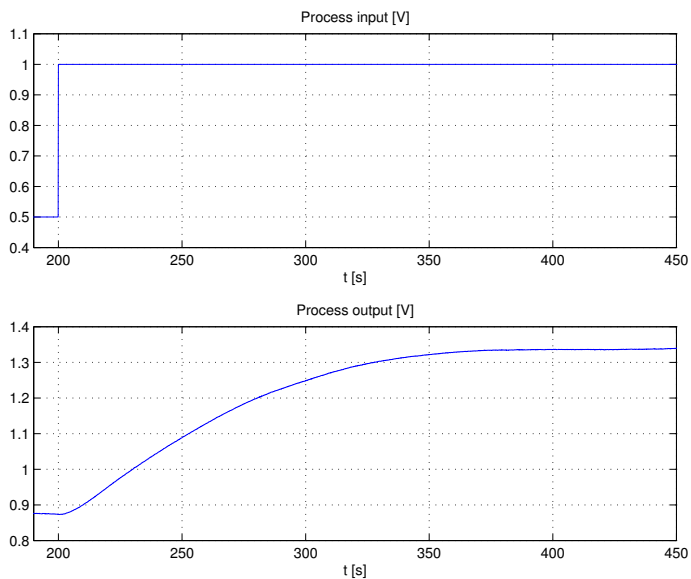

Fig. 9. Process open-loop response.

The closed-loop response of the process with the controller was calculated in the previous step, as shown in Figure 10. At $t=300\text{s}$, the set-point has been changed from 1.2 to 1.5 and at $t=900\text{s}$ it is returned back to 1.2. A step-like disturbance has been added to the process input at $t=700\text{s}$ and $t=1300\text{s}$. It can be seen that the closed-loop response is relatively fast (when compared to the open-loop response) and without oscillations.

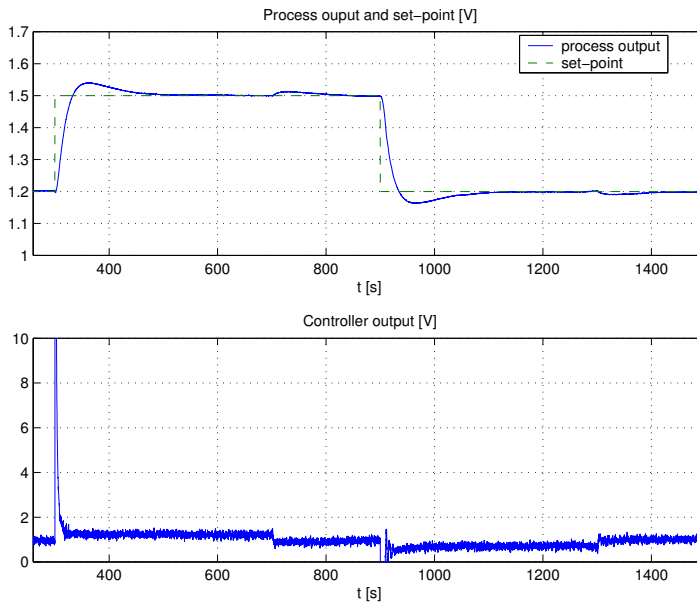

Fig. 10. The process closed-loop response in the hydraulic setup when using the PID controller tuned by the MOMI method.

5. Disturbance-Rejection Magnitude Optimum (DRMO) tuning method

The efficiency of the MOMI method has been demonstrated on several process models (Vrančić, 1995). The MO criteria, according to expressions (6) and (7), optimises the closed-loop transfer function between the reference (r) and the process output (y). However, this may lead to the poor attenuation of load disturbances (Åström & Häggglund, 1995). The disturbance-rejection performance is particularly degraded when controlling lower-order processes.

Let us observe the disturbance-rejection performance of the following process models:

$$\begin{aligned}
 G_{P1}(s) &= \frac{1}{(1+6s)} \\
 G_{P2}(s) &= \frac{1}{(1+3s)^2} \\
 G_{P3}(s) &= \frac{1}{(1+s)^6} \\
 G_{P4}(s) &= \frac{e^{-5s}}{1+s}
 \end{aligned}
 \tag{41}$$

Two of them (G_{P3} and G_{P4}) are the same as in the previous section (37) while we added two lower-order processes in order to clearly show the degraded disturbance-rejection performance. The moments and controller parameters for the chosen processes are given in Table 3. Note that the proportional gain has been limited to 10 for G_{P1} and G_{P2} .

	Moments (areas)					PID				PI		I
	A ₁	A ₂	A ₃	A ₄	A ₅	K _I	K _P	K _D	T _F	K _I	K _P	K _I
G _{P1}	6	36	216	1296	7776	1.75	10	0	0	1.75	10	0.08
G _{P2}	6	27	108	405	1458	1.69	10	14.5	0.2	0.25	1	0.08
G _{P3}	6	21	56	126	252	0.22	0.87	0.96	0.2	0.15	0.4	0.08
G _{P4}	6	18.5	39.3	65.4	91.4	0.16	0.49	0.45	0.2	0.13	0.27	0.08

Table 3. The values of the moments and controller parameters for processes (41) using the MOMI method.

A step-like disturbance (d) has been applied to the process input (see Figure 1). The process output responses are shown in Figure 11. It is clearly seen that the closed-loop responses of the processes G_{P1} and G_{P2} , when using the PI and the PID controllers, are relatively slow with visible “long tails” (exponential approaching to the reference).

It is obvious that the MO criteria should be modified in order to achieve a more optimal disturbance rejection. The closed-loop transfer function between the disturbance (d) and the process output (y) is the following:

$$G_{CLD}(s) = \frac{Y(s)}{D(s)} = \frac{G_P(s)}{1 + G_C(s)G_P(s)}
 \tag{42}$$

However, the function G_{CLD} (42) cannot be applied instead of G_{CL} in expressions (6) and (7), since G_{CLD} has zero gain in the steady-state ($s=0$). However, by adding integrator to function (42) and multiplying it with K_I , it complies with the MO requirements (Vrančić et al., 2004b; 2010):

$$G_{CLI}(s) = \frac{K_I}{s} G_{CLD}(s) = \frac{K_I G_P(s)}{s(1 + G_C(s)G_P(s))}
 \tag{43}$$

Therefore, in order to achieve optimal disturbance-rejection properties, the function G_{CLI} should be applied instead of G_{CL} in the MO criteria (6) and (7).

However, the expression for the PID controller parameters – due to higher-order equations – is not analytic and the optimisation procedure should be used (Vrančić et al., 2010). Initially, the derivative gain K_D is calculated from expression (25). As such, the proportional and integral term gains are calculated as follows (Vrančić et al., 2010):

$$K_P = \frac{\beta - \sqrt{\beta^2 - \alpha\gamma}}{\alpha}$$

$$K_I = \frac{(1 + K_P A_0^*)^2}{2(K_D A_0^{*2} + A_1^*)}$$
(44)

where

$$\alpha = A_1^{*3} + A_0^{*2} A_3^* - 2A_0^* A_1^* A_2^*$$

$$\beta = A_1^* A_2^* - A_0^* A_3^* + K_D (A_0^* A_1^{*2} - A_0^{*2} A_2^*)$$

$$\gamma = K_D^3 A_0^{*4} + 3K_D^2 A_0^{*2} A_1^* + K_D (2A_0^* A_2^* + A_1^{*2}) + A_3^*$$
(45)

The optimisation iteration steps consist of modifying the derivative gain K_D and recalculating the remaining two parameters from (44) until the following expression becomes true (Vrančić et al., 2010):

$$-4A_0 A_4 K_I K_D - 2A_3 K_D + 2A_4 K_P - 2A_5 K_I + 2A_0 A_4 K_P^2 - 2A_0 A_2 K_D^2 -$$

$$-2A_1 A_3 K_P^2 - 2A_2^2 K_I K_D + A_1^2 K_D^2 + A_2^2 K_P^2 + 4A_1 A_3 K_D K_I = 0$$
(46)

Any method that employs an iterative search for a numeric solution – that solves the system of nonlinear equations – can be applied. However, in Vrančić et al. (2004a) it was shown that the initially calculated parameters of the PID controller are usually very close to optimal ones. Therefore, a simplified (sub-optimal) solution is to use only the initial PID parameters. In the following text, the simplified version will be applied and denoted as the DRMO tuning method.

Note that the PI controller parameters do not require any optimisation procedure. The derivative gain is fixed at $K_D=0$ and the PI controller parameters are then calculated from expression (44).

The PID controller tuning procedure, according to the DRMO method, can therefore proceed as follows:

- If the process model is not known *a priori*, modify the process steady-state by changing the process input signal.
- Find the steady-state process gain $K_{PR}=A_0$ and moments A_1 - A_5 by using numerical integration (summation) from the beginning to the end of the process step response according to expressions (17) and (18). If the process model is defined, calculate the gain and moments from expression (20).
- Fix the filter time constant T_F to some desired value and calculate moments and the derivative gain K_D from (24) and (25). Calculate the remaining controller parameters from expression (44). If the value $\alpha=0$ or if the proportional gain K_P is too high or has a

different sign to the process gain ($K_{PR}=A_0$), set K_P manually to some more suitable value and then recalculate K_I from (44).

- The PI controller parameters can be calculated by fixing $K_D=0$ and using expression (44). If the value $\alpha=0$ or if the proportional gain K_P is too high or has a different sign to the process gain ($K_{PR}=A_0$), set K_P manually to some more suitable value and then recalculate K_I from (44).

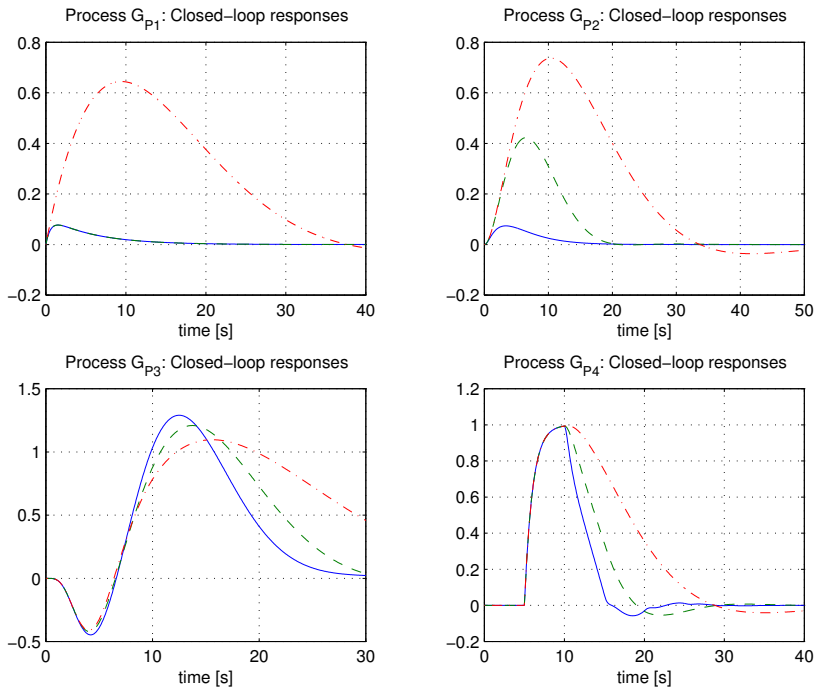

Fig. 11. Closed-loop responses to step-like input disturbance (d) for processes G_{P1} to G_{P4} when using a PID controller (—), a PI controller (---) and an I controller (-.-) tuned by the MOMI method.

The proposed DRMO tuning procedure will be illustrated by the same four process models (41), as before. The PID and PI controllers' parameters are calculated by the procedure given above. Note that the I controller parameters remain the same as with the MOMI method (29). The parameters for all of the controllers are given in Table 4.

	Moments (areas)					PID				PI		I
	A_1	A_2	A_3	A_4	A_5	K_I	K_P	K_D	T_F	K_I	K_P	K_I
G_{P1}	6	36	216	1296	7776	10.1	10	0	0	1.75	10	0.08
G_{P2}	6	27	108	405	1458	2.92	10	14.5	0.2	0.25	1	0.08
G_{P3}	6	21	56	126	252	0.27	0.97	0.96	0.2	0.17	0.43	0.08
G_{P4}	6	18.5	39.3	65.4	91.4	0.18	0.52	0.45	0.2	0.14	0.29	0.08

Table 4. The values of moments and controller parameters for processes (41) using the DRMO method.

A step-like disturbance (d) has been applied to the process input. The process output responses, when using the PID and the PI controllers, are shown in Figures 12 and 13. It can be clearly seen that the closed-loop performance for processes G_{P1} and G_{P2} is now improved when compared with the original MOMI method.

However, improved disturbance-rejection has its price. Namely, the optimal controller parameters for disturbance-rejection are usually not optimal for reference following. Deterioration in tracking performance, in the form of larger overshoots, can be expected for the lower-order processes. A possible solution for improving deteriorated tracking performance, while retaining the obtained disturbance-rejection performance, is to use a 2-DOF PID controller, as shown in Figure 1. Namely, it has been shown that tracking performance can be optimised by choosing $b=c=0$ (Vrančić et al., 2010). The closed-loop responses on a step-wise reference changes and input disturbances (at the mid-point of the experiment) are shown in Figures 14 and 15. It can be seen that the overshoots are reduced when using $b=c=0$ while retaining disturbance-rejection responses.

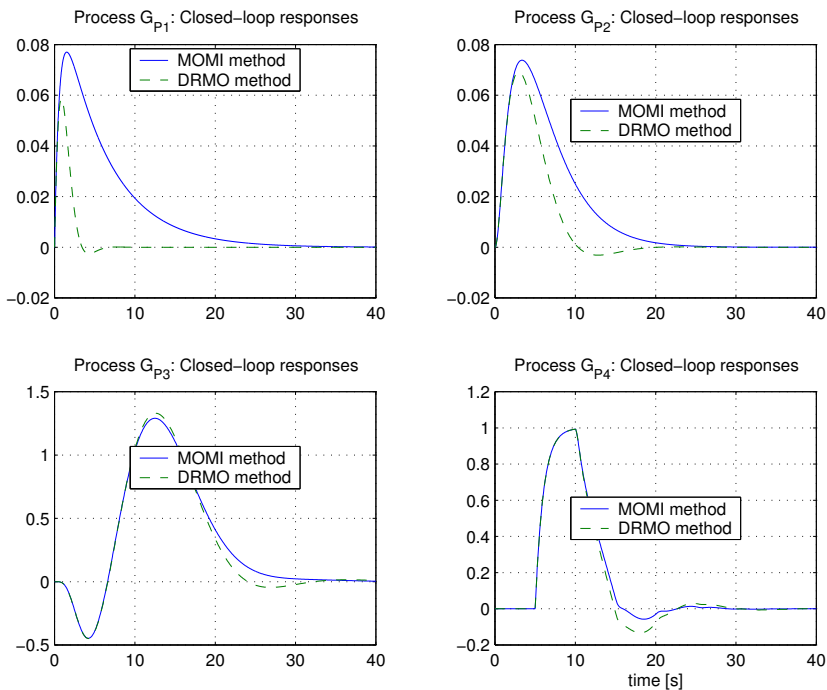

Fig. 12. A comparison of process output disturbance-rejection performance for processes G_{P1} to G_{P4} when using a PID controller tuned by the MOMI (—) and DRMO (---) tuning methods.

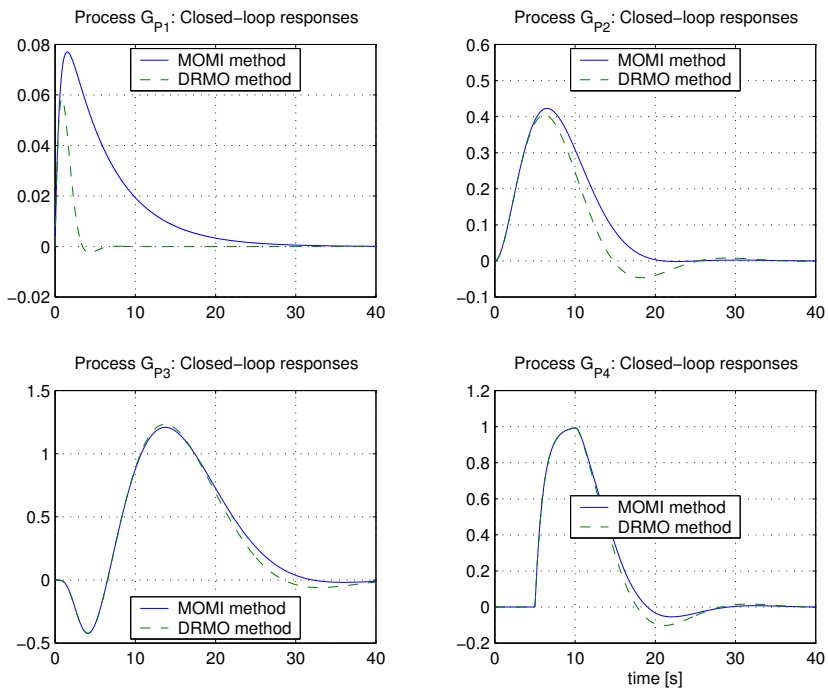

Fig. 13. A comparison of process output disturbance rejection performance for processes G_{P1} to G_{P4} when using a PI controller tuned by the MOMI (—) and DRMO (---) tuning methods.

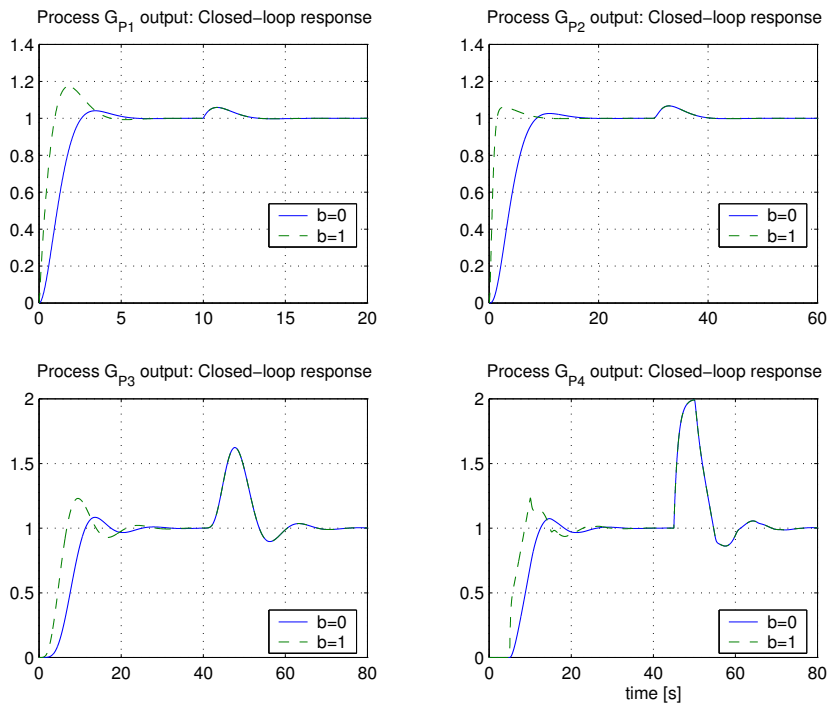

Fig. 14. Process output tracking and disturbance-rejection performance for processes G_{p1} to G_{p4} when using a PID controller tuned by the DRMO tuning method for the controller parameters $b=c=0$ and $b=c=1$.

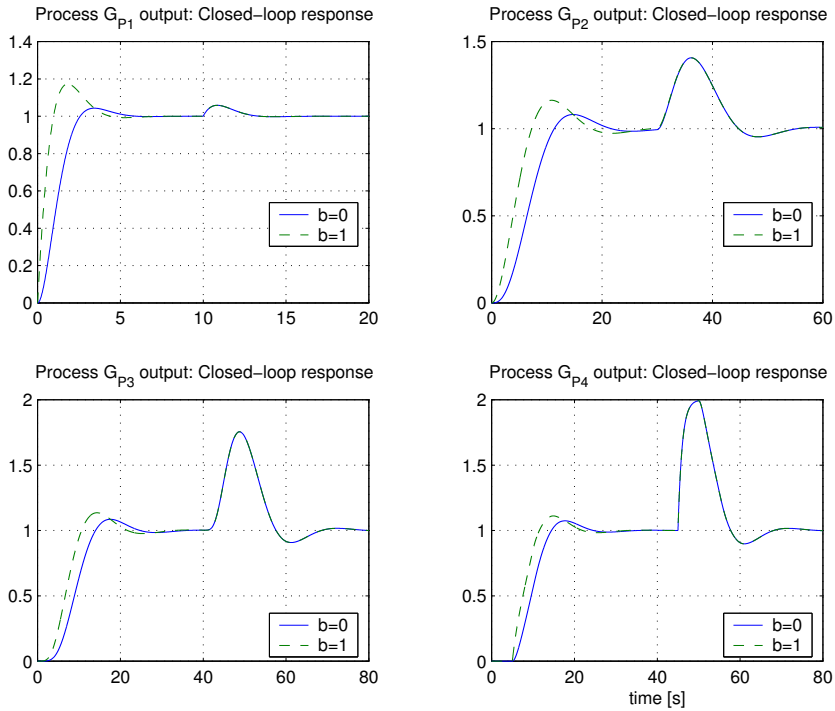

Fig. 15. Process output tracking and disturbance-rejection performance for processes G_{P1} to G_{P4} when using a PI controller tuned by the DRMO tuning method for the controller parameters $b=c=0$ and $b=c=1$.

The DRMO tuning method will be illustrated on the same three-water-column laboratory setup, described in the previous section. According to the previously calculated values of moments (39), the PID controller parameters are the following (the proportional gain has been limited to value $K_P=10/A_0$) for the chosen $T_F=1s$:

$$K_I = 0.59, K_P = 19.7, K_D = 264 \tag{47}$$

The closed-loop responses, when setting the parameter $b=c=0.1$, are shown in Figure 16. Similarly, as with the MOMI method, the set-point has been changed from 1.2 to 1.5 at $t=300s$ and is returned to 1.2 at $t=900s$. A step-like disturbance has been added to the process input at $t=700s$ and $t=1300s$. The disturbance rejection performance is now improved when compared with Figure 10. A comparison of responses obtained by the MOMI and the DRMO methods with PID controllers is shown in Figure 17. It is clear that the tracking response is slower and with a smaller overshoot, while the disturbance-rejection is significantly improved.

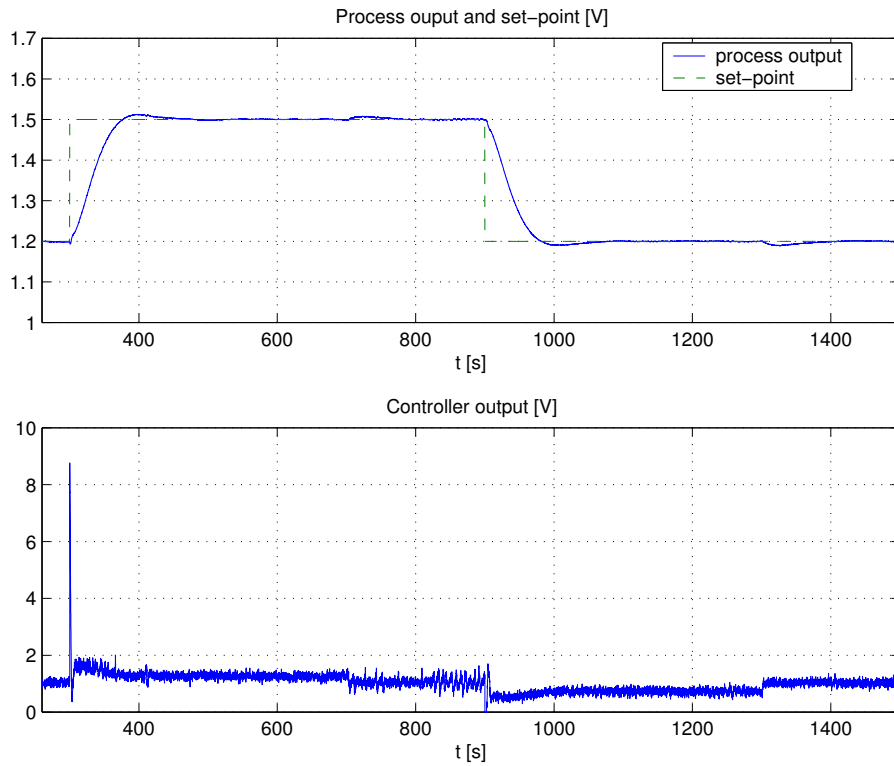

Fig. 16. The process closed-loop response in the hydraulic setup when using the PID controller tuned by the DRMO method.

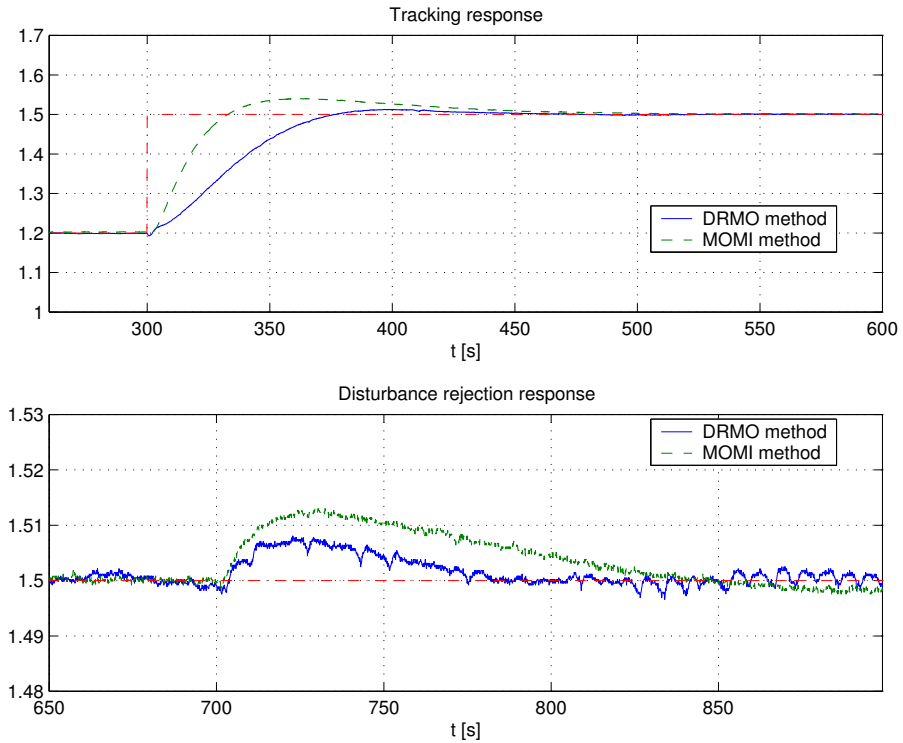

Fig. 17. A comparison of the process closed-loop responses in the hydraulic setup with PID controllers tuned by the MOMI and DRMO methods.

6. Conclusion

The purpose of this Chapter is to present tuning methods for PID controllers which are based on the Magnitude Optimum (MO) method. The MO method usually results in fast and stable closed-loop responses. However, it is based on demanding criteria in the frequency domain, which requires the reliable estimation of a large number of the process parameters. In practice, such high demands cannot often be satisfied.

It was shown that the same MO criteria can be satisfied by performing simple time-domain experiments on the process (steady-state change of the process). Namely, the process can be parameterised by the moments (areas) which can be simply calculated from the process steady-state change by means of repetitive integrations of time responses. Hence, the method is called the “Magnitude Optimum Multiple Integration” (MOMI) method. The measured moments can be directly used in the calculation of the PID controller parameters without making any error in comparison with the original MO method. Besides this, from the time domain responses, the process moments can also be calculated from the process transfer function (if available). Therefore, the MOMI method can be considered to be a universal method which can be used either with the process model or the process time-responses.

The MO (and therefore the MOMI) method optimises the closed-loop tracking performance (from the reference to the process output). This may lead to a degraded disturbance-rejection performance, especially for lower-order processes. In order to improve the disturbance-rejection performance, the MO criteria have been modified. The modification was based on optimising the integral of the closed-loop transfer function from the process input (load disturbance) to the process output. Hence, the method is called the “Disturbance-Rejection Magnitude Optimum” (DRMO) method.

The MOMI and the DRMO tuning methods have been tested on several process models and on one hydraulic laboratory setup. The results of the experiments have shown that both methods give stable and fast closed-loop responses. The MOMI method optimises tracking performance while the DRMO method improves disturbance-rejection performance. By using a two-degrees-of-freedom (2-DOF) PID controller structure, the optimal disturbance-rejection and improved tracking performance have been obtained simultaneously.

The MOMI and DRMO methods are not limited to just PID controller structures or stable (self-regulatory) processes. The reader can find more information about different controller structures and types of processes in Vrančić (2008), Vrančić & Huba (2011), Vrečko et al., (2001), Vrančić et al., (2001b) and in the references therein.

The drawback of the MO method (and therefore the MOMI method and, to an extent, the DRMO method) is that stability is not guaranteed if the controller is of a lower-order than the process. Therefore, unstable closed-loop responses may be obtained on some processes containing stronger zeros or else complex poles. Although the time-domain implementation of the method is not very sensitive to high-frequency process noise (due to multiple integrations of the process responses), the method might give sub-optimal results if low-frequency disturbances are present during the measurement of the process steady-state change.

7. Acknowledgments

The author gratefully acknowledges the contribution of the Ministry of Higher Education, Science and Technology of the Republic of Slovenia, Grant No. P2-0001.

8. References

- Åström, K. J., & Hägglund, T. (1995). PID controllers: Theory, design, and tuning. Instrument Society of America Research Triangle Park (2nd ed.).
- Åström, K. J., Panagopoulos, H. & Hägglund, T. (1998). Design of PI Controllers based on Non-Convex Optimization. *Automatica*, 34 (5), pp. 585-601.
- Ba Hli, F. (1954). A General Method for Time Domain Network Synthesis. *IRE Transactions - Circuit Theory*, 1 (3), pp. 21-28.
- Gorez, R. (1997). A survey of PID auto-tuning methods. *Journal A*. Vol. 38, No. 1, pp. 3-10.
- Hanus, R. (1975). Determination of controllers parameters in the frequency domain. *Journal A*, XVI (3).

- Huba, M. (2006). Constrained pole assignment control. *Current Trends in Nonlinear Systems and Control*, L. Menini, L. Zaccarian, Ch. T. Abdallah, Edts., Boston: Birkhäuser, pp. 163-183.
- Kessler, C. (1955). Über die Vorausberechnung optimal abgestimmter Regelkreise Teil III. Die optimale Einstellung des Reglers nach dem Betragsoptimum. *Regelungstechnik*, Jahrg. 3, pp. 40-49.
- Preuss, H. P. (1991). Model-free PID-controller design by means of the method of gain optimum (in German). *Automatisierungstechnik*, Vol. 39, pp. 15-22.
- Rake, H. (1987). Identification: Transient- and frequency-response methods. In M. G. Singh (Ed.), *Systems & control encyclopedia; Theory, technology, applications*. Oxford: Pergamon Press.
- Strejc, V. (1960). Auswertung der dynamischen Eigenschaften von Regelstrecken bei gemessenen Ein- und Ausgangssignalen allgemeiner Art. *Z. Messen, Steuern, Regeln*, 3(1), pp. 7-10
- Umland, J. W. & M. Safiuddin (1990). Magnitude and symmetric optimum criterion for the design of linear control systems: what is it and how does it compare with the others? *IEEE Transactions on Industry Applications*, 26 (3), pp. 489-497.
- Vrančić, D. (1995). A new PI(D) tuning method based on the process reaction curve, Report DP-7298, J. Stefan Institute, Ljubljana.
Available on <http://dsc.ijs.si/Damir.Vrancic/bibliography.html>
- Vrančić, D. (2008). MOMI Tuning Method for Integral Processes. *Proceedings of the 8th Portuguese Conference on Automatic Control*, Vila Real, July 21-23, pp. 595-600.
- Vrančić, D. & Huba, M. (2011). Design of feedback control for unstable processes with time delay. *Proceedings of the 18th International Conference on Process Control*. June 14-17, Tatranska Lomnica, Slovakia, pp. 100-105.
- Vrančić, D. Kocijan, J. & Strmčnik, S. (2004a). Simplified Disturbance Rejection Tuning Method for PID Controllers. *Proceedings of the 5th Asian Control Conference*. July 20-23, Melbourne, pp. 491-496.
- Vrančić, D., Lieslehto, J. & Strmčnik, S. (2001b). Designing a MIMO PI controller using the multiple integration approach. *Process Control and Quality*, Vol. 11, No. 6, pp. 455-468.
- Vrančić, D., Peng, Y. & Strmčnik, S. (1999). A new PID controller tuning method based on multiple integrations. *Control Engineering Practice*, Vol. 7, pp. 623-633.
- Vrančić, D., Strmčnik S. & Kocijan J. (2004b). Improving disturbance rejection of PI controllers by means of the magnitude optimum method. *ISA Transactions*. Vol. 43, pp. 73-84.
- Vrančić, D., Strmčnik S., Kocijan J. & Moura Oliveira, P. B. (2010). Improving disturbance rejection of PID controllers by means of the magnitude optimum method. *ISA Transactions*. Vol. 49, pp. 47-56.
- Vrančić, D., Strmčnik S. & Juričić Đ. (2001a). A magnitude optimum multiple integration method for filtered PID controller. *Automatica*. Vol. 37, pp. 1473-1479.
- Vrečko, D., Vrančić, D., Juričić Đ. & Strmčnik S. (2001). A new modified Smith predictor: the concept, design and tuning. *ISA Transactions*. Vol. 40, pp. 111-121.

Whiteley, A. L. (1946). Theory of servo systems, with particular reference to stabilization. The Journal of IEE, Part II, 93(34), pp. 353-372.

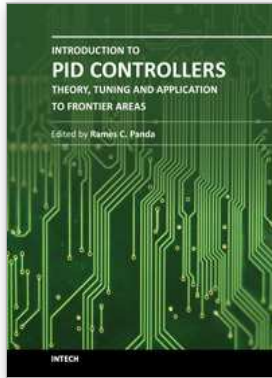

Introduction to PID Controllers - Theory, Tuning and Application to Frontier Areas

Edited by Prof. Ramesh C. Panda

ISBN 978-953-307-927-1

Hard cover, 258 pages

Publisher InTech

Published online 29, February, 2012

Published in print edition February, 2012

This book discusses the theory, application, and practice of PID control technology. It is designed for engineers, researchers, students of process control, and industry professionals. It will also be of interest for those seeking an overview of the subject of green automation who need to procure single loop and multi-loop PID controllers and who aim for an exceptional, stable, and robust closed-loop performance through process automation. Process modeling, controller design, and analyses using conventional and heuristic schemes are explained through different applications here. The readers should have primary knowledge of transfer functions, poles, zeros, regulation concepts, and background. The following sections are covered: The Theory of PID Controllers and their Design Methods, Tuning Criteria, Multivariable Systems: Automatic Tuning and Adaptation, Intelligent PID Control, Discrete, Intelligent PID Controller, Fractional Order PID Controllers, Extended Applications of PID, and Practical Applications. A wide variety of researchers and engineers seeking methods of designing and analyzing controllers will create a heavy demand for this book: interdisciplinary researchers, real time process developers, control engineers, instrument technicians, and many more entities that are recognizing the value of shifting to PID controller procurement.

How to reference

In order to correctly reference this scholarly work, feel free to copy and paste the following:

Damir Vrančić (2012). Magnitude Optimum Techniques for PID Controllers, Introduction to PID Controllers - Theory, Tuning and Application to Frontier Areas, Prof. Ramesh C. Panda (Ed.), ISBN: 978-953-307-927-1, InTech, Available from: <http://www.intechopen.com/books/introduction-to-pid-controllers-theory-tuning-and-application-to-frontier-areas/tuning-of-pid-controllers-based-on-magnitude-optimum>

INTECH
open science | open minds

InTech Europe

University Campus STeP Ri
Slavka Krautzeka 83/A
51000 Rijeka, Croatia
Phone: +385 (51) 770 447
Fax: +385 (51) 686 166
www.intechopen.com

InTech China

Unit 405, Office Block, Hotel Equatorial Shanghai
No.65, Yan An Road (West), Shanghai, 200040, China
中国上海市延安西路65号上海国际贵都大饭店办公楼405单元
Phone: +86-21-62489820
Fax: +86-21-62489821

© 2012 The Author(s). Licensee IntechOpen. This is an open access article distributed under the terms of the [Creative Commons Attribution 3.0 License](#), which permits unrestricted use, distribution, and reproduction in any medium, provided the original work is properly cited.