

## Chapter

# Design and Evaluation of an Automated Monitoring and Control System for Greenhouse Crop Production

*Arasu Sivagami, Michael Angelo Kandavalli  
and Bhaskarrao Yakkala*

## Abstract

An embedded system integrated with sensors based on nanomaterial is proposed for closely monitoring and control microclimate parameters 24 hours a day to maximise production over the whole crop growth season by introducing greenhouse for the cultivation of plants or specific plant species. The system will also eliminate errors in human intervention to optimise production of crops. This system consists of sensors and actuators, an Analogue to Digital Converter (ADC) and a Raspberry Pi. The system will determine whether a defined threshold is passed by any climate parameter and systematically changes via the controller. The current work reduces human input through automated irrigation to optimally utilize a scarce resource, namely water. Climatic parameters for plant growth such as, moisture, humidity, temperature, water pressure in drip pipe, soil salinity etc. are monitored and optimized. Furthermore, work was extended to include GSM to control the entire farm remotely. For its success, it is very important to choose a greenhouse location. For instance, the problems are quite different when choosing an adjoining greenhouse, for instance a sunroom or greenhouse. The greenhouse location should be chosen for sunlight, proximity to power and water sources, wind, drain and freeze pockets, and the proximity of the garden and house. The intention behind accomplishment and devise of GSM based Fertigation System is to construct and evaluate the requirement of water in the yield as farming is the major resource of production which habitually depends on the water accessibility. Irrigation of water is usually done by manual method. To ease the work of the farmer GSM based automatic Fertigation (includes chemigation too) system can be implemented so that water wastage can be reduced and also the fertilizer can be added accordingly. Also the Soil Salinity can be checked and reduced if exceeds certain limit. By using GSM, only GSM command via GSM mobile can control the start and stop action of a motor that feeds the field with the water. GSM is used for controlling the entire process and the entire system backbone. It can be used from any distance to control irrigation. The results are assessed by electronic simulator PROTEUS using the desired optimised parameters, the design of this automated greenhouse system with PIC controller. As the inputs to the microcontroller and as an LCD screen record the respective outputs, the model produces a soil moisture sensor, light sensor and temperature sensor. The system

performance is accurate and repeatable for measuring and controlling the four parameters that are crucial for plant growth - temperature, humidity, soil moisture and light intensity. With the reduction in electricity consumption, maintenance and complexity, and a flexible and precise environment control form for agriculture, the new system successfully cured quite a couple of defects in existing systems. Nano composite film sensors (Graphene and Graphene mixed in order to optimise the input of fertilisers for chemical composition determination. Using nano technology in agriculture enforces the firm bond between the engineer and farmer. Nano material film-based gas sensors were used to measure the presence of oxygen and CO<sub>2</sub>.using graphene nano composite sensors integrated into an embedded system, to detect the presence and levels of gases. Improve crop growth with combined red and blue light for lighting under the leavened and solar-powered LED lighting modules. This was achieved by graph/solar cells. The light was measured at the photosynthesis flux (PPFD) of 165  $\mu\text{mol m}^{-2} \text{s}^{-1}$  by 10 cm of its LED module. LED lights were provided between 4:00 a.m. and 4:00 p.m. in the daytime treatments and night treatments from 10 to 10 hours. The use of the nighttime interlumination of LEDs was also economical than the interlumination of charts. Thus, nightlighting LEDs can effectively improve plant growth and output with less energy than the summer and winter times. Solar panels are best functioning during times of strong sunlight today, but begin to wane when they become too hot and cloudy. By allowing Solar Panels to produce electricity during harsh weather conditions and increase efficiency, a breakthrough in graphene-based solar panels can change everything. Ultimately with a fully autonomous system, agricultural productivity and efficiency, the length of the growing season, energy consumption and water consumption were recorded and monitored by exporting the data over GSM environment. With the steady decrease in the cost of high-performing hardware and software, the increased acceptance of self-employed farming systems, and the emerging agricultural system industry, the results will be reliable control systems covering various aspects of quality and production quantity.

**Keywords:** Nano sensors, Grapheme material based Solar cells LED, supplemental lighting, lighting period, photosynthesis, yield, Fertigation, Chemigation

## **1. Introduction to automated Irrigation**

### **1.1 Basic concepts of automation**

A device containing inbuilt program that performs governing or controlling a flow of water from one zone to another zone absence of the irrigator [1, 2].

Mechanization can be utilized in various manners:

- to start and stop irrigation through fluid channel outlets,
- to start and stop tube,
- to remove the progression of water from one water system zone – either a straight or a segment of channel and guiding the water to another zone.

This improvement provides without any direct manual effort, but the irrigator may need to spend time preparing the system at the start of the irrigation and maintaining the components, so it works properly.

### *1.1.1 Merits and demerits of automatic irrigation*

#### Merits:

**Reduced labour:** As a water supply is not necessary to continuously screen the progress of a water system, the water supply system is available to carry out various tasks on an ongoing basis.

**Improved lifestyle:** The irrigator is not necessary for the water to be dampened uniformly downward. The irrigator can stay away from the assets and sleep all night long with the family.

**Faster irrigation:** robotic irrigators prefer to irrigate if water is needed by the plants, not when it suits the irrigation system.

**Helps with higher flow rates:** Many irrigators aim to increase the watering rate by installing higher channels and narrow outlets. Such flow rates usually require more work as a bay's time to water is reduced and therefore more and more change is required. Robotization admits to be handled without an increase in the number of work for this higher procedure.

**More precise cut-off:** The water system automation allows water cut-off at the exact narrow point. Ultimately, this is more accurate than manual inspections, since there may be errors if the operator's water flow changes too late or too early.

**Reduced water and nutrient overflow:** automation can help maintain fertiliser on farm by reducing efficiency in landfill. The retention of fertiliser on farm benefits both economically and environmentally [3].

#### Demerits:

**Cost:** There are costs in buying, installing, and maintaining automatic equipment.

**Reliability:** Can the irrigator trust a programmed framework to work accurately unfaithfully? Now and again disappointments will happen. Frequently these disappointments are a direct result of human blunder in setting and keeping up the frameworks. A re-use framework is acceptable protection to gather any overabundance spillover when disappointments happen.

**Development of channel preservation:** There is a need to expand upkeep of channels and hardware to guarantee the framework works accurately. Channels ought to be fenced to shield the programmed units from stock harm.

## **1.2 Automated watering systems types available**

**Air system: Pneumatic:** A pneumatic frame, initiated by a narrow sensor at the cut-off point, is an unchangeable framework. The air channelled to the instrument for opening and shutting water system structures is then pressurised when water enters the sensor [4].

**Compact system of timers:** A multi-faceted clock frame is an impermanent system that uses electronic tickers to open and shut down the water system structures. Due to its compact nature, property owners usually purchase 4 or 5 units to move around.

**Hybrid based timer/sensor:** This is a crossbred of compact clock and sensor frames, as the name suggests. It uses an electronic gadget to open and shut off structures for the water system, like a convenient clock. This frame has in any event an additional component of the river, which can be used to direct a moveable sensor down that transmits radio signals to the clock gadgets at the outlets for opening or closing the structures when it interacts with water, and sends a radio message to the collector saying that the landlord has come to the chopped water centres.

**SCADA:** the Supervisory Control and Data Acquisition (SCADA) use robotic frameworks consist of a PC and a programme bundle with timing and controlling

a radio system for water. Signs from the PC are sent to the enclosure to control the water system structures with straight actuators and open and close them. Straights are opened and shut down on a premise; a few frameworks can naturally change the time when the channel is in conflict when a sound outlet is opened. The extra advantage of SCADA-based frames is that they are able to start and stop water pumps and motors.

### *1.2.1 System selection*

All mechanisation structures have focal points and burdens to be viewed as to what framework is appropriate for a particular property to the water system format. No framework is the best for all properties. There is no framework.

The methods used by the irrigator for the water system should be considered. Should a framework be required which is able to move around the property and possibly used on various properties, the irrigator must consider the versatile frameworks in this case. If the irrigator requires a frame where the components are fixed and a similar water system can be used which group each water system, a fixed framework would gradually be appropriate in such a case.

The irrigator should consider the expenses of the frame when deciding the best framework for an estate, make sure the framework is adjusted and which framework is most appropriate to the property and the water system [4].

The objectives to consider are:

1. Disentangle the water system framework by introducing and structuring the entire water system framework.
2. Spare vitality which permits the use of savvy water system framework.
3. Advance water utilization.
4. Mechanized framework completely.
5. Decrease the intercession of human.
6. Make framework simple to use by ranchers.

### *1.2.2 History of automated irrigation*

By definition, the water system is the function that water dries through tubes, which contribute to the cultivation of the plant and plants. In your own yard, it's easy to honour and the aerosol you run. After having a settled grass spray system, you won't have to return to your own pants. Attentive experts are guaranteed the repair and installation of water systems that satisfy your requirements and accreditation by aerosol or sprayer [5].

It produced widespread interest during the 19th century when European Americans flooded the drought-prone plains. A water system was practised when a moat was brought to gardens, lawns and trees by a particular area in the 1870's called Fort Sidney. Until 1890, when a drought began, public opinion for the water system was not as conducive then to irrigation. This strengthening of irrigation began to increase every day; there were conventions and legislation was even proposed in the United States. But a while later, Farmers soon appeared to be irrigated by the floods. Sodium and calcium carbonates were rapidly transferred in the land, which makes it too salty for the development of convent plants [6].

The 1930s, also known as the Dirty Thirties, were an era of inflexibility and cultivation of poor humidity in the region, which generated soil arid habitually. Farmers moved quickly to irrigation. The achievement of sprayer systems throughout Canada has been enhanced by modern technologies. Flood irrigation is still used; however, it is no longer responsible for tending crops, normally used only in the sugar industry. It has no responsibility. Pipes and sprayer systems are new and more modern uses of the water system [6].

Turf Rain Irrigation Systems provides over 24 years to the region of South Ontario including Toronto, Mississauga, Oakville, Milton, Burlington, Brampton and neighbouring GTA. We are specialist in pond sprayers, water systems, residential, business, industrial and golf landscape lighting. They also maintain the rehabilitation and maintenance of irrigation systems [5].

### *1.2.3 Mechanized water system using solar power in Bangladesh*

The gadget specializes in rice fields in nations depending on agriculture within the economy, such as Bangladesh. The primary concept in this gadget is to cognize on the level of water in agricultural fields because those fields lose lots of their merchandise due to floods. The sensor sends a message from the field to the person approximately the extent of water within the area if it will increase or decrease then the operator controls the pump to regulate or flip off the telephone. The blessings of this machine are that it depends on the sun energy to get hold of electricity. The dangers of this system are that it centered on one sort of sensor, the water stage sensor, no matter whether the plant desires water or not. There may be no opportunity source of energy in case there is no solar electricity to run the device.

### *1.2.4 Construction and implementation of a mechanized water system in Nigeria*

In this machine the basic idea is to rely on the type of soil and the amount of water needed by each type of soil. This process is done by measuring the level of moisture in each type and using the pump to supply water. The result indicates that sandy soil requires less water than clay soils. The consents of this device are to focus on soil moisture and water conservation. But making the machine much less powerful is to measure the moisture of soil from one location in the agricultural land. It is far viable that the vegetation at the other end of the rural land does no longer need watering. Also, the water source is not constant.

### *1.2.5 Solar water system*

In many of the development projects, the admission of solar pumps to drylands like Africa, India and South America also shows the increase in the ability of local farmers to improve their living conditions. One of the good examples of this is that the scientists developed two solar pumps to support Wedel SET GmbH in an attempt to teach physics at a Blankenese School in Germany. These underground water pumping systems have been installed on two farms in Nicaragua. In addition the UNAN University in León, who worked hard to harness solar energy, was able to achieve this project. This project has been in operation since over 10 years and in Nicaragua now there are 30 pumps. The Nicaraguan company Enicalsa is under the supervision of farmers who benefit from the solar water system. Using solar pumps, even in dry seasons, solar pumps can generate year-round, thus increasing their revenues and reinforcing their local market conditions [7].

In addition, there is an increase in interest in European solar water systems beyond the already noticed regions. The production phase from Austria reached



a few months ago a mobile solar drip water system. This project was carried out by the Austrian company Wien Energie with a dual goal: To reduce CO<sub>2</sub> radiation, on one hand, using solar power, and to achieve 30 per cent water savings compared to conventional water sprinklers with the dripper irrigation method, on the other hand.

It is quite simple to assume the drip water system method. With different brakes, tubes and pipes the water slowly and at normal intervals is drained into the roots of the plants. There is no wasted water, because water is legally sprayed in the air, or leaked into soils where plants do not grow, unlike a spraying system. The dripping water system method therefore allows more crops to grow with less water, making it a highly productive water system process.

Wien Energy solar water systems are connected to a wheel pump that can power and connect to a smartphone application and can determine the energy generated by the system. The mobile photovoltaic system with up to 3kw is combined with a wheelable pump. The solar pump then allowed the water directly to the plants via the tubing. This system is now ready to be produced following a thorough test of 3.5 hectares of organic maize in Guntramsdorf, Austria [8].

Thus, the drinking water system can contribute to efficient water management in countries with high temperatures and insufficient water resources. This is important because farmers are faced with three challenges: water, money and energy savings. Mobile solar drip water systems are the perfect answer to these problems. While these systems are costly and complicated to resolve, many research and development projects aim to make the use of sun power democratic in agriculture, which in future can play a vital role in the management of food and energy crises. (and even now).

A system with an RFID-based wireless sensor network is proposed in this article [9] by the author. Within this system, the author sets moisture on the ground at different places in the field, i.e. farm or farm. Now the sensor transmits data at 2.45 GHz to ZigBee. Now the sensor sends these data to the base plant, and when the soil is dry then only this part of the field is fed by the pump plant [10].

The smart irrigation system based MQTT protocol is produced by Ravi Kishore Kodali and.al. The moisture sensors, soil sensor and water pump are used by Esp8266 Node MCU-12E. This system is used to transfer the data between Esp8266 NodeMCU-12E and the sensor by using the QueueTelemetry Transport Protocol (MQTT) Message system. Soil moisture transmits data to Esp8266 MCU-12E Node and, if the soil is dry, Esp8266 NodeMCU-12E is sent instructions to pump water and to pump the water. They display the actual soil and water pump status using LCDs. Sneha Angal constructs an office and home planting system. This system is equipped with a sensor for raspberry, Arduino, ZigBee and soil humidity. The main control block is in the proposed raspberry pi system. The instructions sent from Arduino are processed. The sensor of moisture is attached to Arduino and ZigBee is a middle between Arduino and raspberry pi. This system is modular, so if any module does not work, the user can modify it. To improve this system, the GSM module can be added to achieve soil status and watering plant by miscalculating the number of the GSM module [10].

Mare Srbinovska et.al developed a smart, vegetable greenhouse wireless sensor network. Humidity, temperature and lighting are being measured in this system. The first steps of this system are to measure the data transfer capacity and select the data exchange algorithm. The second phase of the system proposed determines the design and development of the system based on experimental findings. The last step is to test, analyse and optimise the wireless sensor network.

They focus in this paper [8] on very important agricultural products issues. They created a system to detect tomato disease. They made a robot to continuously shoot

a plant. Now they have produced a video processing algorithm afterwards. The first phase focuses heavily on the classification of the tomato plant, while the second is the recognition of diseases at the border of tomatoes. They use the k-mean clustering algorithm to identify diseases.

Lala Bhaskar et.al are constructing a system to increase food quality and productivity. Different factors such as temperature, humidity, water level of the ground and LCD are measured by this system. In order to inform farmers of the current status via the SIM900 module about the registered number, the data is monitored and sent to farmer with the message. Sensors such as soil moisture sensor and temperature sensor are used. This system is helpful for farmers with a power failure and uniform water distribution due to electricity failure.

This paper [11] aimed to build a cheap system because it can be used by an anonymous farmer, and a step towards intelligent agriculture. Raspberry-pi, soil humidity sensor and GSM module were used in this system. If soil humidity is sensed as dry soil, the farmer will be notified and mailed to the registered email address. Local Shortest Path (LSP) was used by the proposed system author in order to control the wireless sensor network, i.e. to obtain data from the sensor via LSP.

They proposed a system to improve the agriculture method, to measure the PH rate to detect dryness of the soil and also to keep an eye on temperature and water level. The pi, LCD, and soil humidity sensors were used to show current status and GSM module. Now that a certain threshold value decreases the PH rate, it notifies the user of improving the method of agriculture and proposes to farmers based on the PH value. They used LM35 for soil temperature measurement. They continue to collect data in this system to find water levels to enhance the system by watering the ground on a water level basis.

Ch Sumaliya et.al suggested a low cost system. The controller, soil moisture sensor and temperature sensor ATMEGA328 was used in this system. The data was displayed in LCD using a raspberries pi and ZigBee recipient. Now, if soil moisture falls from a particular limit value, the buzzer will be littered and the state on LCD is displayed. When the threshold moisture increases, they start the motor and the buzzer disappears. They don't use Wi-Fi in this system so that we can build a Wi-Fi system. The temperature sensor can also be added and instructed on the motor for measuring the temperature.

The focus of this article [6] was a saving water by means of an intelligent irrigation system. They focus primarily on gardens, plants and parks to automatically supply water. And water supply based on requirements requires additional water and some require less water. They use a microcontroller to ensure the requirements and obtain data from the sensor of soil moisture and temperature. If the water level is low, plants can receive water to improve this system.

Bin Bahrudin, Md Saifudaulah and.al proposed stayed for fire. The raspberry pi, Arduino Uno and the smokesensor, camera module and the GSM module have been used on this system. The system clicked a photo and shows it on the website when smoke is detected. It now requires users to confirm that there is or is not a fire. In the event of a fire, the fire task force sends SMS. This system is now used to reduce the amount of storage needed to store image to counterfeit because the camera clicks on the photo.

In this paper [12] authors developed a system for intelligent irrigation and weather surveillance. To this end, they take into account certain parameters such as soil humidity, humidity, temperature, rainfall, and wind direction. They measured soil humidity to detect soil dryness and rain sensor soil evaporation. So, if the moisture level of the soil falls from the user value, the watering starts. For mapping wind speed, a device called anemometer. This data is uploaded to the server and shows the data on the LCD.

## **2. Introduction to nano sensors**

The nano sensors are nano sensors that calculate and switch physical quantities to identify and inspect the signals. Nano sensors Today we have a number of approaches for the production of nano-sensors: top-down lithography, bottom-up and molecular self-montage. A variety of nano sensors, particularly in the defence, ecological and healthcare sectors, is available on the market. The same primary workflow is distributed by these sensors: a permanent selective analyser, signal generation from the nanosensor relationship to its bioelement and signal generation in useful metrics [13].

Nanomaterial sensors differ from sensors made from traditional materials because they do not appear in a mass material occurring on the nano-scale, so they have different sensitivities and specificities. Nano sensors operate on the same scale as natural biological processes, allowing for noticeable physical changes with chemical and biological molecular functionality. Sensitivity amplification is caused by the high ratio between the surface and volume of the nanoparticles and the physical narrational properties of nanomaterials, including nanophotonics, that can be used to detect them. Nano sensors are used to add fundamental processing capabilities for the nano sensor together with nanoelectronics [13].

In addition of sensitivity and particularity to the nano sensors, it offers a valid advantage in cost and time response, its accomplishing for high-throughput applications [14]. Nano sensors accommodate real-time monitoring compared to traditional detection methods such as chromatography and spectroscopy. The traditional methods may take more to access the results and often lack of asset in capital costs together with time for sample preparation.

One-dimensional nano materials like nano wire, nano tube are well suited for use of nano sensors, in comparison with bulk or thin –film planner devices. That can be worked as transducers and wires to transmit the signal. Their high surface area can cause large signal changes upon binding of an analyte Their small size can enable large scale multiplexing of severally capable of addressing sensor units in a small device, their operation is also “label free”, is not essential fluorescent or radioactive labels on the analytes. Zinc oxide nanowire is employed for gas sensing applications, given that it demonstrates high sensitivity towards low concentration of gas beneath ambient conditions and can be manufactured easily with low cost.

By avoiding drift and fouling, developing reproducible position methods, applying pre concentration and departure methods to get a proper analyte combination that avoids overload, and accommodate the nano sensor with other sensor elements package in a stable manufacturable manner. After all nano sensors are almost new technology, there are lot of unanswered questions related to nanotoxicology, which presently permits their application in biological systems.

Possible nano sensor applications include medicine, contamination and pathogens detection and monitoring of production and transport systems. At the molecular level, nanosensors can differentiate between certain cells and can either carry out medicines or monitor their development of individual body locations by calibrating physical properties change (volume, concentration, displacement and velocity, force, electrical and magnetic forces, pressure and temperature). The signal transduction type defines the main nano-sensor allocation system. Various types of read outs for a nano-sensor include optical, electromagnetic, mechanical or vibrational. Nanosensors that use molecular imprinted polymers (MIP) can be divided into 3 classes of electrochemical, piezoelectric or spectroscopic sensors as an example of categorization. Electrochemical sensors induce a change in sensing material’s electrochemical properties including charging, conductivity, and electrical potential. Piezoelectric sensors convert mechanical energy into electrical



strength or vice versa. Then this force is transferred to a signal. MIP spectroscopic sensors, such as chemical light, surface plasmon resonance and fluorescence sensors, can also be divided into three sub-categories. These sensors produce light-based signals in the forms of chemical light, resonance and fluorescence, as their name suggests [13].

## 2.1 Embedded system design with nano interpretation

The following **Figure 1** shows the simple drip irrigation model and **Figure 2** describes the corresponding embedded transformation.

The structure is an embedded system that regularly examines and controls the microclimatic parameter of a field for crop or species of specific plants, allowing production to maximise in the entire crop season and removing difficulty. The main purpose of this system is to improve and respond effectively and reduce human interference, which also increases levels of protection. It includes sensors, microcontrollers, analogue to digital converters and actuators. When any climate parameter crossing a security threshold to protect the crops is kept, the sensors feel changes. After converting the ADC to a digital form it is read on the data from the input ports by the microcontroller. The microcontroller takes action by using relays up to the optimum level of the stretched out parameter. As the core of the system is a microcontroller, the setup is low cost and yet efficient. The entire setup is affable because the system also uses an LCD display for constantly alerting the user of the circumstances in the field [9].

The irrigation system requires approximately half of a sprinkler or surface irrigation system's amount of water. Lower operating pressures and flow rates lead to lower energy loads. You can achieve a higher degree of water management [15]. More exact amounts of water may be provided for plants. The damage to insects and diseases is reduced by keeping leafy plants dry. Investments generally decrease in

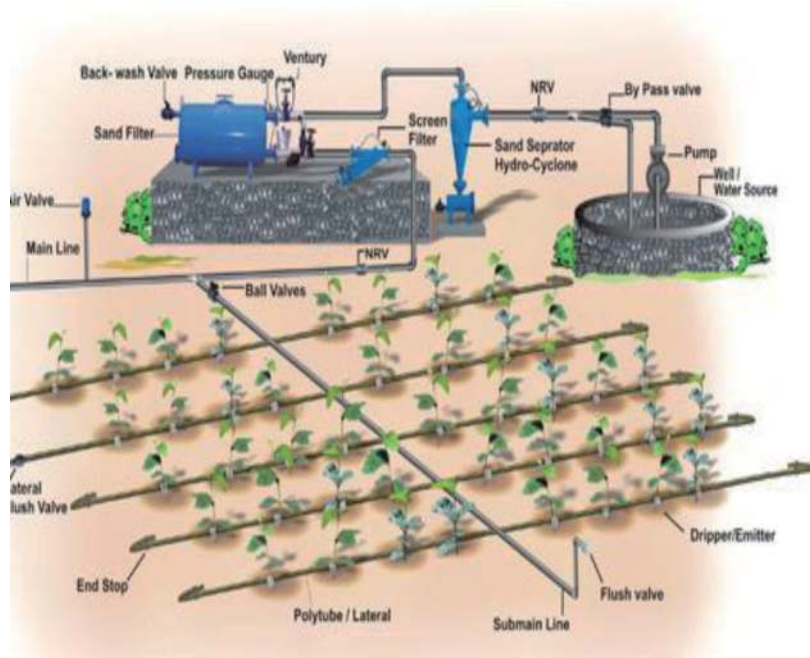

**Figure 1.**  
*Simple Drip irrigation Model.*

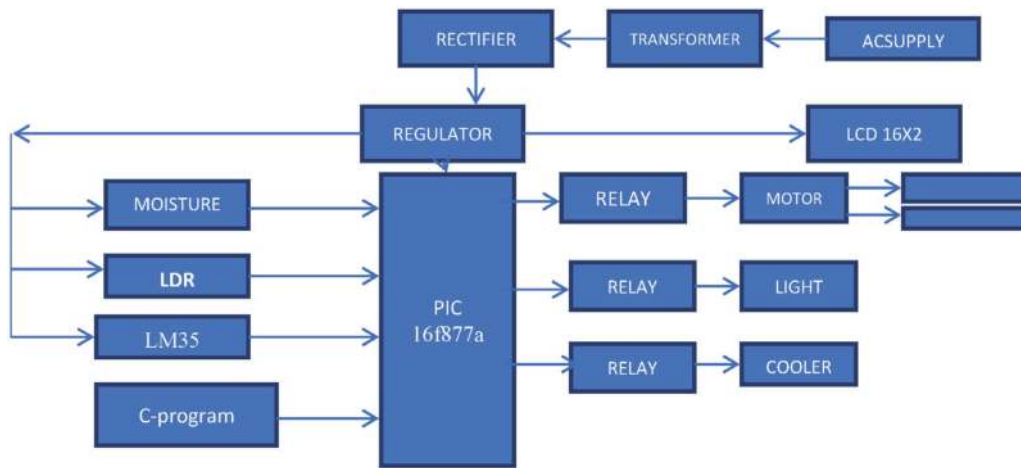

**Figure 2.**  
*Embedded System Transformation.*

operating activities. Due to dryness of rows between plants, the process can continue during irrigation [16].

A drip irrigation system may be used under a wide range of field conditions. A typical drip irrigation system is displayed [10]. Drip irrigation is trendy, as it can increase yields and reduce requirements for water and labour.

This type of system can apply manures. This can lead to lower dung and costs. Drip watering results in less soil and a wind erosion if it differentiates with overhead sprinklers [17].

## 2.2 Smart irrigation using Raspberry PI and GSM

With the Raspberry pi, GSM module, soil humidity sensor, flame detector, ultra-sonic sensor, and buzzer, the above embedded system could be changed. The Raspberry Pi is only a computer and has a very powerful, lightweight ARM processor. It also has USB ports, WiFi modules, HDMI port and Ethernet port, Raspberry Pi 3 Model B. OSes such as Raspbian, Ubuntu MATE, Snappy Ubuntu, Pidora, Linutop, SARPi, Arch Linux ARM, Gentoo Linux, freeBSd, KaliLinux and RISC OS Pi are also available for Raspberry Pi [18, 19].

It has multimedia application support as a small computer. The reason is HDMI and the support for graphics. But it does also have some limitation, but we can insert a micro SD card, so we can boot the Raspberry Pi OS. But there are no limitations.

We use a raspberry pi, soil moisture sensor, a flame sensor, an ultrasound sensor, a buzzer and a servo engine in this system. The heart of the system is the raspberry pi, i.e. the main system control unit. We used raspberry pi b+, which has many new characteristics in this system. It has also improved IO connectivity compared to the older pi version. Soil humidity is connected directly with raspberry pi. Now when the sensing data is transferred, the data is transferred to raspberry pi [20]. Raspberry pi reacts according to the soil humidity sensor received data. If soil is dry, send an email to the mobile number and email address registered with the farmer and the motor start. The detection of fire in a farm is used to detect fire. The fire sensor collects data from the field and passes it on to the pi. If fire is on, we will now send a message to the farmers' registered mobile telephone and e-mail address. We simultaneously blow up the buzzer. We measure water level well with an ultra-sonic sensor. We will now take the depth and radius of the well of farmers to

measure water levels in a good way. Now we can measure the current water level in the well by using an ultrasonic sensor and calculate the water level from the bottom of the well. We will subsequently send it to the registered mobile and email address of the farmer [10].



**Figure 3.**  
*Raspberry pi.*

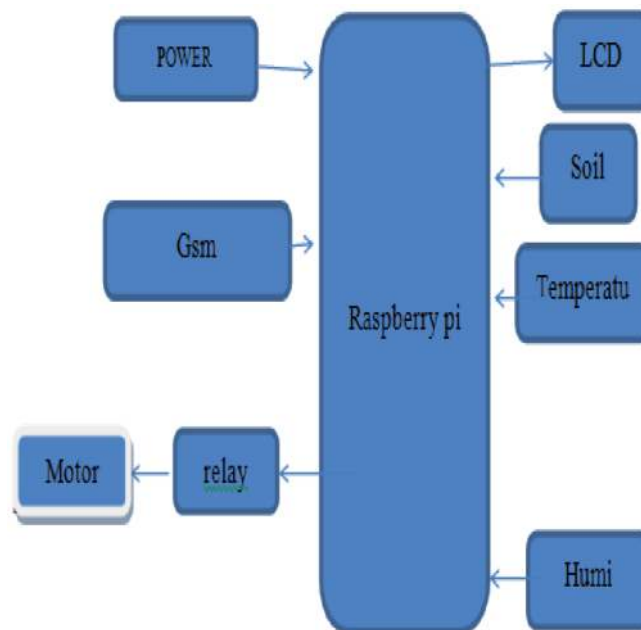

**Figure 4.**  
*Smart Irrigation with Raspberry Pi and GSM.*

Film-based nanomaterial enhanced polymer sensors (Graphene and Graphene mixed to form a definite chemical soil structure for improved input manure. Thus, through these systems, we can boost the returns of our farm products and, therefore, the economy of our nations. Moreover, by establishing strong links between farmers and farmers, these systems make agriculture simple and inhibit the transformation of the agricultural land to residential areas [9]. The presence of oxygen and CO<sub>2</sub> was measured by nano material film-based gas sensors. The presence of gases will be detected and the increase or decrease of graph-enriched polymer films interspersed in an embedded system, especially the gas level in the environment (Figures 3 and 4).

### **3. Interlighting odules**

Power growers to produce exceptional returns of products with attractive characteristics, using industrial plants with sunlight-based light. In winter, when the sole-based elevation and the PPFD overhang are low and day long is smaller than in summer, a crop that is of high planting thickness, low photosynthetic moving thickness (PPFD) in the lower leaves generally is cut off in the plant development. This allows additional lighting to build profitability for the lower shelter throughout the year. Additional lighting can be expensive in any case. In some places the cost of power is lower around the evening, but there is no inspection of the effect of using additional light around the evening [21]. In this study, the effects of additional LEDs between lighting during the day and evening were examined for photosynthesis, development, and yields in both winter and summer between lighting modules with a rounded red and blue light to enlighten the lower leaves directly following the initial proposal [12]. LED was used between lighting modules with a consolidated red and blue light. The LED module was estimated at the PPFD of the light at  $165 \mu\text{molm}^{-2}\text{s}^{-1}$ . Driven between the illumination, daytime between 4:00 am and 4:00 pm and night between 10:00 pm and 10:00 am.

Plants which were clearly represented by sunlight were used as controls. The photosynthetic limit of the centre and the lower leaves between lights expanded with daytime LEDs, which in winter total expanded yield by 27%; however, in the summer photosynthesis limit and yield were not expanded substantially. This methodology allows the yield to be increased by 24% in winter and 12% in summer. What's more, evening LED between lighting in winter essentially expanded the absolute solvent solids and ascorbic corrosive substance of the tomato organic products, by 20 and 25%, separately. The use of LEDs between lighting during the evening was also financially more knowledgeable than between lighting at daytime. This allows LEDs between the lighting in the evening to improve the development of tomato plant and yield, as well as the daytime and summer costs.

The understory leaves were enlightened by the intermediate lights (Philips Green Power LED between DR/B, Philips, Eindhoven, the Netherlands). The light range was red and blue together with a PPFD measured at 10 cm from the LED module, of  $165 \mu\text{mol m}^{-2} \text{s}^{-1}$ , and 40 cm from the Styrofoam board under which the root frame has been built.

#### **3.1 Distribution of light in the plant profile**

At each level of cover (top, centre, and bottom) a quantum sensor estimated the light transmission along the plant profile (LI-190SA; Li-Cor). The sensor was located with the ultimate goal to equivalent the trend edge to the leaves of the agent



protection. LEDs between light estimates were made while LEDs were used between lighting. As control, sun-powered irradiance alone was used and without an LED between lights was estimated.

In winter, light is not standing and influences photosynthesis and production in those lines, as the development of plants and yield generally relies on photosynthesis (Hao and Papadopoulos, 1999). (Yamori, 2013; Yamori and Shikanai, 2016; Yamori et al., 2016). Since the development of one-bracket uses high plant thickness, light for the lower covering blocks is a significant restrictive variable (Lu et al., 2012a). In winter, an attempt at light capture by sun-based light is restricted in both the top and the base shelter leaves, whilst in the summer; the lower overhang leaves are constrained by light due to the thickness of the high plants (Gunnlaugsson and Adalsteinsson, 2006). (Ackerly and Bazzaz, 1995). In all, a 1% decrease in the total daily light throughout the developing season results in a loss of 1% in childcare production (Cockshull et al., 1992).

High planting thickness reduces light spread and the plant profile connected with common concealment (Zhang et al., 2015). The understories of tomatoes are extremely low net photosynthetic rate, due to their lesser light and leaf senescence (Acock et al., 1978; Xu et al., 1997) However, the low transmittal light that results in senescence affected the photosynthetic pace of the understory leaves (Acock et al., 1978). Frantz et al. (2000) suggested the essentially postponement of further light inside cowpea, which cover the inner leaves. Increased lighting from below also prevented external leaves from spreading and expanded the photosynthesis rate, which improved the entire cultivation of lettuce (Zhang et al., 2015).

Between the light, additional high installed lighting can be more attractive (Adams et al. 2002), improving the net photo synthesis of the undercover and then the output (Hovi et al., 2004; Pettersen et al., 2010). More generally, half improves have been achieved in various crops, although certain tests on different plants and areas have demonstrated no increase in yield (Hovi et al. 2004; Hovi and Tahvonon, 2008; Pettersen et al. 2010; Lu et al. 2012a, b) (Gunnlaugsson and Adalsteinsson, 2006; Heuvelink et al., 2006; Trouwborst et al., 2010). In fact, the development of single-substantial tomatoes has increased by 20% in winter between lighting output and by 14% in harvest time. (Second Words, 2012a,b). Some cover can then be useful to illuminate the lower section.

LEDs are seen as a suitable light hotspot between lighting (Hao et al. 2012) on the ground that they produce less warmth and are less likely to consume leaves as contrasting and HPS lights. In the previous decades, the progression of LEDs as an elective lighting source has enabled scientists and rancher to control their phantom characteristics through the consolidation of different light sources with various discharges on wavebands (Goto 2003; Merrill and al. 2016). There has been discussion of efficient plant development phases and light properties between the lighting application (Lu et al., 2012a, b); however, no research has been made into improvements in the lighting time frame with additional lights between winter and summer.

Moreover, the vitality production use of lighting can be accomplished by changing the LEDs between the illumination plans to use it further in the nighttime since the costs per unit kilowatt can be reduced with the off-the-run time of use (TOU). Different companies have recharged their electricity expenses with limited off-top rates (Ashok and Banerjee, 2000; Ashok, 2006; Middelberg et al., 2009). In the creation of nursery crops, farmers are concerned with elective lighting systems, which can produce yield and reduce labour costs. In all events, no analysis has been taken into account of the effect of supplemental evening time between photosynthesis, development and output lighting. In this study, we analysed the impact of LEDs during the day or evening between photosynthesis lighting, the development and yield in winter and summer in a single bracket of tomatoes.



Connected with the red joined blue light between lighting modules to illuminate lower leaves. Graph / Sun-oriented cells could improve this.

Graph-based sunlight-based sunlight cells could be used to improve the skills of sun-based cells and to gain vitality from these sun-based cells. New graph/si Schottky intersectional sun - powered cell with a backrest contact structure that has the advantages of easier production, lower creative costs, and greater dynamic area when examined using a gadget produced with the previous structure. Such sun-powered cell varieties had been delivered and therefore the efficiency is increased.

Sun powered boards work best today in times of strong daylight, but start dying when it gets cloudy or blistering. A forward step in sun powered boards based on Graphen could make a difference by allowing sun-based boards to create power in the disastrous environment. Finally, profitability, vitality collection and water use were retouched by the sending of information about the GSM condition without human intercession. Efficacy will also enhance. Great acres of land can be maintained with less human maintenance and also an enormous increase in efficiency.

#### **4. Energy harvesting module**

Sunlight based vitality is broadly accessible vitality source on the planet. Sun - based force isn't just acceptable by the perspective on the economy yet additionally it is condition well disposed type of the vitality. Presently days this vitality is utilized in road light and in other local burdens. In the present life because of advance innovation's the expense of sunlight based board diminishes, that will assist with utilizing sun based vitality in different segments. One of the uses of sun - powered vitality is in the water system framework. In India there is serious issue of vitality, in this manner sun - powered vitality is best answer for Indian rancher. The consistent extraction of water from earth is resultant into decline in water level from the earth with the goal that part of land comes gradually in the un-flooded zone, another explanation of this is because of impromptu water system. Additionally now-a-day's populace increments quickly so request of food likewise builds which doesn't get balance among request and flexibly of food.

##### **4.1 Concept of smart irrigation**

The old water system techniques are sprinklers and flood type framework. In these strategies, the utilization of water is in enormous sum. On account of inclines in the field a huge measure of water moves downwards. In this manner, the rest of the piece of the field remains un-flooded. Huge measure of water goes squander in these strategies. Such an issue could be overwhelmed by this work which utilizes sensors with microcontroller, subsequently half water sparing is accomplished. Utilization of sun oriented board makes this green method of vitality sparing [22].

As per the study directed by the Bureau of Electrical Energy, in India in 2011 there are around 18 million farming siphon sets and around 0.5 million new associations for every Sardesai Mayur A. Patil Ranjeet G. Patil Ranjit B. Katkar Kiran B. Sutar Rohit R. Dr. IrranaKorachgoan Department of Electrical Engineering, Shivaji University/AMGOI Wathar, Kolhapur, Maharashtra, India, are introduced with normal limit of 5HP. Complete yearly utilization in the horticulture division is 131.96 billion KWh. (19% of all out power utilization) [17].

METHODOLOGY: Proposed water system framework comprises of two sections, sunlight - based siphoning and programmed water system part. Sun based board charges the battery through charge controller. From the battery, flexibly is given to the engine legitimately in this work [17].

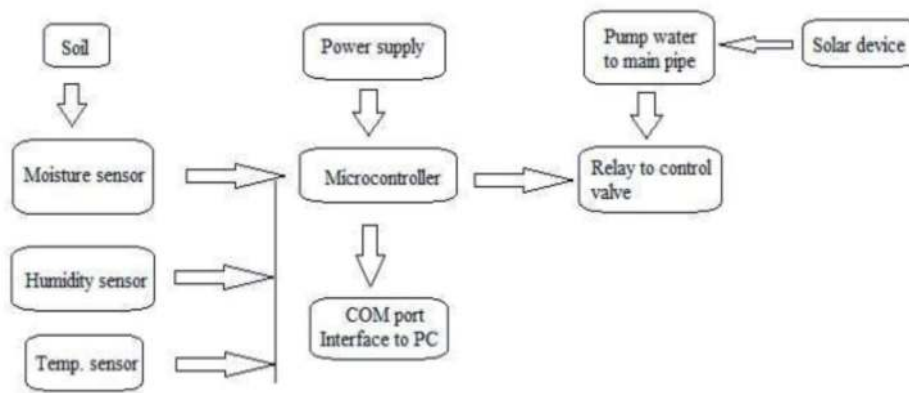

**Figure 5.**  
*Block diagram of solar powered irrigation system.*

**Figure 5** shows the square graph demonstrating the fundamental pieces of sun based fueled water system framework. Here the detecting circuit controls the engine. The sensors utilized are soil dampness sensor, temperature and mugginess sensor. The sensor distinguishes the estimations of soil dampness, temperature and stickiness at various focuses in the field. Microcontroller as indicated by pre-set worth looks at the deliberate qualities. In light of the blunder between the pre-set and estimated values, engine ON/OFF condition is controlled [23].

#### 4.2 Solar irrigation system

The siphons utilized for the vehicle of the water are outfitted with sunlight based cells. The sun- powered vitality consumed by the cells is then changed over into electrical vitality through a generator which at that point takes care of an electric engine driving the siphon. The vast majority of the conventional siphon frameworks for the most part work with a diesel motor or with the nearby force network. In any case, these two methods of tasks present inconveniences contrasted with sunlight based siphons [24].

In numerous country territories, particularly in creating and developing nations, the entrance to the power network isn't constantly ensured. For this situation, ranchers can't depend on the conventional water system framework. Hence, utilizing an autonomous and elective vitality framework can be an answer for the rancher to make sure about a protected force source and for the open lattice to maintain a strategic distance from immersion.

Diesel siphons are somewhat more effective than AC fueled siphons as they permit more prominent adaptability. In any case, one of the fundamental imperatives is that this framework depends on the fuel accessibility, included to a more noteworthy effect the earth. Diesel-driven siphons are less expensive than sun oriented controlled siphons yet the working expenses are very high and rely vigorously upon the diesel cost. In sunlight based controlled frameworks, it works the other path round, that is, in spite of the fact that this framework is moderately costly, the wellspring of vitality is free, accordingly, after the amortization time frame, there are done working costs (just the upkeep costs must be thought of). Accordingly, sun oriented siphons end up being a feasible long haul venture.

As a few investigations, such as Water for riches and food security by AgWater Solutions Project, have appeared, the entrance to water for agrarian purposes stays basic in certain zones, for example, in dry districts of Africa and Southern Asia. Numerous Indian and African ranchers bring the water straightforwardly from

the well or the waterways and inundate their fields utilizing cans. In the event that ranchers of those areas could approach a mechanized siphon, they would increase their yield by 300%.

As a result, R&D is nowadays generally focusing on sun-based syphons which in parched locations are moderate. In collaboration with Siemens, the company IBC SOLAR has created a response to the sun-based diesel engine replacement. The entire water system framework, including the syphon is worth in this situation; only a photovoltaic frame and the so-called IBC syphon control system replace the diesel engine. In 2015, a model was tested and was ultimately extremely effective for this framework from a ranch in Namibia, as the producers had pointed out. The main leeway lies in the way that the current framework utilises low costs of obtaining. The controller consists of 10 simple information channels, 6 simple delivery channels, 40 I/O lines, 3 accelerometer implants and WiFi. The advanced and simple data sources are used for the interface with the controls, the soil moisture sensor, the adhesive and temperature sensors and the current rates sensors. The transmission panel is used to interface the syphon and a saphon that controls the process of the water system. The transmission panel operates at 5 V flexible voltage. The 5 V sign is supplied by a buck converter to the transmission board, which sets the 12 V of the load controller down to the ideal 5 V voltage.

A model has been structured and tested. The upper part is a rectangular tub with double layer loaded with soil, while the lower part is loaded with water to imitate the underground water table completely or uncompletely. The plastic layer, which isolates the top and ground layers, has openings which allow water to flow into the bottom layer which has not been consumed by the dirt. A syphon is lowered into a subterranean water table that concentrates and stores water in the water supply (water stockpiling tank). The bilge syphon channel has a channel that is not sucked into the syphon by broken soil or by any other particular material. This general structure is designed to emulate ranches which can approach ground water but can access almost zero water sources. In the process of the dribble water system described in **Figure 7**, a stomach syphon separates the water from the tank and is responsible for flooding the household. The water rate can be controlled through the stomach syphon, which controls the water rate by irrigation dribble [25].

### **4.3 Renewable energy requirement calculation**

This segment presents the computations required to evaluate the force expected to work the proposed keen water system framework. As referenced before, for this model ranch plan, it is accepted that the homestead will have 5.5 h of steady splendid daylight daily, i.e. HSD = 5.5 h.

It is additionally accepted that solitary 80% of this 5.5-h range produces useable force, i.e.  $\eta_{\text{usable}} = 0.8$ . Note that the numbers for HSD and  $\eta_{\text{usable}}$  are not picked totally discretionarily. This can be seen by playing out the accompanying calculation. Think about that as a day has 12 h of daylight (paying little heed to splendor), and afterward figure the proportion  $(5.5 \times 0.8)/12 = 36.67\%$ .

This shows regardless of whether a sun based board is set out in the sun for the whole day, just about 37% of the hours of the whole day add to useable electrical vitality, which might be a traditionalist figure giving the condition of at present proceeding with mechanical headways identified with sunlight based boards, and thus the above suppositions appear to be sensible.

The accompanying figuring's give subtleties identified with the choice of the battery required for the proposed model of the brilliant water system framework. For a 100 W sun based board, as this rating is bigger than the determined 98.6 W

rating. It is worth to take note of that the force determined is the force required for the one-day activity, and not prompt force required.

The everyday vitality required to be provided/put away by the battery Edbatt can be figured as the proportion the vitality required every day separated by the battery proficiency,

$$Edbatt = Edtot/\eta_{batt} = 369/0.8 = 461.25 \text{ Wh/d.}$$

The useable Ampere-hour (Ah) limit of the necessary battery can be determined by partitioning Edbatt by the evaluated terminal voltage of the battery, for example.

$$Cbattday = Edbatt/V_{batt} = 461.25/12 = 38:44 \text{ Ah.}$$

The usable limit required for the battery, to keep up the activity for a day is,  $38.44/0.75 = 51.26 \text{ Ah.}$

The battery should not be completely released as its life span will be shortened; the depth of release will be considered afterwards. If the sonny-light board is short or does not reach daylight for the whole day, the battery is fully charged on the previous day by using a battery with this limit. As mentioned above, a 100 W PV sun-based panel and a deep cycle, lead-corrosive battery with limit of 55 A h, evaluated at 12 V, is to be used as mentioned previously. In view of the fact that its structure makes it possible to charge and release different occasions without having a complete impact on the battery health a profound cycle battery is used [24].

## 5. Data acquisition, processing and recording

### 5.1 Simulation results and validation

The circuit is recreated using the PROTEUS system for electronic testing. This model produces the ground-humidity sensor, the light sensor and the temperature sensor as microcontroller feeds and comparative results on the LCD. **Figure 6** shows the sensor of soil humidity detection. In this structure, the ideal soil moisture level is set to 100 volts. The process is started and the motor activated if the voltage level is not exactly the water system limit (100 Volts). When the level exceeds the rim, the engine stops and the control is naturally resolved without human mediation. The engine is not controlled [9].

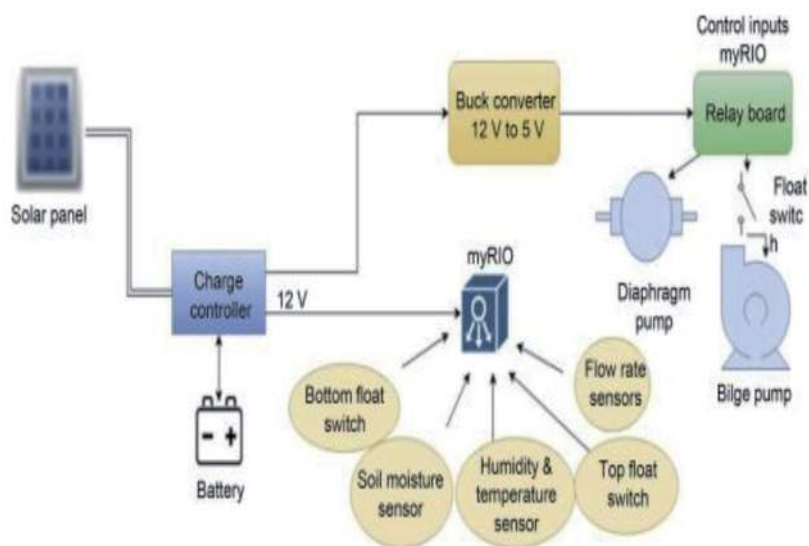

**Figure 6.**  
 Overall system design.



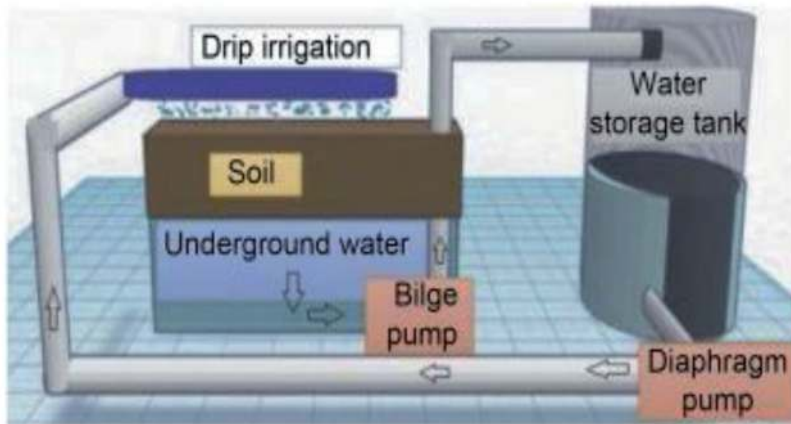

**Figure 7.**  
*Physical layout of the prototype farm and smart irrigation system.*

The controller consists of 10 simple information channels, 6 simple delivery channels, 40 I/O lines, 3 accelerometer implants and WiFi. The advanced and simple data sources are used for the interface with the controls, the soil moisture sensor, the adhesive and temperature sensors and the current rates sensors. The transmission panel is used to interface the syphon and a saphon that controls the process of the water system. The transmission panel operates at 5 V flexible voltage. A buck converter is given to this 5 V sign to the Transfer Board, which descends the 12 V voltage flexibly from the load controller to the ideal 5 V level.

A model has been structured and tested. The upper part is a rectangular tub with double layer loaded with soil, while the lower part is loaded with water to imitate the underground water table completely or uncompletely. The plastic layer, which isolates the top and ground layers, has openings which allow water to flow into the bottom layer which has not been consumed by the dirt. A syphon is lowered into a subterranean water table that concentrates and stores water in the water supply (water stockpiling tank). The bilge syphon channel has a channel that is not sucked into the syphon by broken soil or by any other particulary material. This general structure is designed to emulate ranches which can approach ground water but can access almost zero water sources. In the process of the dribble water system described in **Figure 7**, a stomach syphon separates the water from the tank and is responsible for flooding the household. The water rate can be controlled through the stomach syphon, which controls the water rate by irrigation dribble.

## 5.2 Renewable energy requirement calculation

This segment presents the computations required to evaluate the force expected to work the proposed keen water system framework. As referenced before, for this model ranch plan, it is accepted that the homestead will have 5.5 h of steady splendid daylight daily, i.e. HSD = 5.5 h.

It is additionally accepted that solitary 80% of this 5.5-h range produces useable force, i.e.  $\eta_{\text{usable}} = 0.8$ . Note that the numbers for HSD and  $\eta_{\text{usable}}$  are not picked totally discretionarily. This can be seen by playing out the accompanying calculation. Think about that as a day has 12 h of daylight (paying little heed to splendor), and afterward figure the proportion  $(5.5 \times 0.8)/12 = 36.67\%$ .

This shows regardless of whether a sun based board is set out in the sun for the whole day, just about 37% of the hours of the whole day add to useable electrical vitality, which might be a traditionalist figure giving the condition of at present



proceeding with mechanical headways identified with sunlight based boards, and thus the above suppositions appear to be sensible.

The accompanying figuring's give subtleties identified with the choice of the battery required for the proposed model of the brilliant water system framework. For a 100 W sun based board, as this rating is bigger than the determined 98.6 W rating. It is worth to take note of that the force determined is the force required for the one-day activity, and not prompt force required.

The everyday vitality required to be provided/put away by the battery Edbatt can be figured as the proportion of the vitality required every day separated by the battery proficiency,

$$Edbatt = Ed_{tot}/\eta_{batt} = 369/0.8 = 461.25 \text{ Wh/d.}$$

The useable Ampere-hour (Ah) limit of the necessary battery can be determined by partitioning Edbatt by the evaluated terminal voltage of the battery, for example.

$$Cbatt_{day} = Edbatt/V_{batt} = 461.25/12 = 38.44 \text{ Ah.}$$

The usable limit required for the battery, to keep up the activity for a day is,  $38.44/0.75 = 51.26 \text{ Ah}$ .

The battery ought not to be released totally since it will abbreviate its life expectancy; subsequently, the insight of release is thought about [23, 24]. Utilizing a battery of this limit resolve the framework for a whole day if the sunlight based board comes up short or doesn't get daylight for the entire day, accepting the battery was charged to the full limit on the previous day [15]. As indicated by the above estimations, it is chosen to utilize a 100 W PV sun based board as referenced previously, and a profound cycle, lead-corrosive battery of the limit of 55 A h evaluated at 12 V. A profound cycle battery is utilized, in light of the fact that its structure empowers it to be charged and released various occasions without altogether influencing the general battery health [21].

## Author details

Arasu Sivagami<sup>1\*</sup>, Michael Angelo Kandavalli<sup>2</sup> and Bhaskarrao Yakkala<sup>1</sup>

<sup>1</sup> Department of NEMS, Institute of ECE, Saveetha School of Engineering, SIMATS, Chennai, Tamilnadu, India

<sup>2</sup> Department of ECE, Dhanekula Institute of Engineering and Technology, Vijayawada, Andhra Pradesh, India

\*Address all correspondence to: [sivagamiarasu.sse@saveetha.com](mailto:sivagamiarasu.sse@saveetha.com)

## IntechOpen

© 2021 The Author(s). Licensee IntechOpen. This chapter is distributed under the terms of the Creative Commons Attribution License (<http://creativecommons.org/licenses/by/3.0>), which permits unrestricted use, distribution, and reproduction in any medium, provided the original work is properly cited. 

## References

- [1] E.Sowmiya, S.Sivaranjani Smart System Monitoring on Soil Using Internet of Things (IOT) International Research Journal of Engineering and Technology (IRJET), Volume: 04 Issue: 02 Feb (2017)
- [2] A.Sivagami,U.Hareeshvare, S.Maheshwar,Dr.V.S.K.Venkatachalapathy, “Automated Irrigation System for Greenhouse Monitoring”, in Journal. 2 of Institution of Engineers (India): Series A, <https://doi.org/10.1007/s40030-018-0264-0018>
- [3] Ch Sumaliya, C Bharatender Rao “Smart Farm Monitoring Using Raspberry Pi and Arduino”, International Journal of Management Studies (IJMS), Volume: 01 Issue: 11 | Nov (2016)
- [4] M. Srbinovska, C. Gavrovski, V. Dimcev, A. Krkoleva, V. Borozan, “Environmental parameters monitoring in precision agriculture using wireless sensor networks” J. Clean. Prod., 88(2015), pp. 297-307
- [5] [www.youtube.com](http://www.youtube.com)
- [6] S. Darshna, T.Sangavi,Sheena Mohan, A.Soundharya, Sukanya Desikan “Smart irrigationSystem” IOSR Journal of Electronics and Communication Engineering (IOSR-JECE) , Volume 10, Issue 3, Ver. II May -Jun.2015
- [7] Sneha Angal, “Raspberry pi and Arduino Based Automated Irrigation System” Department of Electronics & telecommunication, Dhole Patil College of Engineering, Pune, India
- [8] Sudhir Rao Rupanagudi, Ranjani B. S., Prathik Nagaraj, Varsha G Bhat, and Thippeswamy G, “A Novel Cloud Computing based Smart Farming System for Early Detection of Borer Insects in Tomatoes,” ICCICT, pp.1-6, 2015
- [9] Zulkifli, C. Z.\* and Noor, N. N. “Wireless Sensor Network and Internet of Things (IoT) Solution in Agriculture” *Pertanika J. Sci. & Technol.* 25 (1): 91 - 100 (2017)
- [10] Prabhu, Boselin and Pradeep, M. and Gajendran, E., “An Analysis of Smart Irrigation System Using Wireless Sensor Network” *Star Vol.5 Issue 3(3)*, March (2017)
- [11] Chandan Kumar, pramiteebehera “A Low Cost Smart Irrigation Control System”, International Conference on Electronics and Communication System (ICECS 2015) IEEE 1146
- [12] Pranita A. Bhosale, Prof. V. V. Dixit, Water Saving-Irrigation Automatic Agricultural Controller, International Journal of Scientific & Technology Research volume 1, Issue 11,December 2012
- [13] Lala Bhaskar, BarkhaKoli, Punit Kumar, Vivek Gaur, “Automatic Crop Irrigation System” IEEE (2015).
- [14] Ravi Kishore Kodali, Borade Samar Sarjerao “A Low Cost Smart Irrigation System using MOTT Protocol”, IEEE 2017
- [15] J.J. Rodriguez-Andina, M.J. Moure, M.D. ValdesFeatures, design tools, and application domains of FPGAs IEEE Trans. Ind. Electron., 54 (4) (Aug. 2007), pp. 1810-1823
- [16] <https://www.google.com>
- [17] S. Harishankar, R. Sathish Kumar, SudharsanK.P, U. Vignesh and TViveknath,2014, Solar Powered Smart Irrigation System, Advance in Electronic and Electric Engineering. ISSN 2231-1297, Volume 4, Number 4, pp. 341-346, Research India Publications.
- [18] Md Saifudaullah Bin Baharudin and Rosnin Abu Kassim, “Development of

Fire Alarm System using Raspberry Pi and Arduino Uno” 2013 International Conference on Electrical, Electronics and System Engineering.

[19] Jainishkuamr Anghan<sup>1</sup>, Parveen Sultana H<sup>1</sup>, Smart Irrigation System using Raspberry Pi, International Journal of Scientific & Engineering Research, Volume 9, Issue 6, June-2018, ISSN 2229-5518.

[20] Pothabathina Shirisha, Jammula Madhuri, Irrigation System Using Raspberry PI and GSM, IJMETR Journal, ISSN 2348-4845, pp.54-61.

[21] J.J. Rodríguez-Andina, M.D. Valdés-Peña, M.J. Moure, Advanced features and industrial applications of FPGAs—a review, IEEE Trans. Ind. Inf., 11 (4) (Aug. 2015), pp. 853-864.

[22] K. Prathyusha and Chaitanya Suman, 2012, Design of embedded systems for the automation of drip irrigation, International Journal of Application or Innovation in Engineering & Management (IJAIEEM), Volume 1, Issue 2. pp. 254-258.

[23] Satyendra Tripathi, Lakshmi N., Sai Apoorva and U. A. Vasan, Solar powered intelligent drip irrigation system for sustainable irrigation services, pp-1-8.

[24] A.R. Al Ali et al, IoT-solar energy powered smart farm irrigation system, Journal of Electronic Science and Technology, Volume 17, Issue 4, December 2019

[25] Ryu M, Yun J, Miao T, Ahn IY, Choi SC, Kim J (2015) “Design and implementation of a connected farm for smart farming system” 2015 IEEE, pp 1-4 (2015).