Design of High-Order CMOS Analog Notch Filter with 0.18 μm CMOS Technology

Kittipong Tripetch

Additional information is available at the end of the chapter

<http://dx.doi.org/10.5772/intechopen.73157>

Abstract

Analog notch filters schematics are very rare. Two circuit diagrams are reviewed with symbolic equations. The first schematic is analog notch filter based on twin-T circuit diagram. The second schematic is analog notch filter based on the Friend biquad circuit.

Keywords: analog notch filter, high-order filter, LCR prototype, interference rejection

1. Introduction

Notch filters or band stop filters have many types of applications. The first application is interference mitigation in GNSS receiver [1]. The second application is the removal of powerline noise from biomedical signals which have operating frequency range from 50 to 60 Hz, while biomedical signal such as EEG has magnitude response in the range of 1–40 Hz [2]. The third application is for a radio frequency image rejection [3]. The fourth application is for an interference rejection in UWB systems. In this application, the filter can notch the magnitude more than 35 db at operating frequency of 900 MHz [4].

A second-order notch can be constructed using an LCR passive prototype. The advent of the very large-scale integration allows tens of thousands of transistors to be fabricated in an integrated circuit. CMOS analog notch filters can be easily designed and built in an IC chip. There are many types of techniques to design analog filter at the architecture or block diagram level such as active RC filter, Gm-C filter, switched Capacitor filter, etc. In this chapter, we will design analog notch filter based on Gm-C filter block diagram.

2. Transconductor capacitor filter based on floating active inductors

There are many choices of transconductor in the literatures. The first transconductor was published by Nedungadi [5]. It is proposed since 1984. This transconductor is very linear; its linear range can be extended by design and simulation. The circuit diagram is shown in **Figure 1**. Its typical linear range, which is output current versus input voltage, can be plotted by level 1 transistor model as follows.

Drain current of an NMOS and a PMOS transistor can be expressed as follows [6]:

$$I_D = \frac{\mu_n C_{ox}}{2} \left(\frac{W}{L}\right) (V_{GS} - V_{TH})^2 (1 + \lambda V_{DS}) \tag{1}$$

$$-I_D = \frac{\mu_p C_{ox}}{2} \left(\frac{W}{L}\right) (V_{GS} - V_{TH})^2 (1 - \lambda V_{DS}) \tag{2}$$

where I_D is the drain current, μ_n is the electron mobility, μ_p is the hole mobility, C_{ox} is oxide thickness and λ is the channel length modulation.

For submicron CMOS, drain current of NMOS and PMOS transistor can be shown in the formulas (3) and (4). As a consequence of high electric field, both x and y dimensions are a derivative of electric field by distance along x- and y-axes:

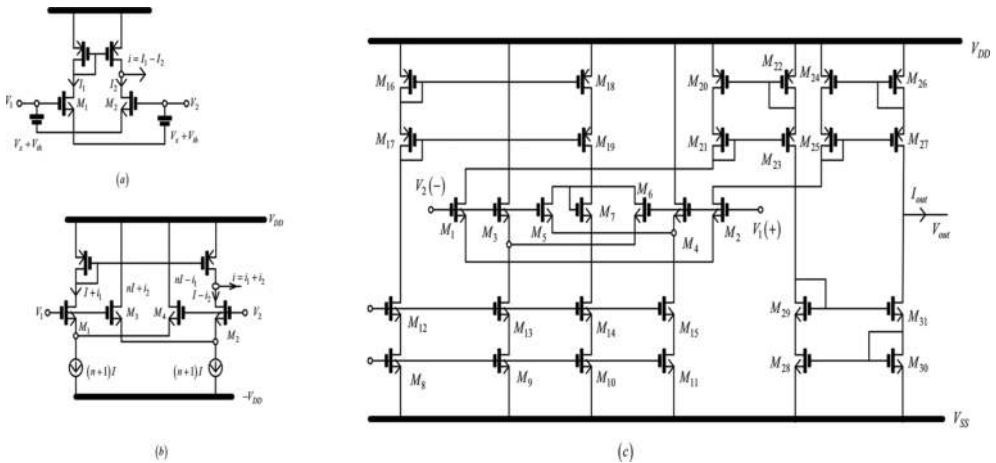

Figure 1. (a) Differential amplifier with cross couple concept, (b) replacement of ideal voltage source with transistor in (a), and (c) cross couple circuit diagram with cascade active load.

$$I_D = \frac{W}{L} \left(\frac{\mu_e C_{ox}}{1 + \frac{V_{DS}}{E_C L}} \right) \left(V_{GS} - V_{TH} - \frac{V_{DS}}{2} \right) V_{DS} \quad (3)$$

$$\mu_e = \frac{\mu_0}{1 + \left(\frac{V_{GS} - V_{TH}}{\theta_{tox}} \right) \eta'} \eta = 1.85 \text{ for } 0.13 \mu\text{m}$$

$$I_{DS} = W v_{sat} C_{ox} \frac{(V_{GS} - V_{TH})^2}{(V_{GS} - V_{TH}) + E_C L} \approx W v_{sat} C_{ox} (V_{GS} - V_{TH}) \quad (4)$$

$$E_C L \gg V_{GS} - V_{TH} \quad \text{for long channel device}$$

$$E_C L \ll V_{GS} - V_{TH} \quad \text{for short channel device}$$

In order for someone to plot linear range by using multiple transistors, output current can be written as a function input voltage by writing KVL around the loop. Another way of representation is to derive small signal transconductance gain in frequency domain which is a ratio of output current which flows out from the output node divided by input voltage. Small-signal equivalent circuit concept can make the circuit analysis difficult because of parasitic capacitance. Transconductor circuit diagram which has too many transistors may not work if it is believed in small-signal circuit concept because the circuit has too many poles and zeros which make the element substitution of transconductor to deviate from ideal transfer function of LCR prototype.

3. Second-order notch filter

Circuit idea of notch filter is very rare. This is because the theory of an ideal second-order transfer function is well defined. The notch filter or band reject filter is found to be expressed as (5) below [7]:

$$H(s) = \frac{s^2 + \omega_z^2}{s^2 + \left(\frac{\omega_p}{Q_p} \right) s + \omega_p^2} \quad (5)$$

where ω_z is the notch frequency, ω_p is a pole frequency and $\omega_z = \omega_p$.

Numerator polynomial can be designed to have any value so that the roots of the numerator polynomial have roots of it equal with complex zero after equating them with zero.

The circuit which implements this function is called twin-T RC network which can be drawn in **Figures 2 and 3**.

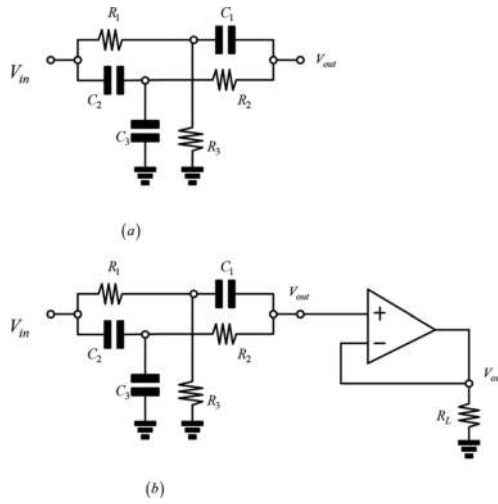

Figure 2. (a) Twin T network and (b) twin T network with buffered op-amp.

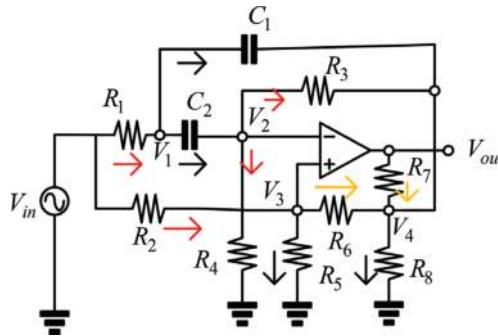

Figure 3. The Friend Biquad circuit.

A. Appendix

The notch filter block diagram is analyzed with Kirchoff current law to prove that it is notch filter transfer function. There are two notch circuits in this appendix. The passive element has its own name without any duplication of names. The current is assumed to flow from left to right and flow from positive potential to ground. Also assume that all nodes in the circuit have positive potential except ground node.

$$\left(\frac{V_{in} - V_1}{R_1}\right) = \frac{V_1}{R_3} + \frac{V_1 - V_{out}}{sC_1} \tag{6}$$

$$\frac{V_{in} - V_2}{sC_2} = \frac{V_2}{sC_3} + \frac{V_2 - V_{out}}{R_2} \tag{7}$$

$$\frac{V_1 - V_{out}}{sC_1} + \frac{V_2 - V_{out}}{R_2} = V_{out} \left(\frac{1}{R_4} + sC_4 \right) \quad (8)$$

$$\left(\frac{V_{in} - V_1}{R_1} \right) = \frac{V_1}{R_3} + \frac{V_1 - V_{out}}{sC_1} \quad (9)$$

$$(V_{in} - V_1)(sC_1R_3) = V_1(sC_1R_1) + (V_1 - V_{out})R_1R_3$$

$$V_{in}(sC_1R_3) = V_1(sC_1R_1 + sC_1R_3 + R_1R_3) - V_{out}(R_1R_3)$$

$$\frac{V_{in} - V_2}{sC_2} = \frac{V_2}{sC_3} + \frac{V_2 - V_{out}}{R_2} \quad (10)$$

$$(V_{in} - V_2)sC_3R_2 = V_2(sC_2R_2) + (V_2 - V_{out})s^2(C_2C_3)$$

$$V_{in}(sC_3R_2) = V_2(sC_3R_2 + sC_2R_2 + s^2C_2C_3) - V_{out}(s^2(C_2C_3))$$

$$V_2 = \frac{V_{in}(sC_3R_2) + V_{out}(s^2(C_2C_3))}{(sC_3R_2 + sC_2R_2 + s^2C_2C_3)}$$

$$\frac{V_1 - V_{out}}{sC_1} + \frac{V_2 - V_{out}}{R_2} = V_{out} \left(\frac{1}{R_4} + sC_4 \right) = V_{out} \frac{(1 + sC_4R_4)}{R_4} \quad (11)$$

$$(V_1 - V_{out})R_2R_4 + (V_2 - V_{out})sC_1R_4 = V_{out}(1 + sC_4R_4)(sC_1R_2)$$

$$V_1(R_2R_4) + V_2(sC_1R_4) = V_{out}(sC_1R_2 + s^2C_4R_4C_1R_2 + R_2R_4 + sC_1R_4)$$

$$V_1 = \left[\frac{V_{out}(s^2C_4R_4C_1R_2 + s(C_1R_2 + C_1R_4) + R_2R_4) - V_2(sC_1R_4)}{(R_2R_4)} \right]$$

$$= \left[\frac{V_{out}(s^2a_{21} + sa_{11} + a_{01}) - V_2(sC_1R_4)}{(R_2R_4)} \right]$$

Substitute Eq. (11) into an Eq. (9):

$$\left(\frac{V_{in} - V_1}{R_1} \right) = \frac{V_1}{R_3} + \frac{V_1 - V_{out}}{sC_1}$$

$$(V_{in} - V_1)(sC_1R_3) = V_1(sC_1R_1) + (V_1 - V_{out})R_1R_3$$

$$V_{in}(sC_1R_3) = V_1(sC_1R_1 + sC_1R_3 + R_1R_3) - V_{out}(R_1R_3)$$

$$V_{in}(sC_1R_3) = \left[\frac{V_{out}(s^2a_{21} + sa_{11} + a_{01}) - V_2(sC_1R_4)}{(R_2R_4)} \right] (sC_1R_1 + sC_1R_3 + R_1R_3) - V_{out}(R_1R_3)$$

$$V_{in}(sC_1R_3(R_2R_4)) = [V_{out}(s^2a_{21} + sa_{11} + a_{01}) - V_2(sC_1R_4)](sC_1R_1 + sC_1R_3 + R_1R_3) - V_{out}(R_1R_3)(R_2R_4)$$

$$V_{in}(sa_{12}) = V_{out}[(s^2a_{21} + sa_{11} + a_{01})(s(C_1R_1 + sC_1R_3) + R_1R_3) - (R_1R_3)(R_2R_4)] - V_2(sC_1R_4)(s(C_1R_1 + C_1R_3) + R_1R_3) \quad (12)$$

Substitute an Eq. (10) into an Eq. (12):

$$\begin{aligned}
V_{in}(sa_{12}) &= V_{out} [(s^2 a_{21} + sa_{11} + a_{01})(s(C_1 R_1 + sC_1 R_3) + R_1 R_3) - (R_1 R_3)(R_2 R_4)] \\
&\quad - V_2(sC_1 R_4)(s(C_1 R_1 + C_1 R_3) + R_1 R_3) \\
V_{in}(sa_{12}) &= V_{out} [(s^2 a_{21} + sa_{11} + a_{01})(s(C_1 R_1 + sC_1 R_3) + R_1 R_3) - (R_1 R_3)(R_2 R_4)] \\
&\quad - \left[\frac{V_{in}(sC_3 R_2) + V_{out}(s^2(C_2 C_3))}{(sC_3 R_2 + sC_2 R_2 + s^2 C_2 C_3)} \right] (sC_1 R_4)(s(C_1 R_1 + C_1 R_3) + R_1 R_3) \\
V_{in}(sa_{12}) \left(\begin{array}{c} s(C_3 R_2 + C_2 R_2) \\ +s^2 C_2 C_3 \end{array} \right) &= V_{out} [(s^2 a_{21} + sa_{11} + a_{01})(s(C_1 R_1 + sC_1 R_3) + R_1 R_3) - (R_1 R_3)(R_2 R_4)] \\
&\quad (sC_3 R_2 + sC_2 R_2 + s^2 C_2 C_3) - [V_{in}(sC_3 R_2) + V_{out}(s^2(C_2 C_3))] (sC_1 R_4)(s(C_1 R_1 + C_1 R_3) + R_1 R_3)
\end{aligned} \tag{13}$$

$$\begin{aligned}
V_{in}(sa_{12}) \left(\begin{array}{c} s(C_3 R_2 + C_2 R_2) \\ +s^2 C_2 C_3 \end{array} \right) &= V_{out} [(s^2 a_{21} + sa_{11} + a_{01})(s(C_1 R_1 + C_1 R_3) + R_1 R_3) - (R_1 R_3)(R_2 R_4)] \\
&\quad (s(C_3 R_2 + C_2 R_2) + s^2 C_2 C_3) - [V_{in}(sC_3 R_2) + V_{out}(s^2(C_2 C_3))] (sC_1 R_4)(s(C_1 R_1 + C_1 R_3) + R_1 R_3) \\
&\quad V_{in} [s^3(a_{12} C_2 C_3) + s^2 a_{12}(C_3 R_2 + C_2 R_2)] \\
&= V_{out} \left[\begin{array}{c} s^3 a_{21}(C_1 R_1 + sC_1 R_3) + s^2 \left(\begin{array}{c} a_{21}(R_1 R_3 - (R_1 R_3)(R_2 R_4)) \\ +a_{11}(C_1 R_1 + C_1 R_3) \end{array} \right) \\ +s[(a_{11})(R_1 R_3 - (R_1 R_3)(R_2 R_4)) + a_{01}(C_1 R_1 + C_1 R_3)] \\ +a_{01}(R_1 R_3 - (R_1 R_3)(R_2 R_4)) \end{array} \right] (s(C_3 R_2 + C_2 R_2) + s^2 C_2 C_3) \tag{14} \\
&\quad - V_{in} [s^3(C_3 R_2 C_1 R_4)(C_1 R_1 + C_1 R_3) + sC_3 R_2 R_1 R_3] - V_{out} [s^3 C_2 C_3 C_1 R_4(C_1 R_1 + C_1 R_3) + s^2 C_2 C_3 R_1 R_3] \\
V_{in} [s^3(a_{12} C_2 C_3) + s^2 a_{12}(C_3 R_2 + C_2 R_2)] &= V_{out} [s^3 a_{33} + s^2 a_{23} + sa_{13} + a_{03}] (s(C_3 R_2 + C_2 R_2) + s^2 C_2 C_3) \\
- V_{in} [s^3(C_3 R_2 C_1 R_4)(C_1 R_1 + C_1 R_3) + sC_3 R_2 R_1 R_3] &- V_{out} [s^3 C_2 C_3 C_1 R_4(C_1 R_1 + C_1 R_3) + s^2 C_2 C_3 R_1 R_3] \\
a_{33} = a_{21}(C_1 R_1 + sC_1 R_3), a_{23} &= \left(\begin{array}{c} a_{21}(R_1 R_3 - (R_1 R_3)(R_2 R_4)) \\ +a_{11}(C_1 R_1 + C_1 R_3) \end{array} \right), \\
a_{13} &= [(a_{11})(R_1 R_3 - (R_1 R_3)(R_2 R_4)) + a_{01}(C_1 R_1 + C_1 R_3)] \\
a_{03} &= a_{01}(R_1 R_3 - (R_1 R_3)(R_2 R_4)) \\
V_{in} [s^3(a_{12} C_2 C_3 + (C_3 R_2 C_1 R_4)(C_1 R_1 + C_1 R_3)) + s^2 a_{12}(C_3 R_2 + C_2 R_2) + sC_3 R_2 R_1 R_3] \\
&= V_{out} [s^3 a_{33} + s^2 a_{23} + sa_{13} + a_{03}] (s(C_3 R_2 + C_2 R_2) + s^2 C_2 C_3) \\
&\quad - V_{out} [s^3 C_2 C_3 C_1 R_4(C_1 R_1 + C_1 R_3) + s^2 C_2 C_3 R_1 R_3] \\
a_{34} = (a_{12} C_2 C_3 + (C_3 R_2 C_1 R_4)(C_1 R_1 + C_1 R_3)), a_{24} &= a_{12}(C_3 R_2 + C_2 R_2), a_{14} = C_3 R_2 R_1 R_3
\end{aligned} \tag{15}$$

$$V_{in} [s^3 a_{34} + s^2 a_{24} + s a_{14}] = V_{out} [s^3 a_{33} + s^2 a_{23} + s a_{13} + a_{03}] (s(C_3 R_2 + C_2 R_2) + s^2 C_2 C_3) - V_{out} [s^3 a_{35} + s^2 a_{25}]$$

$$a_{34} = (a_{12} C_2 C_3 + (C_3 R_2 C_1 R_4)(C_1 R_1 + C_1 R_3)), a_{24} = a_{12}(C_3 R_2 + C_2 R_2), a_{14} = C_3 R_2 R_1 R_3$$

$$a_{35} = C_2 C_3 C_1 R_4 (C_1 R_1 + C_1 R_3), a_{25} = C_2 C_3 R_1 R_3$$

$$V_{in} [s^3 a_{34} + s^2 a_{24} + s a_{14}] = V_{out} \begin{bmatrix} s^5 a_{33} C_2 C_3 + s^4 (a_{23} C_2 C_3 + a_{33} (C_3 R_2 + C_2 R_2)) \\ + s^3 (a_{23} (C_3 R_2 + C_2 R_2) + a_{13} (C_3 R_2 + C_2 R_2) - a_{35}) \\ + s^2 (a_{13} (C_3 R_2 + C_2 R_2) + a_{03} C_2 C_3 - a_{25}) \\ s a_{03} (C_3 R_2 + C_2 R_2) \end{bmatrix}$$

$$\frac{V_{out}}{V_{in}} = \frac{[s^3 a_{34} + s^2 a_{24} + s a_{14}]}{\begin{bmatrix} s^5 a_{33} C_2 C_3 + s^4 (a_{23} C_2 C_3 + a_{33} (C_3 R_2 + C_2 R_2)) \\ + s^3 (a_{23} (C_3 R_2 + C_2 R_2) + a_{13} (C_3 R_2 + C_2 R_2) - a_{35}) \\ + s^2 (a_{13} (C_3 R_2 + C_2 R_2) + a_{03} C_2 C_3 - a_{25}) \\ s a_{03} (C_3 R_2 + C_2 R_2) \end{bmatrix}}$$

$$= \frac{s[s^2 a_{34} + s a_{24} + a_{14}]}{\begin{bmatrix} s^4 a_{33} C_2 C_3 + s^3 (a_{23} C_2 C_3 + a_{33} (C_3 R_2 + C_2 R_2)) \\ + s^2 (a_{23} (C_3 R_2 + C_2 R_2) + a_{13} (C_3 R_2 + C_2 R_2) - a_{35}) \\ + s (a_{13} (C_3 R_2 + C_2 R_2) + a_{03} C_2 C_3 - a_{25}) \\ + a_{03} (C_3 R_2 + C_2 R_2) \end{bmatrix}}$$

(16)

KCL at V_1 :

$$\left(\frac{V_{in} - V_1}{R_1} \right) = (V_1 - V_4) s C_1 + (V_1 - V_2) s C_2$$

$$V_{in} - V_1 = V_1 (s C_1 R_1 + s C_2 R_1) - V_2 (s C_2 R_1) - V_4 (s C_1 R_1)$$

$$V_{in} = V_1 (s C_1 R_1 + s C_2 R_1 + 1) - V_2 (s C_2 R_1) - V_4 (s C_1 R_1)$$

$$V_{in} - V_1 x_1 + V_2 x_2 + V_4 x_3 = 0$$

$$x_1 = (s C_1 R_1 + s C_2 R_1 + 1)$$

$$x_2 = (s C_2 R_1)$$

$$x_3 = (s C_1 R_1)$$

(17)

KCL at V_2 :

$$\begin{aligned}
(V_1 - V_2)sC_2 &= \left(\frac{V_2 - V_4}{R_3}\right) + \frac{V_2}{R_4} \\
V_1(sC_2) &= V_2\left(sC_2 + \frac{1}{R_3} + \frac{1}{R_4}\right) - V_4\left(\frac{1}{R_3}\right) \\
V_1(sC_2) - V_2x_4 + V_4x_5 &= 0 \\
x_4 &= \left(sC_2 + \frac{1}{R_3} + \frac{1}{R_4}\right) \\
x_5 &= \left(\frac{1}{R_3}\right)
\end{aligned} \tag{18}$$

KCL at V_3 :

$$\begin{aligned}
\left(\frac{V_{in} - V_3}{R_2}\right) &= \frac{V_3}{R_5} + \left(\frac{V_3 - V_4}{R_6}\right) \\
\frac{V_{in}}{R_2} &= V_3\left(\frac{1}{R_2} + \frac{1}{R_5} + \frac{1}{R_6}\right) - V_4\left(\frac{1}{R_6}\right) \\
V_{in}x_6 - V_3x_7 + V_4x_8 &= 0 \\
x_6 &= \frac{1}{R_2} \\
x_7 &= \left(\frac{1}{R_2} + \frac{1}{R_5} + \frac{1}{R_6}\right) \\
x_8 &= \left(\frac{1}{R_6}\right)
\end{aligned} \tag{19}$$

KCL at V_4 :

$$\begin{aligned}
\frac{V_3 - V_4}{R_6} + \left(\frac{V_{out} - V_4}{R_7}\right) &= \frac{V_4}{R_8} \\
\frac{V_3}{R_6} - V_4\left(\frac{1}{R_6} + \frac{1}{R_7} + \frac{1}{R_8}\right) + \frac{V_{out}}{R_7} &= 0 \\
V_3x_9 - V_4x_{10} + V_{out}x_{11} &= 0 \\
x_9 &= \frac{1}{R_6} \\
x_{10} &= \left(\frac{1}{R_6} + \frac{1}{R_7} + \frac{1}{R_8}\right) \\
x_{11} &= \frac{1}{R_7}
\end{aligned} \tag{20}$$

KCL at V_{out} :

$$\begin{aligned}
 A_v(V_3 - V_2) &= \frac{V_{out} - V_4}{R_7} \\
 -V_2A_v + V_3A_v + \frac{V_4}{R_7} - \frac{V_{out}}{R_7} &= 0 \\
 -V_2A_v + V_3A_v + x_{12}V_4 - x_{12}V_{out} &= 0 \\
 x_{12} &= \frac{1}{R_7}
 \end{aligned} \tag{21}$$

All of these equations can be written in matrix form as follows:

$$\begin{bmatrix} 1 & -x_1 & x_2 & 0 & x_3 & 0 \\ 0 & sC_2 & -x_4 & 0 & x_5 & 0 \\ x_6 & 0 & 0 & -x_7 & x_8 & 0 \\ 0 & 0 & 0 & x_9 & -x_{10} & x_{11} \\ 0 & 0 & -A_v & A_v & x_{12} & x_{12} \end{bmatrix} \begin{bmatrix} V_{in} \\ V_1 \\ V_2 \\ V_3 \\ V_4 \\ V_{out} \end{bmatrix} = \begin{bmatrix} 0 \\ 0 \\ 0 \\ 0 \\ 0 \\ 0 \end{bmatrix} \tag{22}$$

From Eq. (17), it can be rewritten as follows:

$$\begin{aligned}
 V_{in} - V_1x_1 + V_2x_2 + V_4x_3 &= 0 \\
 V_{in} &= V_1x_1 - V_2x_2 - V_4x_3
 \end{aligned} \tag{23}$$

Substitute Eq. (23) into Eq. (19); we will get the following equation:

$$\begin{aligned}
 V_{in} &= V_1x_1 - V_2x_2 - V_4x_3 \\
 V_{in}x_6 - V_3x_7 + V_4x_8 &= 0 \\
 (V_1x_1 - V_2x_2 - V_4x_3)x_6 - V_3x_7 + V_4x_8 &= 0 \\
 V_1(x_1x_6) - V_2(x_2x_6) - V_3x_7 + V_4(x_8 - x_3x_6) &= 0 \\
 V_1(y_1) - V_2(y_2) - V_3x_7 + V_4(y_3) &= 0 \\
 y_1 = (x_1x_6) &= \frac{[s(C_1R_1 + C_2R_1) + 1]}{R_2} \\
 y_2 = (x_2x_6) &= \frac{(sC_2R_1)}{R_2} \\
 y_3 = (x_8 - x_3x_6) &= \frac{1}{R_6} - \frac{(sC_1R_1)}{R_2} = \frac{R_2 - (sC_1R_1R_6)}{R_6R_2}
 \end{aligned} \tag{24}$$

All of these equations can be written in matrix form as follows:

$$\begin{bmatrix} 1 & -x_1 & x_2 & 0 & x_3 & 0 \\ 0 & sC_2 & -x_4 & 0 & x_5 & 0 \\ 0 & y_1 & -y_2 & -x_7 & y_3 & 0 \\ 0 & 0 & 0 & x_9 & -x_{10} & x_{11} \\ 0 & 0 & -A_v & A_v & x_{12} & x_{12} \\ 0 & 0 & 0 & 0 & 0 & 0 \end{bmatrix} \begin{bmatrix} V_{in} \\ V_1 \\ V_2 \\ V_3 \\ V_4 \\ V_{out} \end{bmatrix} = \begin{bmatrix} 0 \\ 0 \\ 0 \\ 0 \\ 0 \\ 0 \end{bmatrix} \quad (25)$$

From Eq. (24), it can be rewritten as follows:

$$\begin{aligned} V_1(y_1) - V_2(y_2) - V_3x_7 + V_4(y_3) &= 0 \\ V_1 &= \left(\frac{V_2y_2 + V_3x_7 - V_4y_3}{y_1} \right) \end{aligned} \quad (26)$$

Substitute Eq. (26) into Eq. (17); we will get the following equation:

$$\begin{aligned} V_1 &= \left(\frac{V_2y_2 + V_3x_7 - V_4y_3}{y_1} \right) \\ V_{in} - V_1x_1 + V_2x_2 + V_4x_3 &= 0 \\ V_{in} - \left(\frac{V_2y_2 + V_3x_7 - V_4y_3}{y_1} \right)x_1 + V_2x_2 + V_4x_3 &= 0 \\ V_{in} + V_2 \left(x_2 - \frac{y_2x_1}{y_1} \right) - V_3 \left(\frac{x_7x_1}{y_1} \right) + V_4 \left(x_3 - \frac{y_3x_1}{y_1} \right) &= 0 \\ V_{in} + V_2y_4 - V_3y_5 + V_4y_6 &= 0 \\ y_4 &= \left(x_2 - \frac{y_2x_1}{y_1} \right) = sC_2R_1 - \left(\frac{sC_2R_1}{R_2} \right) \left(\frac{s(C_1R_1 + C_2R_1) + 1}{s(C_1R_1 + C_2R_1) + 1} \right) (R_2) = 0 \\ y_5 &= \left(\frac{x_7x_1}{y_1} \right) = \left(\frac{1}{R_2} + \frac{1}{R_5} + \frac{1}{R_6} \right) \left[\frac{s(C_1R_1 + C_2R_1) + 1}{s(C_1R_1 + C_2R_1) + 1} \right] R_2 = \left(\frac{R_2}{R_2} + \frac{R_2}{R_5} + \frac{R_2}{R_6} \right) \\ y_6 &= \left(x_3 - \frac{y_3x_1}{y_1} \right) = sC_1R_1 - \left[\frac{R_2 - sC_1R_1R_6}{R_6R_2} \right] \left[\frac{(s(C_1R_1 + C_2R_1) + 1)R_2}{(s(C_1R_1 + C_2R_1) + 1)} \right] \\ &= sC_1R_1 - \left[\frac{R_2 - sC_1R_1R_6}{R_6} \right] = s(2C_1R_1) - \left(\frac{R_2}{R_6} \right) \end{aligned} \quad (27)$$

All of these equations can be written in matrix form as follows:

$$\begin{bmatrix} 1 & 0 & y_4 & -y_5 & y_6 & 0 \\ 0 & sC_2 & -x_4 & 0 & x_5 & 0 \\ 0 & y_1 & -y_2 & -x_7 & y_3 & 0 \\ 0 & 0 & 0 & x_9 & -x_{10} & x_{11} \\ 0 & 0 & -A_v & A_v & x_{12} & x_{12} \\ 0 & 0 & 0 & 0 & 0 & 0 \end{bmatrix} \begin{bmatrix} V_{in} \\ V_1 \\ V_2 \\ V_3 \\ V_4 \\ V_{out} \end{bmatrix} = \begin{bmatrix} 0 \\ 0 \\ 0 \\ 0 \\ 0 \\ 0 \end{bmatrix} \quad (28)$$

From Eq. (18), it can be rewritten as follows:

$$\begin{aligned} V_1(sC_2) - V_2x_4 + V_4x_5 &= 0 \\ V_1 &= \left(\frac{V_2x_4 - V_4x_5}{sC_2} \right) \end{aligned} \quad (29)$$

Substitute Eq. (29) into Eq. (24); we will get the following equation:

$$\begin{aligned} V_1 &= \left(\frac{V_2x_4 - V_4x_5}{sC_2} \right) \\ V_1(y_1) - V_2(y_2) - V_3x_7 + V_4(y_3) &= 0 \\ \left(\frac{V_2x_4 - V_4x_5}{sC_2} \right)(y_1) - V_2(y_2) - V_3x_7 + V_4(y_3) &= 0 \\ V_2 \left(\frac{x_4y_1}{sC_2} - y_2 \right) - V_3x_7 + V_4 \left(y_3 - \frac{x_5y_1}{sC_2} \right) &= 0 \\ V_2y_7 - V_3x_7 + V_4y_8 &= 0 \\ y_7 &= \left(\frac{x_4y_1}{sC_2} - y_2 \right) = \left(sC_2 + \frac{1}{R_3} + \frac{1}{R_4} \right) \left(\frac{s(C_1R_1 + C_2R_1) + 1}{sC_2R_2} \right) - \left(\frac{sC_2R_1}{R_2} \right) \\ y_7 &= \frac{\left(sC_2 + \frac{1}{R_3} + \frac{1}{R_4} \right) (s(C_1R_1 + C_2R_1) + 1) - (sC_2R_1)sC_2}{sC_2R_2} \\ &= \frac{s^2C_2(C_1R_1) + s \left[C_2 + \left(\frac{1}{R_3} + \frac{1}{R_4} \right) (C_1R_1 + C_2R_1) \right] + \left(\frac{1}{R_3} + \frac{1}{R_4} \right)}{sC_2R_2} \\ y_8 &= \left(y_3 - \frac{x_5y_1}{sC_2} \right) = \frac{R_2 - (sC_1R_1R_6)}{R_6R_2} - \frac{1}{sC_2R_3} \left(\frac{[s(C_1R_1 + C_2R_1) + 1]}{R_2} \right) \\ &= \frac{(R_2 - (sC_1R_1R_6))sC_2R_3 - R_6([s(C_1R_1 + C_2R_1) + 1])}{sC_2R_2R_3R_6} \\ y_8 &= \frac{-s^2(C_1R_1R_6C_2R_3) + s(R_2C_2R_3 - R_6C_1R_1 - R_6C_2R_1) - R_6}{sC_2R_2R_3R_6} \end{aligned} \quad (30)$$

All of these equations can be written in matrix form as follows:

$$\begin{bmatrix} 1 & 0 & y_4 & -y_5 & y_6 & 0 \\ 0 & sC_2 & -x_4 & 0 & x_5 & 0 \\ 0 & 0 & y_7 & -x_7 & y_8 & 0 \\ 0 & 0 & 0 & x_9 & -x_{10} & x_{11} \\ 0 & 0 & -A_v & A_v & x_{12} & x_{12} \\ 0 & 0 & 0 & 0 & 0 & 0 \end{bmatrix} \begin{bmatrix} V_{in} \\ V_1 \\ V_2 \\ V_3 \\ V_4 \\ V_{out} \end{bmatrix} = \begin{bmatrix} 0 \\ 0 \\ 0 \\ 0 \\ 0 \\ 0 \end{bmatrix} \quad (31)$$

From Eq. (30), it can be rewritten as follows:

$$\begin{aligned} V_2 y_7 - V_3 x_7 + V_4 y_8 &= 0 \\ V_2 &= \left(\frac{V_3 x_7 - V_4 y_8}{y_7} \right) \end{aligned} \quad (32)$$

It is time to eliminate column 3 by Eq. (32) by substituting into Eq. (27):

$$\begin{aligned} V_2 &= \left(\frac{V_3 x_7 - V_4 y_8}{y_7} \right) \\ V_{in} + V_2 y_4 - V_3 y_5 + V_4 y_6 &= 0 \\ V_{in} + \left(\frac{V_3 x_7 - V_4 y_8}{y_7} \right) y_4 - V_3 y_5 + V_4 y_6 &= 0 \\ V_{in} + V_3 \left(\frac{x_7 y_4}{y_7} - y_5 \right) + V_4 \left(y_6 - \frac{y_8 y_4}{y_7} \right) &= 0 \\ V_{in} + V_3 y_9 + V_4 y_{10} &= 0 \\ y_9 &= \left(\frac{x_7 y_4}{y_7} - y_5 \right) \\ y_{10} &= \left(y_6 - \frac{y_8 y_4}{y_7} \right) \end{aligned} \quad (33)$$

Update matrix in Eq. (31) by substituting Eq. (33) into as follows:

$$\begin{bmatrix} 1 & 0 & \mathbf{0} & y_9 & y_{10} & 0 \\ 0 & sC_2 & -x_4 & 0 & x_5 & 0 \\ 0 & \mathbf{0} & y_7 & -x_7 & y_8 & 0 \\ 0 & 0 & 0 & x_9 & -x_{10} & x_{11} \\ 0 & 0 & -A_v & A_v & x_{12} & x_{12} \\ 0 & 0 & 0 & 0 & 0 & 0 \end{bmatrix} \begin{bmatrix} V_{in} \\ V_1 \\ V_2 \\ V_3 \\ V_4 \\ V_{out} \end{bmatrix} = \begin{bmatrix} 0 \\ 0 \\ 0 \\ 0 \\ 0 \\ 0 \end{bmatrix} \quad (34)$$

It is time to eliminate column 3 by Eq. (32) by substituting into Eq. (29):

$$\begin{aligned} V_2 &= \left(\frac{V_3 x_7 - V_4 y_8}{y_7} \right) \\ V_1 (sC_2) - V_2 x_4 + V_4 x_5 &= 0 \\ V_1 (sC_2) - \left(\frac{V_3 x_7 - V_4 y_8}{y_7} \right) x_4 + V_4 x_5 &= 0 \\ V_1 (sC_2) - V_3 \left(\frac{x_7 x_4}{y_7} \right) + V_4 \left(x_5 + \frac{y_8 x_4}{y_7} \right) &= 0 \\ V_1 (sC_2) - V_3 y_{11} + V_4 y_{12} &= 0 \end{aligned} \quad (35)$$

Update matrix in Eq. (34) by substituting Eq. (35) into as follows:

$$\begin{matrix} (1.4) \\ (2.3) \\ (3.3) \end{matrix} \begin{bmatrix} 1 & 0 & 0 & y_9 & y_{10} & 0 \\ 0 & sC_2 & 0 & -y_{11} & y_{12} & 0 \\ 0 & 0 & y_7 & -x_7 & y_8 & 0 \\ 0 & 0 & 0 & x_9 & -x_{10} & x_{11} \\ 0 & 0 & -A_v & A_v & x_{12} & x_{12} \end{bmatrix} \begin{bmatrix} V_{in} \\ V_1 \\ V_2 \\ V_3 \\ V_4 \\ V_{out} \end{bmatrix} = \begin{bmatrix} 0 \\ 0 \\ 0 \\ 0 \\ 0 \\ 0 \end{bmatrix} \quad (36)$$

It is time to eliminate column 3 by Eq. (32) by substituting into Eq. (21):

$$\begin{aligned} V_2 &= \left(\frac{V_3 x_7 - V_4 y_8}{y_7} \right) \\ -V_2 A_v + V_3 A_v + x_{12} V_4 - x_{12} V_{out} &= 0 \\ -\left(\frac{V_3 x_7 - V_4 y_8}{y_7} \right) A_v + V_3 A_v + x_{12} V_4 - x_{12} V_{out} &= 0 \\ V_3 \left(A_v - \frac{x_7 A_v}{y_7} \right) + V_4 \left(x_{12} + \frac{y_8 A_v}{y_7} \right) - V_{out} x_{12} &= 0 \\ V_3 z_1 + V_4 z_2 - V_{out} x_{12} &= 0 \end{aligned} \quad (37)$$

Update matrix in Eq. (34) by substituting Eq. (37) into as follows:

$$\begin{bmatrix} 1 & 0 & 0 & y_9 & y_{10} & 0 \\ 0 & sC_2 & 0 & -y_{11} & y_{12} & 0 \\ 0 & 0 & y_7 & -x_7 & y_8 & 0 \\ 0 & 0 & 0 & x_9 & -x_{10} & x_{11} \\ 0 & 0 & 0 & z_1 & z_2 & -x_{12} \\ 0 & 0 & 0 & 0 & 0 & 0 \end{bmatrix} \begin{bmatrix} V_{in} \\ V_1 \\ V_2 \\ V_3 \\ V_4 \\ V_{out} \end{bmatrix} = \begin{bmatrix} 0 \\ 0 \\ 0 \\ 0 \\ 0 \\ 0 \end{bmatrix} \quad (38)$$

From Eq. (20), it can be rewritten as follows:

$$\begin{aligned} V_3 x_9 - V_4 x_{10} + V_{out} x_{11} &= 0 \\ V_3 &= \left(\frac{V_4 x_{10} - V_{out} x_{11}}{x_9} \right) \end{aligned} \quad (39)$$

Substitute Eq. (39) into Eq. (37); we will get the following equation:

$$\begin{aligned}
 V_3 &= \left(\frac{V_4 x_{10} - V_{out} x_{11}}{x_9} \right) \\
 V_3 z_1 + V_4 z_2 - V_{out} x_{12} &= 0 \\
 \left(\frac{V_4 x_{10} - V_{out} x_{11}}{x_9} \right) z_1 + V_4 z_2 - V_{out} x_{12} &= 0 \\
 V_4 \left(\frac{x_{10} z_1}{x_9} + z_2 \right) - V_{out} \left(\frac{x_{11} z_1}{x_9} + x_{12} \right) &= 0 \\
 V_4 z_3 - V_{out} z_4 &= 0
 \end{aligned} \tag{40}$$

Update matrix in Eq. (36) by substituting Eq. (40) into as follows:

$$\begin{bmatrix} 1 & 0 & \mathbf{0} & y_9 & y_{10} & 0 \\ 0 & sC_2 & \mathbf{0} & -y_{11} & y_{12} & 0 \\ 0 & \mathbf{0} & y_7 & -x_7 & y_8 & 0 \\ 0 & 0 & 0 & x_9 & -x_{10} & x_{11} \\ 0 & 0 & \mathbf{0} & \mathbf{0} & z_3 & -z_4 \\ 0 & 0 & 0 & 0 & 0 & 0 \end{bmatrix} \begin{bmatrix} V_{in} \\ V_1 \\ V_2 \\ V_3 \\ V_4 \\ V_{out} \end{bmatrix} = \begin{bmatrix} 0 \\ 0 \\ 0 \\ 0 \\ 0 \\ 0 \end{bmatrix} \tag{41}$$

Substitute Eq. (39) into Eq. (30); we will get the following equation:

$$\begin{aligned}
 V_3 &= \left(\frac{V_4 x_{10} - V_{out} x_{11}}{x_9} \right) \\
 V_2 y_7 - V_3 x_7 + V_4 y_8 &= 0 \\
 V_2 y_7 - \left(\frac{V_4 x_{10} - V_{out} x_{11}}{x_9} \right) x_7 + V_4 y_8 &= 0 \\
 V_2 y_7 + V_4 \left(y_8 - \frac{x_{10} x_7}{x_9} \right) + V_{out} \left(\frac{x_{11} x_7}{x_9} \right) &= 0 \\
 V_2 y_7 + V_4 z_5 + V_{out} z_6 &= 0
 \end{aligned} \tag{42}$$

Update matrix in Eq. (41) by substituting Eq. (40) into as follows:

$$\begin{bmatrix} 1 & 0 & \mathbf{0} & y_9 & y_{10} & 0 \\ 0 & sC_2 & \mathbf{0} & -y_{11} & y_{12} & 0 \\ 0 & \mathbf{0} & y_7 & \mathbf{0} & z_5 & z_6 \\ 0 & 0 & 0 & x_9 & -x_{10} & x_{11} \\ 0 & 0 & \mathbf{0} & \mathbf{0} & z_3 & -z_4 \\ 0 & 0 & 0 & 0 & 0 & 0 \end{bmatrix} \begin{bmatrix} V_{in} \\ V_1 \\ V_2 \\ V_3 \\ V_4 \\ V_{out} \end{bmatrix} = \begin{bmatrix} 0 \\ 0 \\ 0 \\ 0 \\ 0 \\ 0 \end{bmatrix} \tag{43}$$

Substitute Eq. (39) into Eq. (33); we will get the following equation:

$$\begin{aligned}
 V_3 &= \left(\frac{V_4 x_{10} - V_{out} x_{11}}{x_9} \right) \\
 V_{in} + V_3 y_9 + V_4 y_{10} &= 0 \\
 V_{in} + \left(\frac{V_4 x_{10} - V_{out} x_{11}}{x_9} \right) y_9 + V_4 y_{10} &= 0 \\
 V_{in} + V_4 \left(\frac{x_{10} y_9}{x_9} + y_{10} \right) - V_{out} \left(\frac{x_{11} y_9}{x_9} \right) &= 0 \\
 V_{in} + V_4 z_7 - V_{out} z_8 &= 0
 \end{aligned} \tag{44}$$

Update matrix in Eq. (43) by substituting Eq. (44) into as follows:

$$\begin{bmatrix} 1 & 0 & 0 & 0 & z_7 & -z_8 \\ 0 & sC_2 & 0 & -y_{11} & y_{12} & 0 \\ 0 & 0 & y_7 & 0 & z_5 & z_6 \\ 0 & 0 & 0 & x_9 & -x_{10} & x_{11} \\ 0 & 0 & 0 & 0 & z_3 & -z_4 \\ 0 & 0 & 0 & 0 & 0 & 0 \end{bmatrix} \begin{bmatrix} V_{in} \\ V_1 \\ V_2 \\ V_3 \\ V_4 \\ V_{out} \end{bmatrix} = \begin{bmatrix} 0 \\ 0 \\ 0 \\ 0 \\ 0 \\ 0 \end{bmatrix} \tag{45}$$

Substitute Eq. (37) into Eq. (44); we will get the following equation:

$$\begin{aligned}
 V_4 z_3 - V_{out} z_4 &= 0 \\
 V_4 &= V_{out} \left(\frac{z_4}{z_3} \right) \\
 V_{in} + V_4 z_7 - V_{out} z_8 &= 0 \\
 V_{in} + V_{out} \left(\frac{z_4}{z_3} \right) z_7 - V_{out} z_8 &= 0 \\
 V_{in} + V_{out} \left(\frac{z_4 z_7}{z_3} - z_8 \right) &= 0 \\
 V_{in} + V_{out} z_9 = 0 &\rightarrow \frac{V_{out}}{V_{in}} = -\frac{1}{z_9}
 \end{aligned} \tag{46}$$

Author details

Kittipong Tripetch

Address all correspondence to: kan1972@a2.keio.jp

Rajamangala University of Technology Suvarnabhumi, Japan

References

- [1] Borio D, Camoriano L, Presti LL. Two-pole and multi pole notch filters: A computationally effective solution for GNSS interference detection and mitigation. *IEEE Systems Journal*. 2008;**2**(1):38-47
- [2] Biswas U, Maniruzzaman Md. Removing power line interference from ECG signal using adaptive filter and notch filter. In: *ICEEICT*. 2014
- [3] Parthasarathy J, Harjani R. Novel Integratable Notch Filter Implementation for 100 dB Image Rejection. I-473-476
- [4] Valeese A, Bevilacqua A, Sandner C, Tiebout M, Gerosa A, Neviani A. Analysis and Design of an Integrated Notch Filter for the rejection of interference in UWB systems. *IEEE Journal of Solid-State Circuits*. February 2009;**44**(2):331-343
- [5] Adams WJ, Nedungadi A, Geiger RL. Design of a programmable OTA with multi decade transconductance adjustment. In: *ISCAS89*. pp. 663-666
- [6] Hodges DA, Jackson HG. *Analysis and Design of Digital Integrated Circuit*. 3rd ed. United States: Mcgraw-Hill; 2004
- [7] Daryanani G. *Principle of Active Network Synthesis and Design*. Singapore: Wiley; 1976