

## Chapter

# Impact of Working Fluids and Performance of Isobutane in the Refrigeration System

*Solomon O. Banjo, Bukola O. Bolaji, Oluseyi O. Ajayi and Olatunde A. Oyelaran*

## Abstract

The effect of heat transfer medium (HTM) on the environment is associated with ozone layer depletion and global warming. The role of HTM (working fluid) in the heating and air conditioning industries is paramount, which cannot be underestimated. The conventional refrigerant has been predominantly used over decades due to their thermodynamic properties. However, hydrocarbon refrigerants such as isobutane are considered substitutes because they have negligible global warming potential and zero ozone depletion. That makes it eco-friendly among other existing refrigerants. The investigation of the refrigeration system's performance characteristics required consideration for the coefficient of performance, refrigerating effect, and the compressor work; this enables the determination of the system's efficiency without any assumption. Another factor that suggests a better absorption of refrigerant (working fluid) into a refrigeration system is an increase in the coefficient of performance (COP). The effect will cause a reduction in the rate of energy consumption by the compressor. The result shows that the system's coefficient of performance when using R600a was 27.1% higher than when working with R134a, with an energy reduction of 23.3%.

**Keywords:** coefficient of performance, refrigerating effect, global warming potential, working fluid, ozone depletion potential

## 1. Introduction

At the beginning of the eighteenth century, natural ice was exploited for domestic and commercial purposes, such as food preservation. Also, in the 1800s, there was a discovery of volatile liquids that could condense by applying compression and cooling [1]. The combination of these two inventions results in the fabrication of the household refrigeration system, which has worldwide applications. Since the nineteenth centuries that vapor compression system (VCS) has been invented, its practical implementation has cut across various fields, including preservation of food and vaccine, heat ventilation and air-conditioning for human comfort, and storage of farm produce, and industrial processing. Preservation became essential to expand the product's shelf life, which enables the quality in terms of physical properties that include color, texture, and flavor. More so, the refrigeration process, among other food storage methods, has been proved to be

most effective, dependable, desirable, and applicable worldwide [2–5]. Over two decades ago, thermal systems have found increased application in the tropical region, and they consumed a massive amount of electrical energy. Furthermore, contrary to the excessive energy consumption rate exhibited by the refrigeration system (RS), the refrigerant plays a vital role in the overall performance of a vapor compression system [6].

The heat gained by the refrigerant in VCS flows in the direction of decreasing temperature, from the high-temperature region to the low-temperature region. Also, there are assumptions required for an ideal vapor compression system to occur. These include:

- the heat rejects to the immediate surroundings are ignored.
- there are no frictional pressure drops.
- working fluid flows at constant pressure in the condenser and evaporator, which serves as the refrigeration system’s heat exchangers.
- process of compression is isentropic the irreversibility process, within the essential components such as compressor, condenser, and evaporator, are ignored [7, 8].

More so, there are four processes involved in establishing low temperature in a refrigeration system was explained and represented by a pressure-enthalpy (p-h) diagram, as shown in **Figure 1**.

### 1.1 Isobaric heat absorption process

From **Figure 1**, point 4 to 1, the working fluid has low pressure and temperature in a vapourized form at constant pressure and temperature in the evaporator. The latent heat absorbed in the evaporator by the working fluid is expressed in Eq. (1). The phase change occurs as the refrigerant isentropically compressed by the compressor and moves to the next stage.

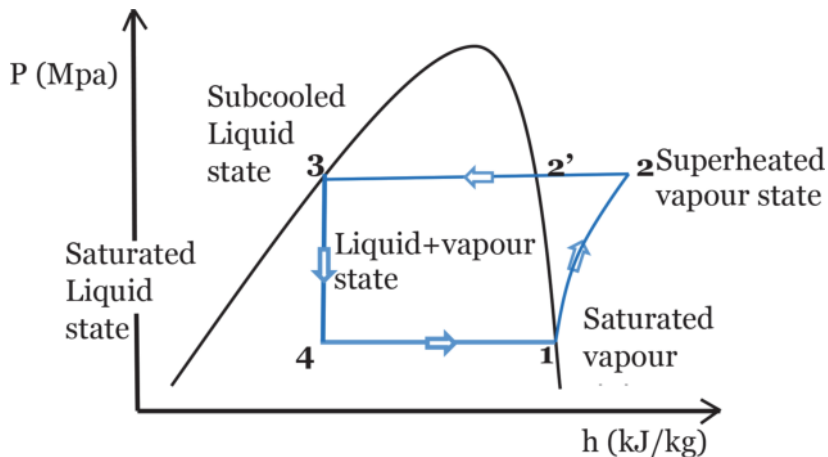

**Figure 1.**  
*P-h diagram of a vapor compression cycle.*

## 1.2 Isentropic compression process

The isentropic compression takes place in the compression line. The vaporized refrigerant from the evaporator is compressed isentropically from stages 1 to 2 by the compressor. Work done on working fluid by the compressor is given in Eq. (2). The compression force increased the refrigerant's pressure and temperature, resulting in the rise of pressure and temperature, as shown in **Figure 1**. And refrigerant attains its superheated state at point 2.

## 1.3 Isobaric heat rejection process

The superheated refrigerant was de-superheated at constant pressure through the compressor outlet temperature to the condenser temperature at point 2'. Then, condensation occurs due to the natural air that inter-phases with the condenser's extended surface, resulting in heat rejection from the refrigerant. Thus, reducing the temperature by condensation at the condenser enables the refrigerant to attain a sub-cool state at point 3 at constant pressure and constant temperature along the 2' and 3 as shown in **Figure 1**, and the heat loss is expressed in Eq. (5).

## 1.4 Isenthalpic expansion process

In this isenthalpic process, the pressure at the upstream consistently higher than the pressure at the low stream. The capillary tube (CT) is used in practice to replace the expansion or throttling valve in a vapor compression refrigeration system (VCRS). This component aims to drastically reduce the pressure of the refrigerant that throttles through stages 3 and 4. It is assumed that there is no heat gain or loss because the process is adiabatic, that is,  $h_3 = h_4$ , as displayed in **Figure 1**. Therefore, the refrigerant throttled down the capillary tube and moved to the evaporator inlet at point 4.

In cooling systems, emphasis is always on domestic refrigerators and air-conditioning (AC) systems. There are various types of refrigeration and AC systems. RS can be classified base on the kind of energy input and the refrigeration process as:

## 2. Natural refrigeration

### 2.1 Art of ice making by nocturnal cooling

The art of making ice by nocturnal cooling is a common method of producing ice in India. It involves keeping a thin layer of water in a deep earthen vessel such as a tray with compacted hay of about 0.3 m thickness, which serves as an insulator, and as the tray was exposed to cool air, water emits heat by radiation to the stratosphere, almost at  $-55^{\circ}\text{C}$ ; the water in the trays turns to ice [9].

### 2.2 Evaporative cooling

The evaporative cooling method has been adopted in India for many centuries to obtain cold water in summer by storing the water in earthen pots. The water penetrates through the pores of the earthen vessel to its outer surface where it evaporates to the immediate surrounding, and absorb its latent heat from the vessel, which cools the water. In recent days, desert coolers are used in hot and dry regions to provide cooling in summer [10, 11].

### 3. Non-natural refrigeration

#### 3.1 Vapor compression refrigeration systems

See Section 2.

#### 3.2 Thermoelectric refrigeration systems

The thermoelectric refrigeration system (TRS) uses electricity to provide cooling effect utilizing the principle of two dissimilar metals to generate emf. There are two basic methods in obtaining this operation, which include Peltier and Seebeck effect.

##### 3.2.1 Peltier effect

This requires the flow of electric current through two dissimilar conductors, and the junction of the metals (conductors) either emit or absorb heat, which depends on the current that flows across the junctions. However, the flow of electric current is proportional to the heat gain or loss at the junction [12].

##### 3.2.2 Seebeck effect

In this process, direct heat is converted to electricity at the junction of various conductors (wire). This requires the generation of voltage along the wire that is subject to the temperature gradient and it results in thermoelectric power (see **Figure 2**) [13].

#### 3.3 Vapor absorption refrigeration systems

The vapor absorption refrigeration system (VARS) comprises the same processes in the vapor compression system (VCS) such as compression, expansion, condensation, and evaporation. In the vapor absorption system, the working fluid used is ammonia, water, or lithium bromide. The refrigerant produces a cooling effect in the evaporator, and heat dissipates to the atmosphere through the condenser. The main difference between the two systems is the suction and compression of the refrigerant in the refrigeration cycle. In the VCS, the compressor sucks the refrigerant from the evaporator and compresses it to high pressure. The compressor also enables the flow of the refrigerant through the whole refrigeration system. In the VAS, the process of suction and compression is carried out by two

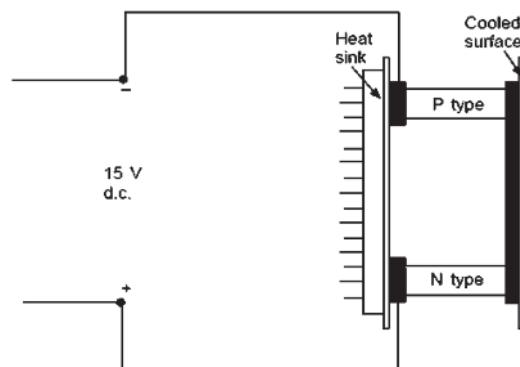

**Figure 2.**  
*Thermoelectric refrigeration systems.*

different devices called the absorber and the generator. The absorber and generator replace the compressor in the VAS (**Figure 3**) [14].

### 3.4 Vortex tube systems

This cooling method is obtainable by the compressed air entering the vortex tube at high pressure through a tangential nozzle, which serves as an accelerator for the flow of air and creates high rotational speed and velocity. The air possesses a whirling motion that resulted in cold and hot air, which discharge through the cold and the hot pipes attached to the vortex tube [15].

### 3.5 Steam ejector refrigeration system

In a steam ejector refrigeration system (SERS), high-pressure steam of 10 bar is employed at a velocity of about 1200 m/s. The water evaporates at 4–7°C for air-conditioning duty was obtained with a steam ejector at low pressures ranging between 8 and 22 mbar. However, SERS' coefficient of performance is lesser than that of the vapor absorption system, and this placed a limit in its application where a large quantity of steam is required (**Figure 4**) [16].

### 3.6 Air expansion refrigeration systems

There is a temperature rise when air is compressed. Thus, the temperature drops when the air is allowed to do work while expanding and is obtained by sensible heat only, which is the basis of the air liquefaction process. The main application for the expansion refrigeration system cycle is in the pressurization of aircraft and air

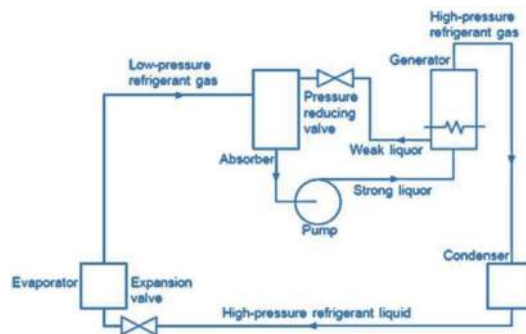

**Figure 3.**  
*Vapor absorption refrigeration systems.*

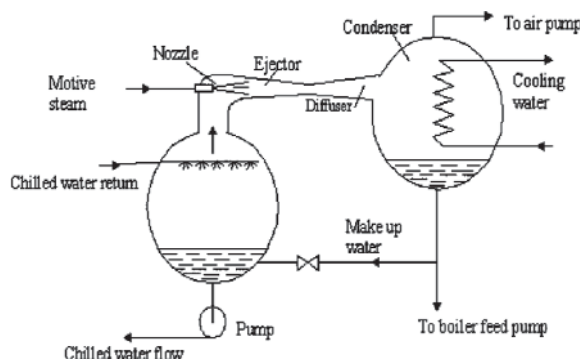

**Figure 4.**  
*Steam jet refrigeration system.*

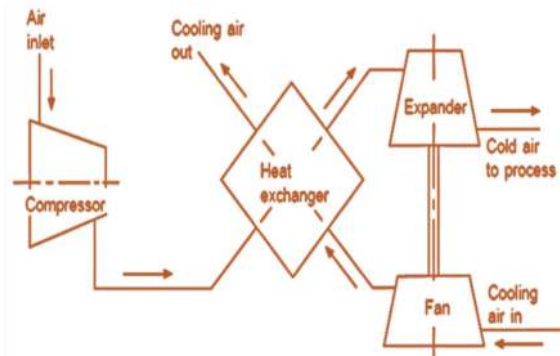

**Figure 5.**  
*Air or gas expansion refrigeration systems.*

conditioning. Also, the turbines used compression and expansion turns at very high speeds to achieve the actual pressure ratios, and as a result, it is noisy. Likewise, the coefficient of performance is lower compare to other refrigeration systems. The normal cycle uses the expansion of the air to drive the first stage of compression, so retrieve some of the input energy (Figure 5) [17].

## 4. Type of air conditioning system

### 4.1 Domestic air conditioning system

#### 4.1.1 The window-type air conditioner

This type of air conditioner has all the components assembled in one compartment. It is often inserted through the wall of a building, but due to the configuration and installation, the hole carved on the building wall weakens the structure over a while. It also provides an opportunity for external factors such as rats and snakes to enter through the small openings on the wall. Though, it is readily available and cheap [18, 19].

#### 4.1.2 Split type air conditioner

The split type of air-conditioning is an upgrade of the window air conditioner with two separate. The indoor unit mainly contains the evaporator, vent, evaporator motor, filter, electric panel, and the outdoor comprised of the compressor, condenser, capacitor, fan blade, electrical panel, accumulator, and expansion valve. This air conditioner is more effective in terms of performance and does not require a sizeable expanse of the hole in the building. Though it is more expensive, the maintenance cost is higher than the window air conditioner [20].

### 4.2 Industrial air conditioning

#### 4.2.1 Standalone air conditioner

It is an industrial-scale air conditioner that comes with different tons in terms of duty. Also, it has two units, indoor and outdoor. This type of air conditioner is higher in capacity compared to the window and split air conditioners. It comes in various sizes depending on the capacity and manufacturer's design. Its limitation is that it occupies space and expensive [19, 21].

#### 4.2.2 Central air conditioner

The central air-conditioner is an improvement of the standalone air conditioner. This air-conditioner found its operations in an extensive environment such as banks, shopping malls, Churches, and Conference centers. It is most effective and works with a network of the ducting system to enable even distribution of cool air across the desired area to be cooled even though it is costly in terms of running cost and maintenance [22, 23].

### 5. Low-temperature technology

Low-temperature technology is achievable through the refrigeration processes, particularly in the vapor compression refrigeration system (VCRS). This process requires heat transfer from the refrigerating space through a heat exchanger known as the condenser. The heat moves to the immediate surroundings, thereby lowering the heating space's temperature and increasing the surrounding temperature [24, 25]. However, the application of VCRS has become a worldwide phenomenon. The VCRS is used to protect perishable items and provide human comfort [26–29]. In designing a VCRS, the refrigerant (working fluid) choice is crucial as it preempts the system's cost, dependability, and safety. Considering various environmental challenges such as global warming and ozone layer depletion, the appropriate selection of refrigerant is required due to the atmospheric greenhouse effect and stratospheric ozone depletion caused by refrigerant emission [21]. The refrigerant is selected based on their safety, thermo-physical and thermodynamics properties, and economic factor [30].

In 1850, ethyl ether became the most prominent refrigerant used in a commercial refrigeration system. Other natural refrigerants such as ammonia, water, carbon dioxide, and gasoline were exploited as heat transfer mediums. Still, they were replaced with sulfur dioxide and methyl chloride because of incompatibility with the system materials. Moreover, at a low cost and good thermodynamic properties, ammonia has an increased coefficient of performance. However, it is toxic, preventing it from being used for domestic purposes [31–33]. Therefore, the search to have better-working fluid with excellent thermal properties used in a refrigeration system has prompted the discovery of halocarbon refrigerants. The halocarbons are synthetic refrigerants, which include chlorofluorocarbon and hydrochlorofluorocarbon refrigerants (HCFCs). They were better alternatives for natural refrigerants because of their high thermal efficiency [34–37]. The chlorofluorocarbon (CFC) refrigerant was discovered in the 1930s with zero explosion risk but later disadvantaged the ozone layer [30]. In 1996, the developed nations successfully phased out the CFC, while the developing countries agreed to cease its application in 2010 [38]. The HCFCs were found as the best short-term alternative replacement for chlorofluorocarbon, but with a global warming potential of 1810. The use of HCFCs will be limited to 2020 and 2030 in developed and underdeveloped countries. Likewise, Du Pont's chemical manufacturer declared that the HCFC substances' production should be ceased but would persist in making it available for existing equipment until their expiry period [39–41].

The emergence of hydrofluorocarbon (HFCs) refrigerants with appropriate thermo-physical and thermodynamic properties have provided opportunities for extensive scale usage at the consumer and commercial levels since the 1990s. This rapid growth and application of HFCs in domestic and mobile refrigeration systems require prompt attention due to their negative effect on global climate [42, 43]. However, hydrofluorocarbon refrigerant (R134a) has zero ODP with a high GWP of 1430, which suggests it is a working fluid that threatens the immediate

surroundings. The international regulatory bodies (Kyoto and Montreal protocols) have called for the banning of pure fluid, posing a threat to climate and environment due to high global warming and ozone depletion [44–46]. But the reduction rate of the pure fluid is subject to review. More so, some limiting factors disannulled halocarbon refrigerants’ application in the heating and air-conditioning industries, such as the enormous energy consumption rate and increased global warming [47]. Furthermore, the Kigali amendment (KA) adoption in 2016 created a platform to generate a phase-out schedule for HFC refrigerants towards the next decades, and if this is achieved, it will contribute positively to the Paris agreement (PA) and to the United Nation Framework Convention on Climate Change (UNFCCC) adopted in 2015, which focuses on keeping the global temperature to less than 2 oC with the enforcement by Nationally Determined Contribution (NDC) for greenhouse gas (GHG) [48–51]. The consistent climate change prompted research towards discovering and applications of eco-friendly refrigerants in the heating and air-conditioning systems that reduce GHG and enhance energy saving [52].

Halogen-free refrigerants (HFRs) are found naturally and have been extensively discovered as an alternative to halocarbon refrigerants in the refrigeration system. They are also referred to as eco-friendly refrigerants with an organic composition of hydrogen and carbon atoms [21]. The European nations use HFRs instead of halocarbon refrigerants because it possesses good thermodynamic properties. Hydrocarbon refrigerant is miscible with mineral oil, which provides a smooth running of the single hermetic reciprocating compressor (SHRC). The working fluid is compatible with the refrigeration system’s elastomeric materials with zero ozone depletion and negligible global warming potential. Also, the HCR refrigerant has a high critical temperature that enhances the domestic refrigerator’s efficiency [53–59]. The HFR is for preserving the environment, but it serves as an energy reduction substance with high energy efficiency in the refrigeration system. Although HFRs was reported flammable [60], this proved to be invisible because of various factors that must be attained before the explosion takes place, which includes:

Refrigerant type	Composition	GWP	ODP	Safety group
HCFC 22 refrigerants				
R22	CHClF <sub>2</sub>	1810	0.055	A1
R124	CHClFCF <sub>3</sub>	609	0.022	A1
R142b	CClF <sub>2</sub> CH <sub>3</sub>	2310	0.065	A2
HFC refrigerants				
R134a	CF <sub>3</sub> CH <sub>2</sub> F	1430	0	A1
R152a	CHF <sub>2</sub> CH <sub>3</sub>	124	0	A2
R125	CF <sub>3</sub> CH <sub>2</sub> F	3500	0	A1
R143a	CF <sub>3</sub> CH <sub>3</sub>	4470	0	A2L
R32	CH <sub>2</sub> F <sub>2</sub>	675	0	A2L
Hydrocarbon refrigerants				
R600a	CH(CH <sub>3</sub> ) <sub>2</sub> CH <sub>3</sub>	3	0	A3
R290	CH <sub>3</sub> CH <sub>2</sub> CH <sub>3</sub>	3	0	A3
R1270	CH <sub>2</sub> CH <sub>2</sub> CH <sub>2</sub>	3	0	A3
R170	CH <sub>3</sub> CH <sub>3</sub>	6	0	A3

**Table 1.** Properties of refrigerants [21, 71].



- i. there must be the presence of an ignition source
- ii. a surface temperature that exceeds 440°C
- iii. release of hydrocarbons is essential, which mix with the appropriate proportion of air [61].

The halogen-free refrigerant is applicable in a closed system with relatively less mass charge. It attains a high level of recognition in the '90s and is used in significant engineering systems such as water dispensers, deep freezers, air-ventilation machines, domestic refrigerators, and industrial refrigeration systems [62, 63].

The refrigerants are classified based on their chemical composition and safety [64]. Refrigerant properties are shown in **Table 1**.

## 6. Environmental effect and economic impact of hydrocarbon refrigerants

Hydrocarbon refrigerants (HCs) such as carbon dioxide, water, ammonia, butane, propane, isobutene, and propylene are commonly used in residential and commercial buildings to attain a cooling effect. However, the HCs refrigerants have found their heating, ventilation, and air conditioning system applications due to their advantages over conventional refrigerants in terms of global warming, ozone depletion, and energy reduction in energy consumption. HC refrigerants do not have any halogen elements in their compound formulation, which enable a safe environment and prevent climate change [59]. Most developed nations have used HCs refrigerant in their refrigeration systems, such as domestic refrigerators, cars, heat pumps, and industrial air cooling systems, etcetera.

The economic implication of hydrocarbon refrigerants is obvious, the price of the compressor that uses HCs is less compared to a compressor that uses HFC, and the mass charge of HC refrigerant is lower compared to HFC refrigerant, which is ratio 1:2 respectively [65]. The reduction in mass charge of isobutane (HC600a) was due its higher value of latent heat or high volumetric capacity [25]. Also, HC refrigerant, when in use, saves more energy compare to HFC refrigerant (see **Figure 6**), and that leads to cost reduction. Moreover, the cooling capacity of a

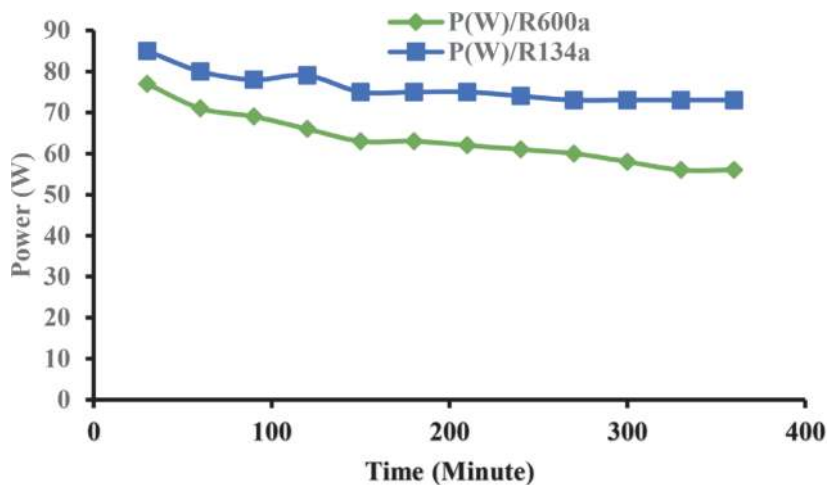

**Figure 6.**  
Correlation between power input for R600a and R134a with time.

Compressor type		Key indicator	Economic analysis
HFC134a	HC600a		
213	186	GWP	32.6 €/t
185	158	SO <sub>2</sub>	7.4 €/kg
41	36	NO <sub>2</sub>	2.3 €/kg
169	148	PM10	17 €/kg
608	527	Total	

**Table 2.** Economic analysis of emissions for compressor HC600a and HCF134a [66].

refrigeration system can be enhanced using the cryogenic refrigeration approach. According to [66], the economic analysis of emissions for compressor that uses HC600a and HFC134a refrigerants for 15 years lifecycle evaluation (LCE) was taken, despite of wear coefficients of the lubricant and lower friction rate the energy reduction rate was 6.54% lower when using HCF134a. The evaluation of environmental cost was based on key environmental indicators, GWP (Carbon dioxide/CO<sub>2</sub>), SO<sub>2</sub>, NO<sub>2</sub> and PM10. See **Table 2** for details.

## 7. Cryogenic refrigeration cooling system

Cryogenic refrigeration generates low temperatures far below the average temperature produced by a simple vapor compression refrigeration system. It is used to determine temperature range from  $-150^{\circ}\text{C}$  to  $-273^{\circ}\text{C}$ , and the gases associated with cryogenic are Nitrogen (N<sub>2</sub>), Oxygen (O<sub>2</sub>), Helium (He), and Hydrogen (H<sub>2</sub>), which boiled below  $-150^{\circ}\text{C}$ , while other refrigerants have their boiling point above  $-150^{\circ}\text{C}$ . In Engineering, the role of cryogenic includes electronics, rocket propulsion system, food preservation, nuclear engineering application, mechanical design, and biological application. Furthermore, the cryogenic approach of producing low temperature is used for commercial application and this achievable by different methods such as cascade refrigeration and multistage compressor [67, 68].

### 7.1 Cascade refrigeration

This system was first introduced in 1877 by Pictet, where he used for the liquefaction of oxygen (O<sub>2</sub>). There are two or three vapor compression systems involved, and for it to generate low temperature, various kinds of refrigerants were employed at the different circuits. It has application in medical and industrial systems, and one typical example is the preservation of blood in the blood bank because blood requires a temperature as low as  $-80^{\circ}\text{C}$  [69].

### 7.2 Multistage

This type of system has higher volumetric efficiency, which results in increased compressor capacity compared to single-state compression. The cooling effect in a multistage system (MS) is obtainable by using two or more refrigerating spaces at various temperatures. The MS is represented in **Figure 7**. There is a limitation on the lowest temperature that can be attained using this method due to the usual

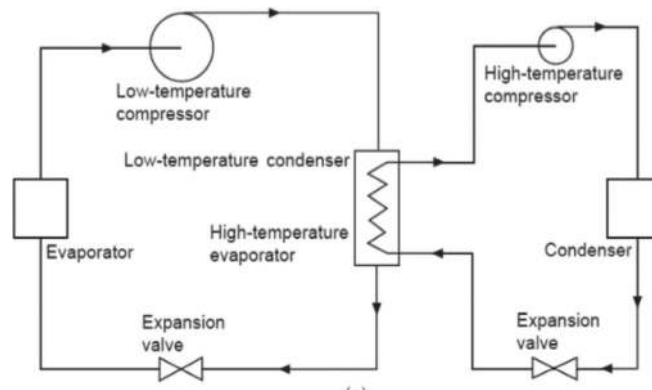

**Figure 7.**  
*Systematic diagram of the multistate system.*

boiling point of the refrigerant. Thus, this system is not appropriate for the production of cryogenic temperature [70].

## **8. Comparison between cryogenic and refrigeration system using isobutane as refrigerant**

From the description of the cryogenic refrigeration system (CRS), it is visible that,

- i. It can be used for commercial purposes, while a refrigeration system with isobutane is often used for domestic applications and small-scale businesses.
- ii. It has a temperature range between  $-150^{\circ}\text{C}$  to  $-273^{\circ}\text{C}$ , while the system using isobutane does not have such a low temperature because it has a boiling point above  $-150^{\circ}\text{C}$ .
- iii. It can use different refrigerant fractions simultaneously, while the isobutane refrigeration system made use of one type of refrigerant at a time.
- iv. In terms of size, CRS is larger than the system that uses isobutane due to its volumetric capacity and work done.

However, this study focused on the importance, properties, challenges, limitations, and refrigerants' applications in the domestic refrigeration system. The refrigeration system's heat transfer fluid (refrigerant) determines the overall performance of the system. More so, the refrigerant serves as the heat transfer medium, while the refrigerant type enables the prediction of a suitable refrigerant to be used in the vapor compression refrigeration system. This work's case study is an ideal system using isobutane (R600a) and hydrofluorocarbon (R134a) as refrigerants. And comparisons were carried out to investigate their performance characteristics.

### **8.1 Solubility/miscibility of lubricant**

The heat transfer within the heat exchanger (H.E) of the refrigeration system is enhanced by the lubricant type used in the process. However, the solubility of the

working fluid in the lubricant improves the heat transfer due to a reduction in the oil's viscosity, which increases the oil fluidity and reduces the negative impact of the heat transfer within the heat exchanger [21]. Therefore, the newly manufactured lubricant is recommended to operate a refrigeration system that uses hydrofluoro-olefins, hydrocarbon, and hydrofluorocarbon blend as working fluid is polyol-ester (POE) oil. It possessed better lubricating properties than conventional oils. Thus, the refrigerant effect becomes more visible on the heat transfer rate within the vapor compression refrigeration system as the appropriate lubricant is charged into the compressor [71].

## **8.2 Procedures for vapor compression refrigeration system analysis**

The system has some essential components through which the thermodynamic properties were measured using various mechanical devices on the vapor compression refrigeration system. These components include a single hermetic compressor, evaporator, standard parallel tube condenser, and capillary tube, as shown in **Figure 8**.

- The vapor compression refrigeration system is positioned for an operation as displayed in **Figure 8**.
- Digital weighing balance was used to measure the refrigerant mass charge into the system.
- The temperature sensors were connected to each of the cardinal points of the refrigeration system.
- Pressure gauge was fixed to the compressor suction and discharge points.
- Power meter was connected to determine the power input to the compressor



**Figure 8.**  
*Prototype of the vapor compression system.*

- A vacuum pump was introduced intermittently to trap the gas and moisture content within the system to prevent clogging
- Digital halogen leakage detector was used to detect leakages along the pipeline.
- The system was allowed to run, and data were captured at an interval of 30 minutes.
- Acquired data were computed for analysis, the performance characteristics of the VCRS that is refrigerating effect, the coefficient of performance, and the compressor work under the ambient temperature of 29°C were determined.

### 8.3 The basic equation for standard vapor compression system

The following expression explains the relationship between the heat input and output of a refrigeration system. The availability of a pure substance can be defined by Eqs. (1)–(6) [25, 40, 47], assuming there is an insignificant change in kinetic and potential energy across the four essential components [30].

Heat absorbed in the evaporator

$$Q_e = \dot{m}(h_{e1} - h_{e4}) \text{ in kW} \quad (1)$$

Where,

$Q_e$  = heat of evaporator.

$h_{e1}$  = specific enthalpy of vapor existing evaporator in kJ/kg.

$h_{e4}$  = specific enthalpy of a cooled refrigerant entering evaporator in kJ/kg.

$\dot{m}$  = refrigerant mass flow rate in kg/s.

Compressor work

$$W_c = \dot{m}(h_{c2} - h_{c1}) \text{ in kW} \quad (2)$$

Where,

$W_c$  = compression work input.

$h_{c2}$  = specific enthalpy of vapor exiting compressor in kJ/kg.

$h_{c1}$  = specific enthalpy of vapor entering compressor in kJ/kg.

$\dot{m}$  = refrigerant mass flow rate in kg/s.

Coefficient of performance

$$COP = \frac{\dot{m}(h_{e1} - h_{e4})}{\dot{m}(h_{c2} - h_{c1})} \quad (3)$$

Where,

$COP$  = coefficient of performance.

$Q_e$  = heat of evaporator in kJ/kg.

$W_c$  = Compressor work done in kJ/kg.

$\dot{m}$  = mass flow rate of the refrigerant in kg/s.

Refrigerating effect

$$R.E = COP \cdot W_c \quad (4)$$

Where,

$R.E$  = refrigerating effect.

$COP$  = coefficient of performance.

$W_c$  = compressor work done on the working fluid.

Heat rejected by the condenser

$$h_{cond} = \dot{m}(hc_2 - hc_3) \text{ in kW} \quad (5)$$

Where,

$h_{cond}$  = heat of condenser.

$hc_2$  = specific enthalpy of vapor entering condenser in kJ/kg.

$hc_3$  = specific enthalpy of subcooled refrigerant exiting condenser in kJ/kg.

Refrigerant mass flow rate.

The refrigerant mass flow rate is defined as the ratio of the refrigerating effect to the enthalpy change in the evaporator.

$$\text{Refrigerant Mass flow rate } (\dot{m}) = \frac{\text{cooling load}}{h_{e1} - h_{e4}} \text{ in kg/s} \quad (6)$$

## 9. Result and discussions

**Figures 6, 9, and 10** explain the thermodynamic effect that occurs in the refrigeration system. **Figure 9** shows the system's evaporating temperature (ET) when working with R600a and R134a refrigerants. The system attained its ET, the minimum operating temperature of  $-26^\circ\text{C}$  while working with R600a in 3 hours compared to when the system worked with R134a and attained ET of  $-22^\circ\text{C}$  in 5 hours.

**Figure 6** displayed the hermetic compressor's power when the system worked with R600a and R134a refrigerant. It was clear that the system's energy consumption rate using R600a was 23.3% lower than when the system worked with R134a. The result obtained means the refrigeration system performed excellently with R600a refrigerant at ET of  $-26^\circ\text{C}$ .

**Figure 10** shows the domestic refrigeration system's coefficient of performance when working with R600a and R134a refrigerants. The result indicates that the system has a better working operation when working with R600a refrigerant. That is, the COP increases by 27.1% compared to when it worked with R134a.

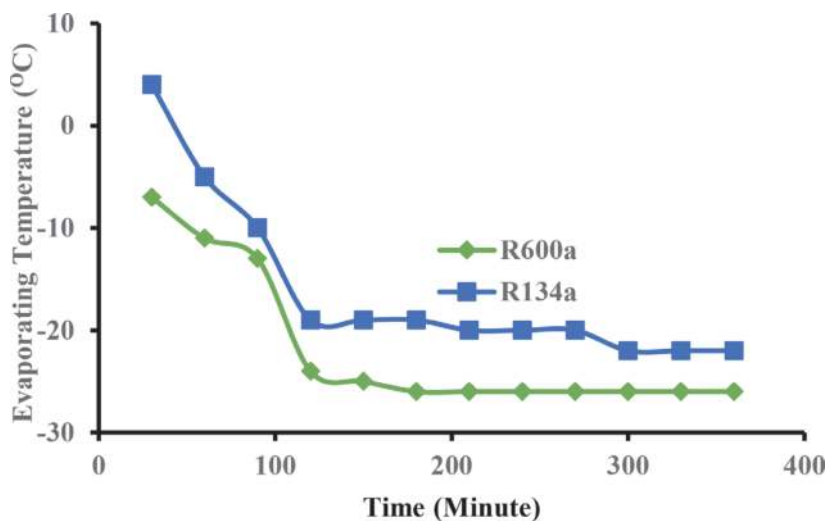

**Figure 9.** Variation ET of R600a and R134a with the time taken.

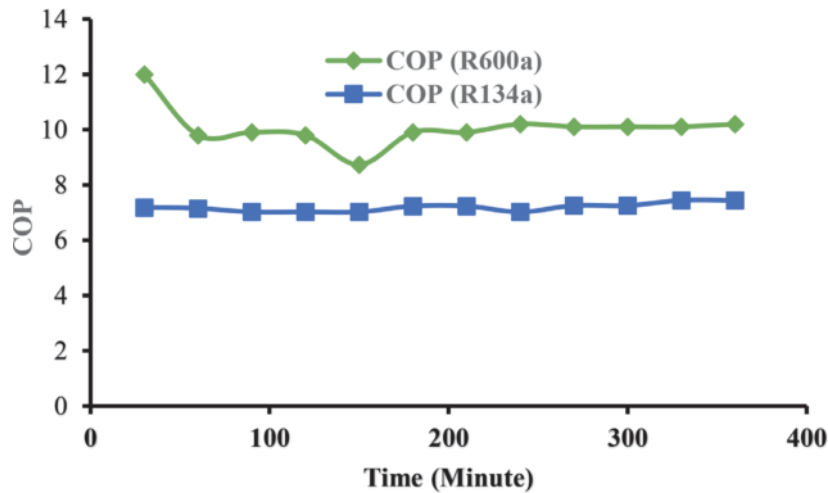

**Figure 10.**  
*Coefficient of performance with time.*

## 10. Conclusion

This study provides access for the selection of working fluid (refrigerant), which would be appropriate for a domestic refrigerator and air-conditioning system. The effect of the working fluid contributes to the exchange rate of heat transfer in the cooling system. It also enables the computation of the system's performance characteristics (PC), which primarily predicting the system's workability and the evaporator temperature, that is, the minimum temperature required for the refrigeration system to be satisfied as efficient. The system analysis will serve as a standard measure for the procurement of any refrigeration system. Furthermore, the performance of a refrigeration system depends on the working fluid that runs through it. Therefore, based on the comparative performance of R600a and R134a refrigerants in the vapor compression refrigeration system, the working fluid dramatically impacts the overall efficiency and refrigeration effect of the cooling system, with R600a a preferable refrigerant. The use of isobutane secures the surroundings from global warming and ozone depletion and improves energy conservation.

## 11. Recommendation

The recommendations are based on the system prototype, a specific refrigeration system suitable for Nigeria, and other areas in the perspective of the global economy.

Prototype of the refrigeration system with relevant costing based on the economy of Nigeria. The refrigeration system made from locally sourced materials was used (see **Table 3**).

Isobutane was used as a replacement for a conventional refrigerant because of its thermodynamic properties. The refrigerant has a negligible global warming potential, zero ozone depletion potential, miscible with oil, and high critical temperature, which enhance the refrigeration system's performance [72]. The price of the hydrocarbon refrigerant (isobutane) and the refrigerator's component was suitable to employ within Nigeria. The vapor compression refrigeration system is recommended for household usage because it works using non-toxic refrigerant, as in the vapor absorption system. Likewise, thermoelectric refrigeration is less

S/N	Component	Specification	Cost (#)
1	Marine board	Plywood	15,000
2	Aluminum	Tin foil (<0.2 mm)	10,000
3	Styrofoam	EPS-thermal	3,000
4	Hermetic sealed compressor	1/12 (60–70 W)	13,000
5	Condenser	Air cooled type	1,900
6	Evaporator	1/4 Copper pipe	7,500
7	Capillary tube	Copper tube type	500
8	Refrigerant	R600a	600

**Table 3.**  
*Materials used for the construction of the refrigerator with cost in Nigeria.*

efficient compared to VCRs [73, 74]. Since most developing nations have adapted isobutane, the recommendation is made for the under-developed countries to use hydrocarbon refrigerant in their refrigeration system as it has been proved eco-friendly. The use of HCs refrigerant would reduce the overall price of the refrigerator and maintenance cost in terms of power consumption because isobutane refrigerant saves energy compared to the conventional refrigerant, but this is subject to the climate conditions of various countries [75].

The overviewed recommendation for other regions in the world from the global economy perspective was that there are approximately five different climates: temperate, dry, tropical, polar, and continental. The regions with a high degree of temperature can use conventional refrigerants if they could not meet the conditions for maintaining hydrocarbon refrigerant [21]. However, countries with cool and cloudy climates could subscribe to hydrocarbon refrigerants because their temperatures are under control. Furthermore, the cost evaluation for the prototype was 15% lower than the recent cost price of a domestic refrigerator of the same volume capacity and power rating (see **Table 3**).

## **Acknowledgements**

The authors acknowledge the Covenant University management and Centre for Research Innovation and Discoveries (CUCRID) contribution to support the implementation of this work.

## **Conflict of interest**

The authors declare there are no conflicts of interest.



## **Author details**

Solomon O. Banjo<sup>1,2\*</sup>, Bukola O. Bolaji<sup>2</sup>, Oluseyi O. Ajayi<sup>1</sup> and Olatunde A. Oyelaran<sup>2</sup>

1 Department of Mechanical Engineering, Covenant University, Ota, Ogun State, Nigeria

2 Department of Mechanical Engineering, Federal University, Oye-Ekiti, Ekiti State, Nigeria

\*Address all correspondence to: [solomon.banjo@covenantuniversity.edu.ng](mailto:solomon.banjo@covenantuniversity.edu.ng)

## **IntechOpen**

---

© 2021 The Author(s). Licensee IntechOpen. This chapter is distributed under the terms of the Creative Commons Attribution License (<http://creativecommons.org/licenses/by/3.0>), which permits unrestricted use, distribution, and reproduction in any medium, provided the original work is properly cited. 

## References

- [1] Banjo, S.O., Ajayi, O.O., Bolaji, B.O., Emeteri, M.E., Fayomi, O.S.I., Udoeye, N. E., Olatunde, A.O., Akinlabu, K. Evaluation analysis of a developed solar refrigerator using conventional refrigerant for rural and medical applications. IOP Conf. Ser.: Earth and Environmental Science. 2021; 665, 012028.
- [2] Donald, B. and Nagengast. Heat and cold mastering the great indoors. ASHARE, Inc. 1791. Tullie circle NE Atlanta, GA 30329. 1994; ISBN: 1-883413-17-6.
- [3] George C. and Briley P.E. A history of refrigeration. AHARE Journal. 2004; 31-34.
- [4] Austin, N. and Senthil, K.N. (2012). Thermodynamic optimization of household refrigerator using propane-butane as mixed refrigerant, international journal of engineering research and applications. 2012; 2, 6: 268-271.
- [5] Makhnatch, P, Mota-Babiloni, A. and Rogstam, J. Retrofit of lower GWP alternative R449A into an existing R404A indirect supermarket refrigeration system, International Journal of Refrigeration. 2017; 26: 184-192.
- [6] Sadollah, E., Anwar Gavili, M.L., Taghi, D., Iraj, H. and Jamshid, S. New Class of Coolants: Nanofluids, Cutting Edge Nanotechnology, Dragica Vasilevska (2nd ed.). 2010; 12-28.
- [7] Desai, P.S. Modern Refrigeration and Air Conditioning for Engineer's (Principle, Practices and Application), 1st Ed. 2007; Khanna Publishers, 2-B, Nath Market, Nai Sarak, Delhi-110006.
- [8] Yusuf, A.C. and Michael, A.B. Thermodynamics an Engineering Approach, 7th Edition, 20, 2011; McGraw-Hill Publishers, 1221 Avenue of Americas, New York NY100.
- [9] Jingyi, M.O., Robert, D. G., McCartney, G., Enyu, G., Bent, O.J., Gerard van Dalen Schuetz, O.P., Rockett, P., Lee, P.D. Ice crystal coarsening in ice cream during cooling: A comparison of theory and experiment. 2019; 9, 6: 321, DOI:10.3390/cryst9060321
- [10] Duan, Z., Zhan, C., Zhao, X., Dong, X. Experimental study of a counter-flow regenerative evaporative cooler. Building and Environment. 2016; 104: 47-58, DOI:10.2016/j.buidenv.2016.04.029.
- [11] Porumb, B., Unguresan, P., Tutunaru, L.F., Serban, A., Balan, M. A review of indirect evaporative cooling technology. Energy Procedia. 2015; 85: 461-471, <http://creativecommons.org/licenses/by-nc-nd/4.0/>
- [12] Kumar, A. and Devesh, K. Design and development of solar thermoelectric air cooling system. Imperial Journal of Interdisciplinary Research. 2016; 2, 6: 1529-1533.
- [13] Shetty, N., Soni, L., Manjunath, S. and Rathi, G. Experimental analysis of solar powered thermoelectric refrigerator. International Journal of Mechanical and Production Engineering. 2016; 4, 8: 1-4.
- [14] Chakraborty, J. and Bajpai, V.K. A review paper on solar energy operated vapour absorption system using Libr-H<sub>2</sub>O. International Journal of Engineering Research and Technology. 2013; 2, 8: 1-3.
- [15] Bornare, T., Badgujar, A. and Natu, P. Vortex tube refrigeration system based on compressed air. International of Mechanical Engineering and Technology. 2015; 6, 7: 97-102.
- [16] Kittrattan B., Aphornratana S., Thongtip T. The performance of steam

- ejector refrigeration system based on alternative analysis. *Energy Procedia*. 2017; 482-487, 10.2016/j.egypro2017.10.230
- [17] Shuo, Z., Xianmin, G., Liang Z. Experimental study of air cycle refrigeration system for quick-freezing. *International Conference on Cooling and Heating Technologies*. 2012; 1-9, <http://www.researchgate.net/publication/270823569>
- [18] Razzaq, M.A., Khan, M.M., Ahamed, J.U. Irreversibility of analysis of a split type air conditioner using R600a as refrigerant. *International Conference of Mechanical Engineering and Renewable Energy*. 2017; 1-6.
- [19] Sawant, A.P., Agrawal, N., Nanda, P. Performance assessment of an evaporative cooling-assisted window air conditioner. *International Journal of Low-Carbon Technologies*. 2012; 7: 128-136.
- [20] Raiyan, M.F., Ahamed, J.U., Rahman, M.M., Salam, M.A. Performance and exergetic investigation of a domestic split air conditioner using blends of R22 and R290. *International Journal of Automotive and Mechanical Engineering*. 2017; 14, 2: 4125-4139.
- [21] Bilter. Refrigerant Report. Bilter International, Latest Edition. 2020; 71065 Sindelfingen, Germany.
- [22] Homod, R.Z. Review on HVAC system modelling types and the shortcomings of their application. *Journal of Energy*. 2013; 1-10, DOI: 10.1155/2013/768632.
- [23] Tashtoush, B., Tahat, M., Al-Hayajneh, A., Mazur, V.A. Probert, D. Thermodynamic behavior of an air conditioning system employing combined evaporative-water and air cooler. *Applied Energy*. 2001; 70: 305-319.
- [24] Bolaji. Theoretical assessment of new low global warming potential refrigerant mixtures as eco-friendly alternatives in domestic refrigeration systems, *Scientific African*. 2020; 10, e00632: 1-11.
- [25] Banjo, S.O., Bolaji, B.O., Ajayi, O.O., Olufemi, B.P., Osagie, I. and Onokwai, A.O. Performance enhancement using appropriate mass charge of R600a in a developed domestic refrigerator, *IOP Conf. Ser.: Earth and Environmental Science* 2019; 331, 1: 1-8.
- [26] Basha, T.M., Ranganna, H., Yadav, G. M.P. Optimum length of a condenser for domestic vapor compression refrigeration system, *International Journal of Science, Engineering and Technology Research*. 2015; 4, 2: 277-281.
- [27] George, C. and Briley, P.E. A history of refrigeration. *AHARE Journal*. 2004; 31-34.
- [28] Adekunle, A., Arowolo, T.A., Adeyemi, O.M., Kolawole, O.A. Estimation of thermal comfort parameters of building occupants based on comfort index, predicted mean vote and predicted percent of dissatisfied people in the northern west zone of Nigeria. *International Journal of Advanced in Engineering and Management*. 2020; 2, 5: 809-826.
- [29] Orhewere, B.A., Oluseyi, O. A., Solomon, O.B. and Ajayi A.A. Data on the no-load performance analysis of a tomato postharvest storage system (data in brief), *IOP Conference Series Material Science and Engineering*. 2017; 13: 667-674.
- [30] Bhavesh, A.K., Mohod, S.A. and Dhawade, M. Effect of different refrigerants on vapor compression refrigeration system—A review. *International Journal of Engineering Development and Research*. 2016; 4, 2: 329-335.
- [31] McMullan, J.T. Refrigeration and environmental issues and strategies for

the future. *International Journal of Refrigeration*. 2002; 25: 89-99.

[32] Ibhabode, O., Adehunle, A.A., Banjo, S.O., Atakpu, O.D. Thermophysical, electrical and mechanical characterizations of normal and special concrete: A holistic-empirical investigation of pre-qualification and quality-control of concrete. *Journal of Physics*. 2019; 1378: 1-76, doi:10.1088/1742-6596/1378/4/042100.

[33] Ishak, F., Dincer, I., Zamfirescu, C. Thermodynamics analysis of ammonia-fed solid-oxide fuel cell. *Journal of Power Sources*. 2012; 202: 157-165.

[34] Bolaji, B.O. Experimental study of R152a and R32 to replace R134a in a domestic refrigerator. *Energy*. 2010; 35: 3793-3798.

[35] Akash, B.A. and Said, S.A. Assessment of LPG as a possible alternative to R-12 in domestic refrigerators. *Energy Conversion and Management*. 2003; 44:381-388.

[36] Vaibhav, J. Kachwaha, S.S. and Mishra, R.S. Comparative performance study of vapour compression refrigeration system with R22/R134a/R410A/R407C/M20. *International Journal of Energy and Environment*. 2011; 2, 2: 297-310.

[37] Ranendra, R. and Bijan, K.M. First law and second law analysis of mechanical vapour compression refrigeration system using refrigerants CFC12, R134a, R290. *International Journal of Current Engineering and Technology*. 2014; 3: 191-195.

[38] Fernandez-Seara, J., Uhia, F.J., Diz, R. and Dopano, J.A. Vapour condensation of R22 retrofit substitutes R417A, R422A and R422D on Cu.Ni turbo C tubes. *International Journal of Refrigeration*. 2010; 33: 148-157.

[39] Eastop and McConkey, *Applied Thermodynamics for Engineering Technologist*. 2009; New Delhi 110 017, Indian.

[40] Banjo, S.O., Bolaji, B.O., Osagie, I., Fayomi, O.S.I., Fakekinde, O.B., Olayiwola, P.S., Oyedepo, S.O. and Udoye, N.E. Experimental analysis of the performance characteristics of an eco-friendly HC600a as a retrofitting refrigerant in a thermal system, *Journal of Physics*. 2019; 1378, 4: 1-8.

[41] Bolaji, B.O. Selection of environment-friendly refrigerants and the current alternatives in vapour compression refrigeration system. *Journal of Science and Management*. 2011; 1, 1: 22-26.

[42] Dalkilic, A.S. and Wongwises S. A performance comparison of vapour compression refrigeration system using various alternative refrigerants. *International Communication in Heat and Mass Transfer*. 2010; 7: 1340-1349.

[43] Ajayi, O.O., Useh, O.O., Banjo, S.O., Owoeye, F.T., Attabo, A., Ogbonnaya M., Okokpujie, I.P. and Salawu, E.Y. Investigation of the heat transfer effect of Ni/R134a nanorefrigerant in a mobile hybrid powered vapour compression refrigerator. *IOP conference series. Materials Science and Engineering*. 2018;391: 1-8.

[44] Reddy, D.V.R., Bhramara, P., Govindarajulu, K. Performance analysis of domestic refrigerator using hydrocarbon refrigerant mixtures with ANN and fuzzy logic system. *International Conference Numerical Heat Transfer and Fluid Flow*. NIT; 19-21 January 2018; Warangal, India: p. 1-7

[45] UNEP, United Nation Environment Program, *Handbook for International Treaties for Protection of Theozone Layers*, 5th ed. 2003; Narobi, Kenya.

- [46] Adekunle, A., Osagie, I., Ibadode, A.P., Caesar, S.M. Assessment of carbon emissions for the construction of buildings using life cycle analysis: Case study of Lagos state. *International Journal of Engineering Research and Advance Technology*. 2020; 6, 8: 1-11.
- [47] Prakash, U, Vijavan, R. and Vijay, P. Energy and exergy analysis of vapour compression system with various mixtures of HFC/HC. *International Journal of Engineering, Management and Applied Sciences*. 2016; 4, 1: 40-48.
- [48] Tashtoush, B. Tahat, M. and Shudeifat, M.A. Experimental study of new refrigerant mixtures to replace R-12 in domestic refrigerator. *Applied Thermal Engineering*. 2002; 22: 495-506.
- [49] Somchai, W. and Nares, C. Experimental study of hydrocarbon mixtures to replace HFC-134a in a domestic refrigerator. *Energy Conversion and Management*. 2005; 46: 85-100.
- [50] Sekhar, S.J. and Lal, D.M. HFC134a/HC600a/HC290 mixture a result for CFC-12 system, *International Journal of Refrigeration*. 2005; 28: 725-743.
- [51] Dreyfus, G., Borgford-Parnell, N., Fahey, D.W., Motherway, B., Peter, T., Piccolotti, R., Shah, N., Xu Y. Assessment of climate and development benefits of efficient and climate-friendly cooling. 2020; 1-89.
- [52] Mohanraj, M., Jayaraj, S. and Muraleedharan, C. Environment friendly alternatives to halogenated refrigerants—A review. *International Journal of Greenhouse Gas Control*. 2009; 3: 108-119.
- [53] Peyyala, A and Sudheer, NVVS. Experimental investigation of COP using hydrocarbon refrigerant in a domestic refrigerator. *IOP Conference Series. Materials Science and Engineering*. 2017; 225: 012236.
- [54] Sanket, B. Substitution of non-ecofriendly refrigerants by hydrocarbon refrigerants: A review. *International Journal of Advance in Science Engineering and Technology Aurangabad*. 2016; 2: 122-125.
- [55] Kundu A., Kumar, R. and Gupta, A. Performance comparison of zeotropic and azeotropic refrigerants in evaporation through inclined tubes. 11th international conference on mechanical engineering, ICME, *Procedia Engineering*. 2014; 90: 452-458.
- [56] Qureshi, M.A. and Bhatt, S. Comparative Analysis of COP using R134a & R600a refrigerant in domestic refrigerator at steady state condition. *International Journal of Science and Research (IJSR)*, Prestige Institute of Engineering and Science. 2014; 3, 12: 935-939.
- [57] Ahamed, J. U, Saidur, R, Masjuki, H. H. and Sattar, M.A. An analysis of energy, exergy and sustainable development of a vapor compression refrigeration system using hydrocarbon. *International Journal of Green Energy*, 2012; 9, 7: 702-717.
- [58] Banjo, S.O., Fayomi, O.S.I., Atayero, A.A.A., Bolaji, B.O., Dirisu, J.O., Okeniyi, J., Emetere, M.E., Olorunfemi, B.J., Owoeye, T. Effect of fins spacing on the performance evaluation of a refrigeration system using LPG as refrigerant. *IOP Conf. Ser.: Earth and Environmental Science*. 2021; 665, 012030.
- [59] Harby, K. Hydrocarbon and their mixtures as alternative to environmental un-friendly halogenated refrigerants: An updated review. *Renewable and Sustainable Energy Reviews*. 2017; 73: 1247-1264.
- [60] Sattar, M.A., Saidur, R. and Masjuki, H.H. Performance investigation of domestic refrigerator using pure hydrocarbons and blends

hydrocarbons as refrigerants. World Academic of Science Engineering and Technology. 2007; 5: 223-228.

[61] Bolaji, B.O. and Huan, Z. Ozone depletion and global warming: Case for the use of natural refrigerant—A review. *Renewable and Sustainable Energy Reviews*. 2013; 18: 49-54.

[62] ASHARE, Air-Conditioning and Industry Refrigerant: Refrigeration Selection Guide. The Australian Institute of Refrigeration, Air-Conditioning and Heating (AIRAH). 2003; Australia.

[63] Dhamneya, A.K., Rajput, S.P.S and Singh, A. Comparative performance analysis of ice plant test rig with TiO<sub>2</sub>-R-134a nano refrigerant and evaporative cooled condenser. *Case Studies in Thermal Engineering*. 2018; 11: 55-61.

[64] ASHRAE, Designation and Safety Classification of Refrigerant. American Society of Heating, Refrigerating and Air-conditioning Engineers, Atlanta, GA, USA; 2001.34.

[65] Bolaji, O.O. Energy performance of ecofriendly R-152a and R600a refrigerants as alternative to R134a in vapour compression refrigeration system. *Analele UniversitaTii “Eftimi Murgue” Resita*. 2014; 1: 354-367.

[66] Garland N.P. and Hadfield M. (2005). Environmental implication of hydrocarbon refrigerants applied to the hermetic compressor. *Materials and Design*, 26, 578-586.

[67] Raut, P.D. Study of refrigeration system for achieving cryogenic temperature. *International Journal of Science and Research*, 2017; 6, 5: 1444-1448.

[68] Mokhatab, S. and Poe, W.A. Handbook on Natural Gas Transmission and Processing. Gulf Professional Publishing. 2012; Burlington, MA, USA.

[69] Senthilkumar, D. Influence of cryogenic treatment on TiC nanopowder in R600a and R290 refrigerant used in vapor compression refrigeration system. *International Journal of Air Conditioning and Refrigeration*. 2019; 27, 4: 155040

[70] Kalantar-Neyestanaki, H., Mafi, M., Ashrafizadeh, A. A novel approach for operational optimization of multi-stage refrigeration cycles in gas refineries. *International Journal of Refrigeration*. 2017; 80: 169-181.

[71] UNEP/ASHRAE. Update on new refrigerants designations and safety classification. 2020; UNEP/ASHRAErefrigerantfactsheet.[https://www.ashrae.org/file%20library/technical%20resources/refrigeration/factsheet\\_ashrae\\_english-20200424.pdf](https://www.ashrae.org/file%20library/technical%20resources/refrigeration/factsheet_ashrae_english-20200424.pdf).

[72] Abas, N., Kalair, A.R., Khan, N., Haider, A., Saleem, Z. (2018). Natural and synthetic refrigerant, global warming: A review. *Renewable and Sustainable Energy Reviews*, 90, 557-569.

[73] Shetty, N., Soni L., Manjunath S., Rathi G. Experimental analysis of solar powered thermoelectric refrigerator. 2016; 4, 8: 99-102.

[74] Pearson, A. Ammonia as a refrigerant. International Institute of Refrigeration, 2008; Paris France.

[75] Ciconkov, R. Refrigerants: There is still no vision for sustainable solution. *International Journal of Refrigeration*, 2018; 86: 441-448.