

Chapter

Application of Variable Compression Ratio VCR Technology in Heavy-Duty Diesel Engine

Paweł Woś, Krzysztof Balawender, Mirosław Jakubowski, Artur Jaworski, Paulina Szymczuk and Adam Ustrzycki

Abstract

The chapter presents the application of variable compression ratio VCR technology for an internal combustion engine. The engine's overall construction has been designed as the deep reconfiguration of liquid-cooled, heavy-duty diesel engine of type IFA 4 VD 14,5/12-1 SRW. An eccentric shaft-based sliding mechanism has been used for changing position of engine cylinder head assembly. By ensuring a high stiffness of the engine layout together with additional sliding mechanism, the combustion chamber volume of the engine can be changed precisely without changing the displacement of the cylinders. In result, the engine compression ratio can be continuously varied during normal engine operation from the value of 19:1 down to 9:1.

Keywords: heavy-duty diesel engine, compression ratio, variable compression ratio technology, eccentric mechanism, internal combustion engine

1. Introduction

The desire to limit the adverse external effects associated with the development of motorization and transport, mainly based on the reciprocating internal combustion engine as the primary power source, reveals primarily with limitation the allowable level of emissions of harmful substances in the exhaust gases, that is, carbon monoxide, CO; hydrocarbons, HC; nitrogen oxides, NO_x; and particulate matter, PM. Moreover, in the perspective of growing global warming phenomenon and dropping resources of liquid fuels, particular attention is paid to the reduction of fuel consumption and thus CO₂ emission. Unfortunately, the physical and chemical rules of working processes in piston engines do not allow to meet all the above requirements in a simple manner. Despite significant progress made in recent years, further improvement of the ecological and energetic parameters of reciprocating engines requires further changes in their design, covering practically all functional systems.

One of the more effective paths, although at the current stage of development is still having many technical and operational difficulties, is the construction of engines in which the compression ratio becomes a regulation parameter and can be

changed continuously in a wide range and relatively short time. In a conventional engine, the compression ratio—the ratio of the smallest to the largest cylinder volume at piston top dead center positions—is constant and determined by the geometry of the cylinder and crank mechanism. The new technology called variable compression ratio, and marked with the VCR symbol, completely changes the previously unchanged feature of the engines. Many companies have noticed significant potential hidden in variable compression systems and focused their entire attention on finding ways to apply and use this feature. Therefore, over the last years, there has been a growing interest in this type of innovative construction.

1.1 Potential application area of VCR technology

The origination of the idea of variable compression ratio was the desire to use for the engine supplying fuels with different properties; it is the so-called flex-fuel capability. Although it is still a valuable property, currently in the development of internal combustion engines, a special emphasis is placed on reducing fuel consumption, and thus CO₂ emissions, as well on reducing the emission of harmful exhaust components—carbon monoxide, hydrocarbons, nitrogen oxides, or particulates.

Global automotive industry as well science and research institutions involved in the development of VCR technology say about the potential for reducing fuel consumption by using a variable compression ratio in engines of different capacity. Significant economic benefits are particularly visible when variable compression ratio technology is used for high-power engines. It is significant also if these are naturally aspirated or boosted engines with direct injection (DFI) and variable-controlled valve actuation (VVA). **Figure 1** illustrates the potential benefits for the individual and combined use of these solutions.

Significantly, greater benefits in the field of fuel economy and engine ecology can be obtained by combining the VCR and VVA variable valve actuation systems (**Figure 2**). The use of these systems allows, for example, the implementation of the Atkinson working cycle and the using engines of smaller dimensions with maintained high operational parameters, that is, according to the idea of “ultra-downsizing.”

“Downsizing” is a relatively new development trend of piston engines, which gives a response to strong pressure on reducing fuel consumption and improving the overall engine efficiency. The idea of downsizing is to reduce the cubic capacity of the powerdrives and increase the power ratio, mainly by using still higher and

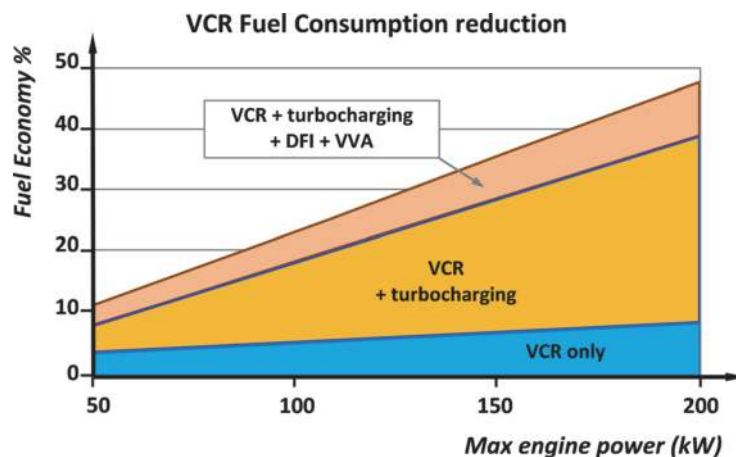

Figure 1. The predicted increase in engine fuel economy with using VCR technology [1].

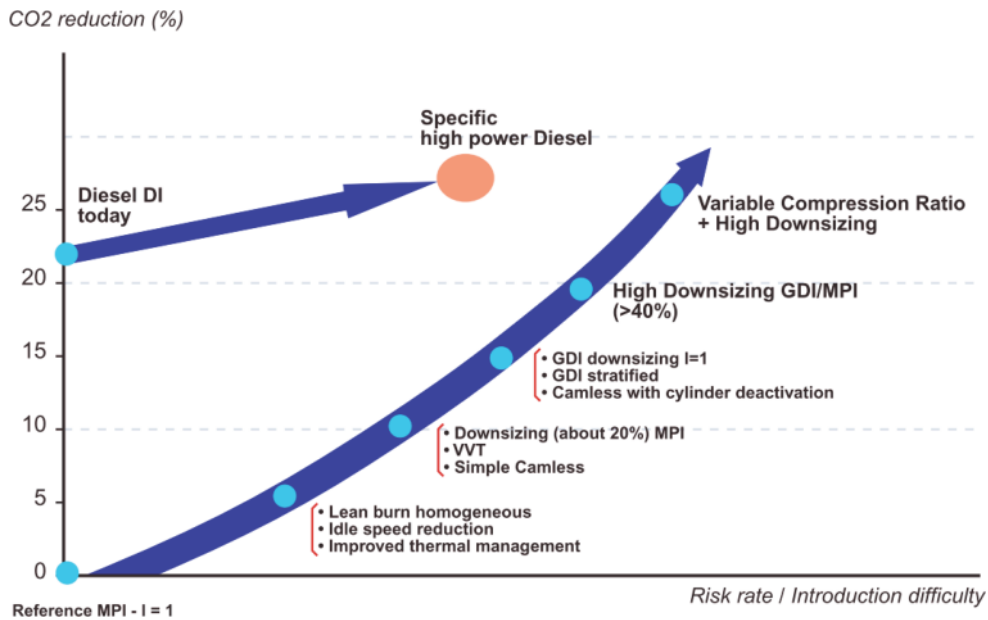

Figure 2.
 The foreseen decrease of CO₂ emissions, thanks to the use of VCR and VVA technologies [1].

higher boosting pressure. Reduced stroke volume can be also obtained, among others, by reducing the number of cylinders. It means the mechanical and thermal losses are reduced, as well cylinder charge exchange losses, the so-called “pumping” losses too. At the same, the overall efficiency of the engine increases. On the other hand, an increase in the boost pressure requires a reduction of geometric compression ratio to avoid adverse phenomena in the combustion process. Due to the direct relationship with the cycle efficiency, it is preferred to use as high compression ratio as possible. So, the compression ratio value must be a compromise between achieving the high thermal efficiency of the cycle and other restrictions, such as: knock limit, level of mechanical and/or thermal loads, maximum rate of pressure rising (engine run hardness), etc. However, these limitations are only in force at high engine loads, especially at high boosting. In conventional engines, the compression ratio is optimized and finally determined for these operating conditions. However, this is not a significant area of their usual operation. At low and moderate loads, the compression ratio could be much higher, giving increased operational efficiency of the vehicle. Therefore, the VCR technology enables a significant extension of the “downsizing” range, allowing further reduction of the displacement volume and the use of even higher boosting pressures. It is estimated that this method of adjusting the working parameters of the spark-ignition engine can result in a reduction in the fuel consumption by up to 30% without a significant increase of toxic exhaust compound emission [1].

Finally, the next area of using VCR technology is the possibility of effective implementation of advanced, low-temperature LTC combustion processes (low-temperature combustion). They are characterized by extremely low emission levels of toxic compounds as a result of high complementarity of the combustion phase, but conducted under conditions with reduced charge temperature. Especially, a lack of temperature gradients in the combustion chamber is the main cause of avoiding nitrogen oxides’ formation. There are, however, certain difficulties in obtaining low-temperature combustion stability under the high engine loads. Within this range of engine operation, a new VCR variable compression ratio technology exhibits a promising application potential, thanks to the high ability in moderating

the thermodynamic conditions in the combustion chamber, which determine the initiation and course of combustion process.

2. Technical methods for implementation of variable compression ratio technology in piston engines







Theoretically, there are several possible methods of using the variable compression ratio VCR technology in piston engines. Some of them were used in prototype engines and they undergo operational tests.

Table 1 schematically presents selected VCR layouts together with a brief analysis of their technical and operational features, including advantages or disadvantages in relation to the conventional construction of the engines. Noteworthy is the solution (f) of a complex lever-gear crank system, developed and applied by the French research group MCE-5 Development [2], as well as the SAAB SVC engine [3, 4], according the principle (a) and solution (c) implemented in the FEV Motorentechnik research engine [5].

There are many specific and unique constructions of VCR engines or even engine ideas and patents. **Table 1** collects the best-known approaches for VCR engine:

- a. articulated monohead—the SAAB completely functional engine SVC [3, 4],
- b. piston of variable deck height—different layouts presented by Daimler-Benz and Ford, as well [6],
- c. eccentrics on crankshaft bearings developed by FEV [5],
- d. multilink rod-crank mechanisms developed by Nissan [7],
- e. secondary moving piston or valve in cylinder head—different Ford and Volvo/Alvar proposals [6],
- f. gear-based crank mechanisms by MCE-5 [1, 2],
- g. precisely shifted cylinder block—cylinder head assembly—used in authors' own project [8, 9].

Each of above are presented and widely discussed by Shaik et al. [6]. The SAAB's SVC engine according to the solution (a) has been developed earlier by Larsen [3]. The compression ratio is variable from 8:1 to 14:1. Similarly to the shifted cylinder head method (g), it reveals good compression ratio control ability, but with slight change in piston kinematics. As a common drawback of both systems, a worse reliability and durability characteristic can be pointed. The solution (b) based on piston deck height variation uses a complicated special piston construction [6]. It also does not provide easy and precise control of compression ratio. Eccentric on main bearings (c) seems to be devoid of substantial disadvantages, but it makes the crankshaft block more complex. This solution is developed by FEV and used in their concept VCR car [5]. Nissan Motors developed a multilink rod-crank mechanism [6] according to the layout (d). It provides moderate compression ratio control ability at significant change in piston kinematics. Changing compression ratio using a small chamber with moving piston/valve (e) is relatively simple method to be applied in standard engines conversion into the VCR engines. As the drawback of this manner for changing compression ratio, the poor combustion chamber

Design layouts	(a)	(b)	(c)	(d)	(e)	(f)	(g)	
Technical and operational features	 [3, 4]	 [6]	 [5]	 [7]	 [6]	 [1, 2]	 [8, 9]	
Combustion chamber consistency	Neutral	Neutral	Neutral	Neutral	\\ \\ \\	Neutral	Neutral	
Crankshaft mechanism kinematic	≠	Neutral	≠	≠≠≠	Neutral	≠≠≠	Neutral	
Mechanical and friction losses	Neutral	\\	Neutral	\\ \\	Neutral	∕∕	Neutral	
Engine design integrity and dimensions	\\	\\	\\	\\	\\	\\	\\	
Impact of variability of compression ratio on cyl. capacity	Neutral	Neutral	Neutral	\\ \\	Neutral	Neutral	Neutral	
Accuracy of control and range of changes in compression ratio	↑ ↑	↓ ↓ ↓	↑ ↑	↑	↑	↑ ↑	↑ ↑ ↑	

∕—improvement, \\—deterioration, ↑—high mark, ↓—low mark, and ≠—distinctive mark.

Table 1. Technical methods of application VCR technology in piston engines and their technical and operational features.

integrity can be pointed [6]. The gear-based crank mechanism (f) is very advanced technique extensively developed by MCE-5 research group [1, 2]. It shows high precision in CR control and profitable changes in piston kinematics that avoids side forces acting on the piston.

Analyzing the possible solutions of VCR engines, both hypothetical constructions and actual prototype units, two general strategies for changing the value of the compression ratio during the engine run can be noticed.

1. The change and control of the compression ratio at the assumed level takes place by changing the position or geometry of the engine part, which consist of the cylinder head assembly. This method does not interfere with the moving parts of the crank-piston system, thus the friction losses and kinematics of the crank-piston system during engine operation remain unchanged or change in a very small extent comparing to a conventional engine.
2. The change of the compression ratio is a result of the intended changes in the geometry and/or kinematics of the crank-piston system due to special constructions of mechanisms allowing for the correction of the distance between the top plane of the piston and the bottom plane of the head. In this case the power of friction losses in the crank-piston system usually increases, although it is also possible to be reduced (e.g., solution (f)—**Table 1**). Sometimes variation of the compression ratio according to these concepts also causes an unfavorable change in the cylinder stroke volume (e.g., solution (d)—**Table 1**).

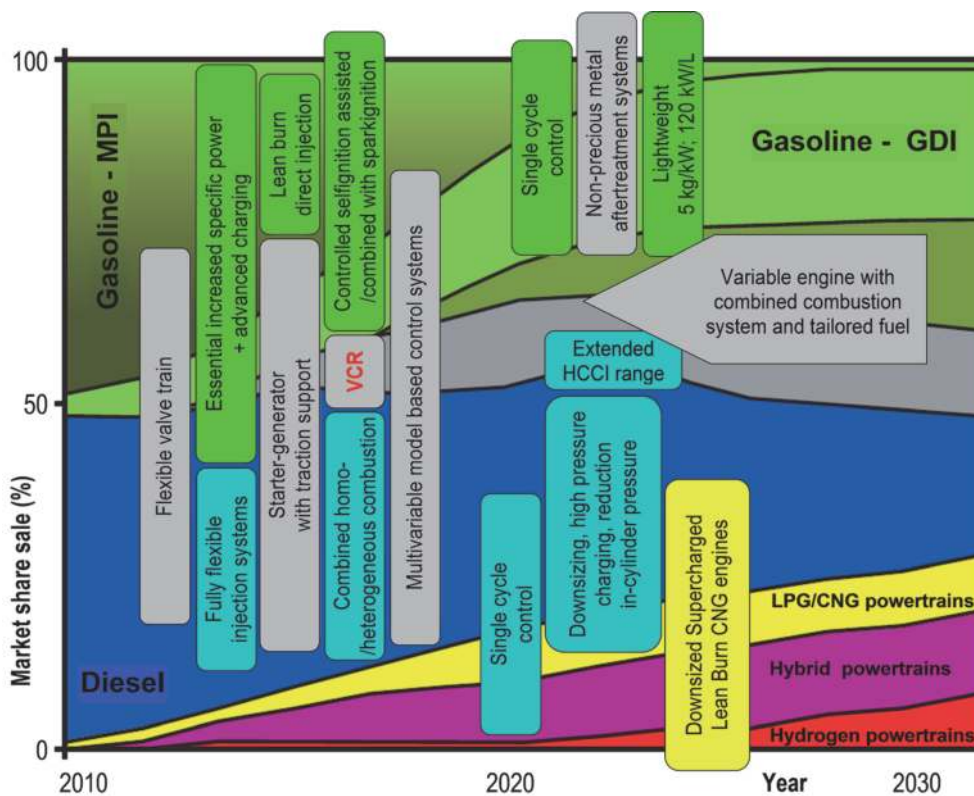

Figure 3. Forecasts for the development and share of selected advanced technologies in the combustion powerdrives of motor vehicles [10].

Despite the fact that the idea of variable-pressure VCR engines is associated with significant construction and technological complexity and many operational problems, it is estimated that it starts to become a technical standard for automotive piston engines in the near future (see **Figure 3**).

Therefore, it was accepted that development and building a prototype variable compression ratio engine, along with the acquired knowledge and experience, will allow for successive improvement of the design and, as a result, get a fully functional, unique research instrument that makes possible to perform a number of innovative scientific works.

3. Design assumptions for the test engine and selection of the base unit

On the basis of the analyses in the field of variable compression ratio technology, taking into account all advantages and disadvantages of the known technologies for of variable compression ratio engines and existing prototypes as well as own manufacturing capabilities, it was decided that the construction of the test engine will be carried out according to for the kinematic system shown on case (g) in **Table 1**, that is, consisting of controlled positioning and movement of the cylinder head assembly along the cylinder axis. This solution is characterized by relatively low implementation costs due to the possibility of conversion of a standard piston engine into the VCR one, simplicity of construction and control, while ensuring a relatively wide range of changes of compression ratio at a high accuracy in positioning. The engine will be based on a serial produced combustion engine. It was assumed that for the purposes of the assumed scope of experimental tests, it will be necessary to obtain a wide range of compression ratio variation covering typical values for both spark and diesel engines, that is, from around 9:1 up to 19:1. The test engine should be also liquid cooled to ensure good temperature stability during research.

A medium-speed, liquid-cooled 4-cylinder diesel engine manufactured by VEB IFA-Motorenwerk Nordhausen type 4 VD 14.5/12-1 SRW was selected for the

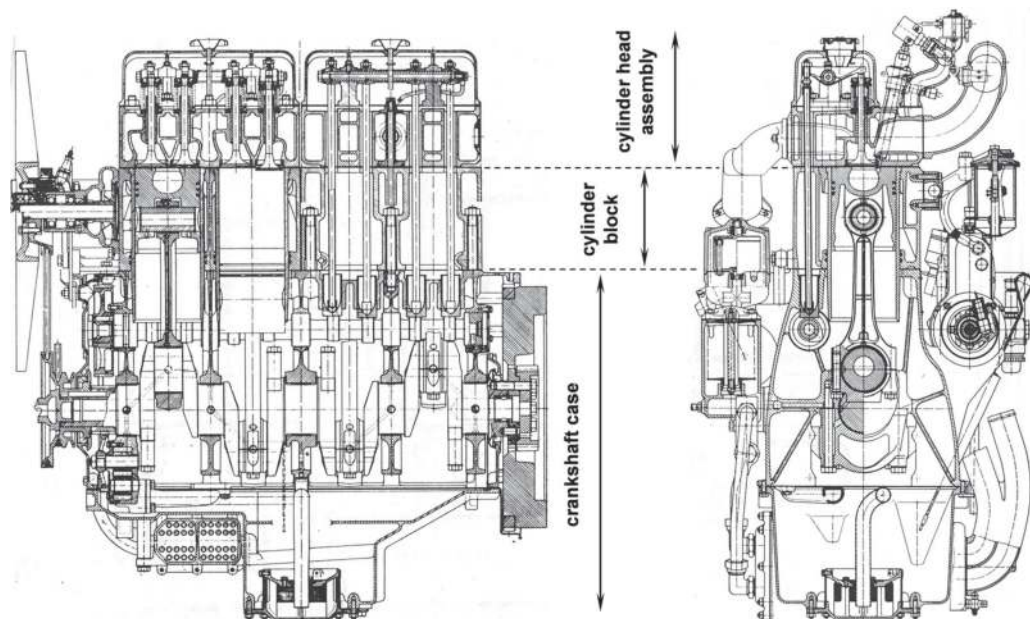

Figure 4. The main cross sections of the 4 VD 14.5/12-1 SRW engine as the basis for the own designed research unit in the VCR technology with the dividing planes of the engine body shown [11].

construction of the VCR engine. The unique structural feature of this engine, which decided on its selection, was the physically existing plane that divides the crankcase from the cylinder assembly (see **Figure 4**).

The basic parameters of the 4 VD engine are as follows: cylinder diameter—120 mm, piston stroke—145 mm, displacement—6560 ccm, original geometric compression ratio—18:1, valve drive system: OHV overhead valves with camshaft located in the crankshaft block, cam followers, sticks, valve arms mounted on the axle above the head. Detailed engine specifications are described in **Table 2**.

Geometric dimensions of the 4 VD 14.5/12-1 SRW engine allowed to determine how the compression ratio will change with the cylinder head assembly moving along the cylinder axis according to the relationship (Eq. (1)):

$$\varepsilon' = \frac{\frac{\varepsilon \cdot V_c}{\varepsilon - 1} + \pi \frac{D^2}{4} \cdot h}{\frac{V_c}{\varepsilon - 1} + \pi \frac{D^2}{4} \cdot h} : 1 \quad (1)$$

where ε' is compression ratio as a function of the cylinder head assembly shift, ε is original compression ratio, V_c is cylinder displacement, D is cylinder diameter, h is shift value of cylinder head assembly relative to the initial position.

Eq. (1), substituted with appropriate values, shows that the range of the cylinder head assembly tilting from initial position up to 10 mm travel gives the compression ratio changes from 19:1 to 9:1, according to the curve shown in the **Figure 5**. The

Producer	VEB IFA-Motorenwerk Nordhausen
Type	4-stroke, diesel
Number of cylinders	4
Ignition order	1-3-4-2
Cylinder layout	In-line
Piston stroke	145 mm
Cylinder diameter	120 mm
Displacement	6560 ccm
Compression ratio	18:1
Rated power	92 kW (125 KM)
Crankshaft speed at rated power	2300 rpm
Maximum torque	430 Nm
Crankshaft speed at max. torque	1350 rpm
Mean effective pressure	0.77 MPa
Specific fuel consumption for rated power	240 g/kW·h (175 g/KM·h)
Minimum specific fuel consumption	218 g/kW·h (160 g/KM·h)
Lubrication system	Closed circulation, pressurized
Fuel delivery	Direct injection (system MAN), single-hole sprayer, in-line section fuel pump with mechanical regulation of engine speed
Initial pressure of injector opening	17.5 MPa
Engine starter	Electric motor
Power and supply voltage of engine starter	3 kW, 24 V

Table 2. Original technical specification of the 4 VD 14.5/12-1 SRW engine [11].

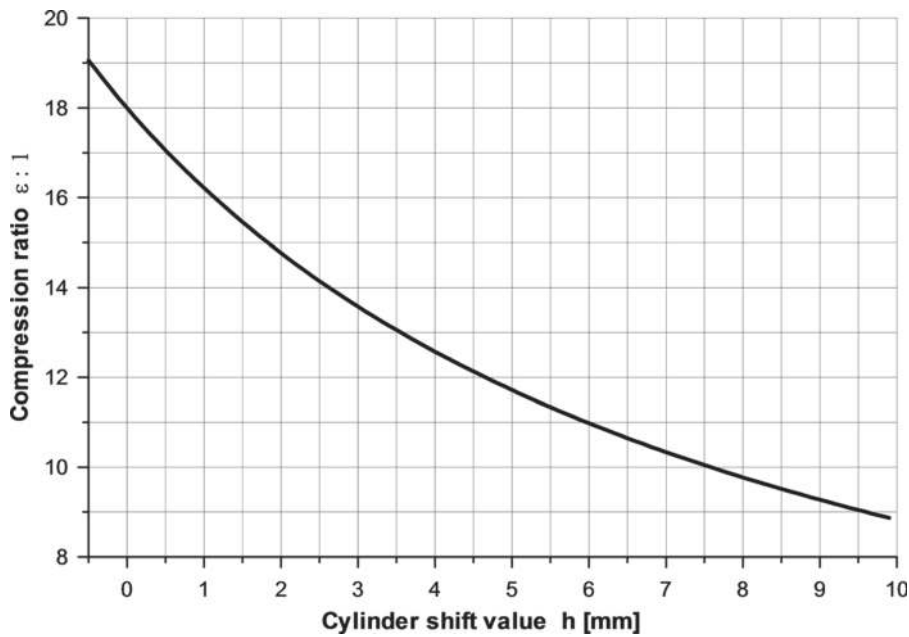

Figure 5.
 Compression ratio versus cylinder shift value for 4 VD 14.5/12-1 SRW engine.

range of these changes essentially coincides with the desired research scope of the engine. If necessary, it can be changed relatively easily by replacing the pistons with different volume of the combustion chamber [8, 9].

The adopted concept of changing the compression ratio requires the use of an accurate, precise cylinder head assembly shifting mechanism in relation to the crankshaft block. The requirement of this mechanism, in addition to the high accuracy of positioning and rapid change of the position of the cylinders, is to transfer gaseous forces generated by the combustion process in individual engine cylinders. The value of these forces can be determined from Eq. (2):

$$F_{\max} = p_{\max} \cdot \frac{\pi \cdot D^2}{4} \quad (2)$$

where F_{\max} is the maximum force acting on the shifting system due to the gas pressure in the cylinder, p_{\max} is maximum gas pressure in the cylinder, and D is cylinder diameter.

Assuming the maximum gas pressure in cylinders at 10 MPa, we obtain the force generated by a single cylinder at the level of 113 kN. Hence, the sliding mechanism must have adequate strength, but also rigidity, operational reliability, small dimensions and relatively high positioning resolution, especially in the range of high values of compression ratio.

The task of the newly designed mechanism for compression ratio changing is precise shifting the 4-cylinder “cylinder head” assembly in the range of 0–10 mm by means of synchronously rotating two eccentric shafts that are connected to the sliding elements by kind of yokes—connecting rods. The layout diagram and the source of the main mechanical loads are shown in **Figure 6**. The analysis of forces and torques shows that the eccentric shafts will be loaded with a twisting torque M_s of approx. 300 Nm each.

Figure 7 shows the location of eccentric shafts together with the shaft drive system. Both shafts have bearings on both ends and in the middle of their length. At the free ends of both shafts there are two geared right-angle power transmissions; their inputs are connected by a common drive shaft that is driven by a synchronous

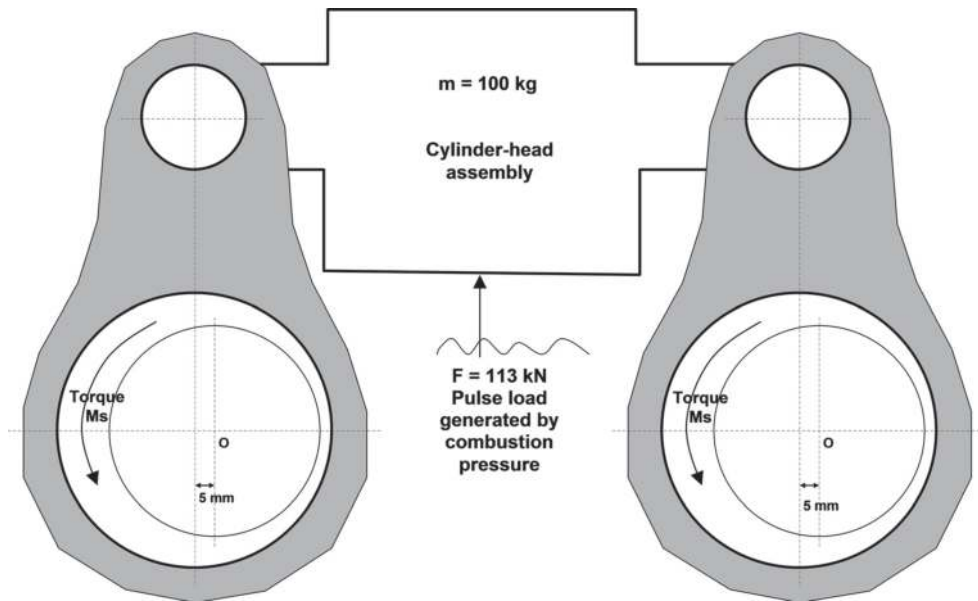

Figure 6.
Diagram of the yoke-eccentric cylinder sliding mechanism and the main sources of mechanical loads.

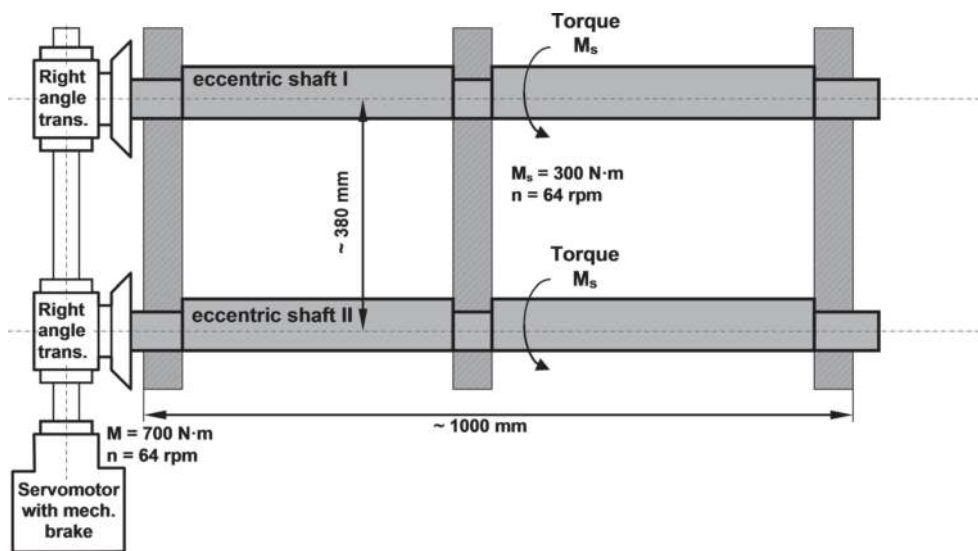

Figure 7.
Project of the location of eccentric shafts with the drive system diagram.

servomotor with a mechanical brake. The wheelbase of the shafts is approx. 380 mm, which directly fits to the design features of the test engine.

Analysis of loads shows that each of the bevel-gear transmissions has to transfer a maximum torque less than 300 Nm, while the main servomotor has to generate a double value of that torque, that is, at least 600 Nm.

Therefore, an appropriate selection of working elements has been made, taking into account the structural safety factors. The bevel gearboxes TRAMEC in the version RA 38AC 1:1 E B3 with the rated torque $M_a = 320 \text{ Nm}$ are used as the right-angle drives. As the servomotor a two-stage flat reducer, type Stöber SMS version F402AGN0470 EZ503U EL1, with an acceleration torque of 700 Nm, driven by the Stöber POSIDRIVE MDS5110A/L 11.0 kW $3 \times 400 \text{ V}$ inverter is used (**Figure 8**). All gear units are with reduced mid-gear lash to the value below 10 arc minutes.

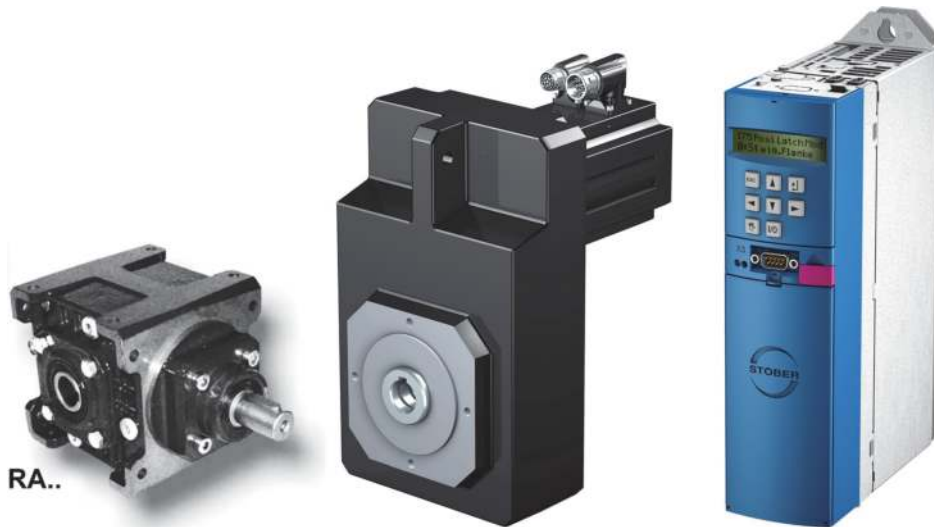

Figure 8.
Overall views of the RA type TRAMEC bevel gearbox, Stöber SMS servomotor, and Stöber POSIDRIVE MDS inverter.

Construction work began with the reverse engineering process on the research engine, that is, scanning the spatial engine body with the determination of characteristic points, surfaces, distances, clearances, etc., allowing the design and manufacture of other engine components and subassemblies. As previously mentioned, the characteristic feature of IFA 4 VD 14.5/12-1 SRW engine, which influenced the decision on its selection for adaptation works is the fact that the engine block is not permanently fixed to the cylinders. The division plane is shown in **Figure 9**. Its physical presence gave the opportunity to design and build an appropriate drive mechanism to realize the movement of the cylinders (together with the heads) in the vertical direction.

The basic elements of the cylinder sliding system are the servomotors chosen with catalogs, two bevel gears, drive couplings, and two eccentric shafts, connecting rods and a designed and made main support plate that keeps the

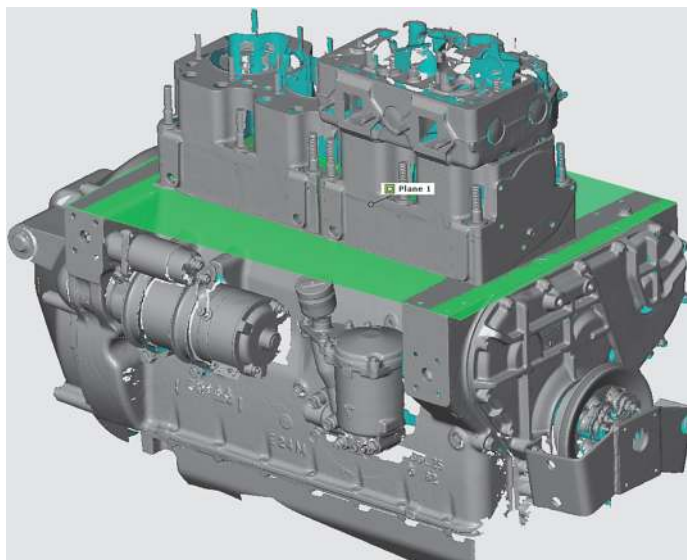

Figure 9.
3D scanning image of the IFA 4 VD engine as a base for performing necessary design and technological changes; the green plane is marked showing the division plane between the crankcase block and the cylinder blocks.

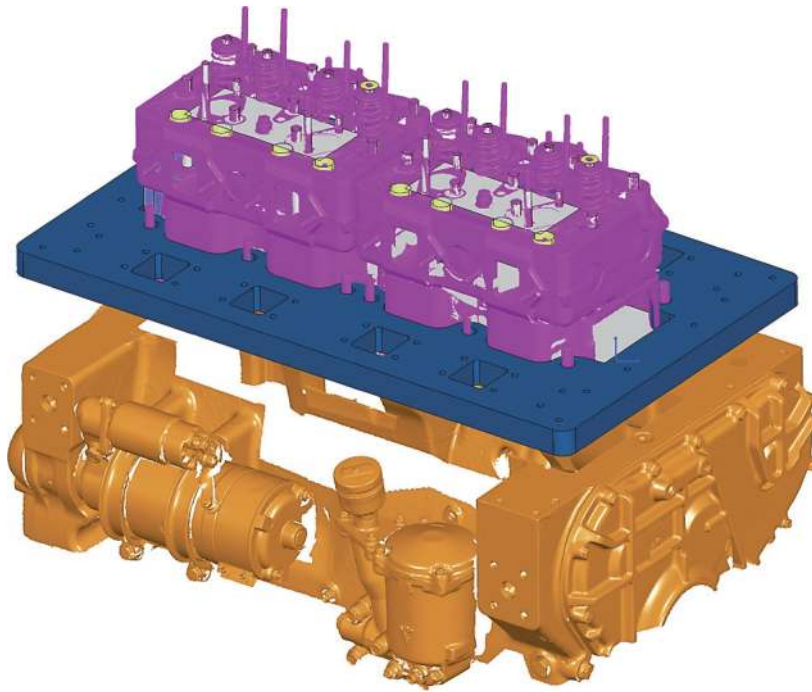

Figure 10.
Design of the cylinder support plate and its mounting on the screws fitted into the cylinder blocks.



Figure 11.
Connecting yokes mounted with the eccentric shafts.

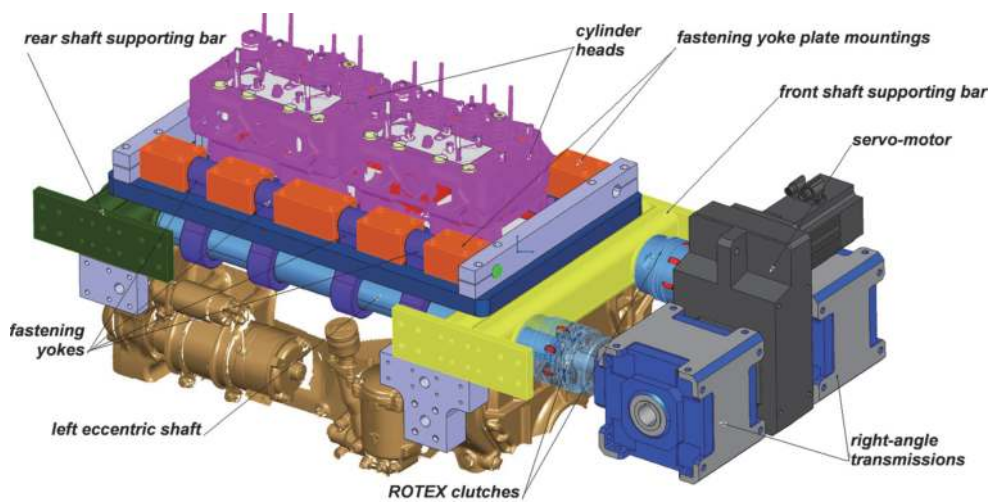

Figure 12.
View of the assembly of the cylinder blocks sliding system.

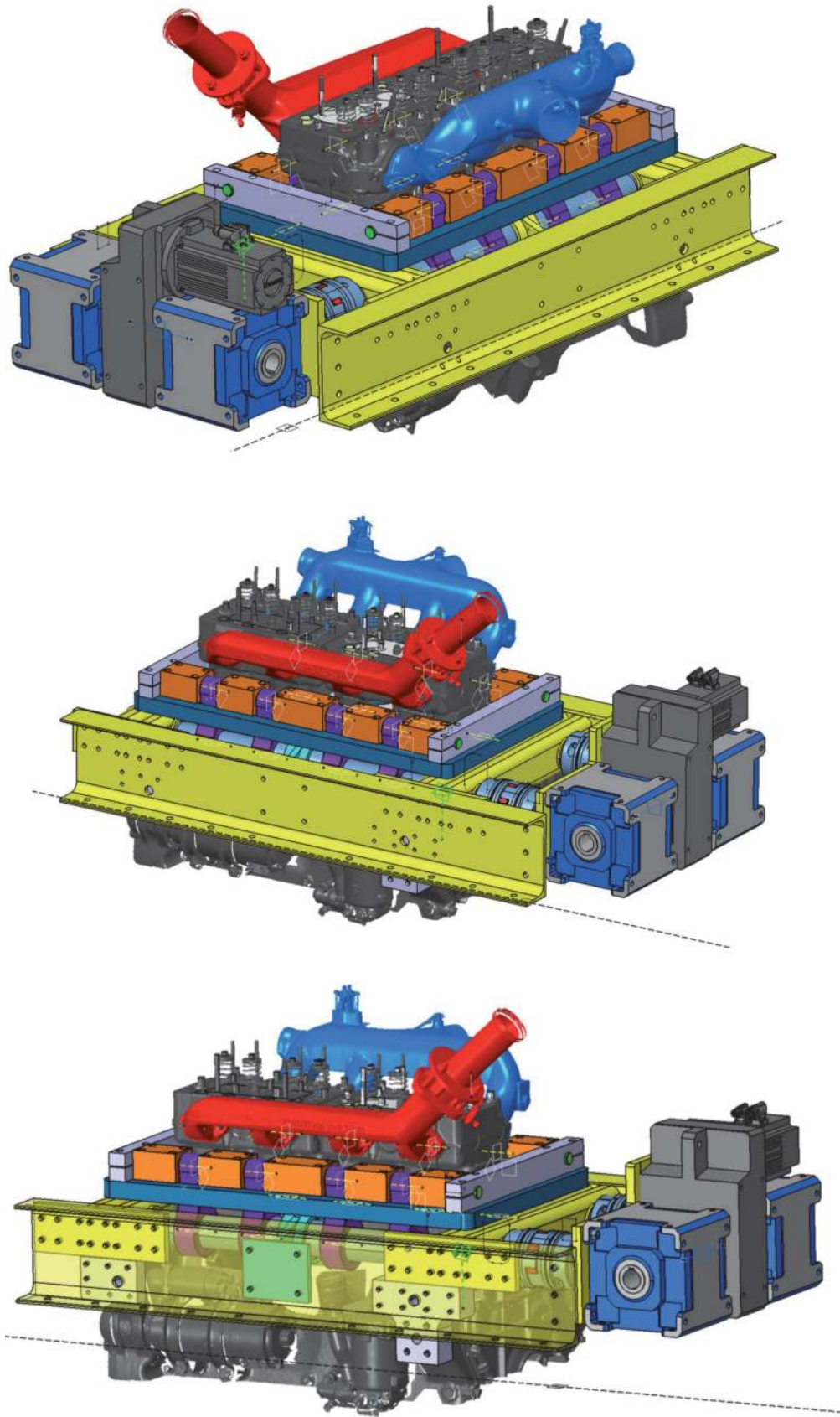

Figure 13.
An isometric view of the VCR engine with assembled with the cylinder sliding system and the drive mechanism of eccentric shafts.

cylinders. The main board (**Figure 10**, dark blue color) is seated and attached to the cylinder blocks using special threaded mounting bolts.

To allow the additional space for insertion of a flexible seal gasket between crankshaft block and cylinder blocks it was necessary to change the pistons with the larger height ones by at least 5 mm. Suitable pistons that meet the necessary



Figure 14.
View of the complete VCR engine during functional tests.

dimensions for the designed VCR engine were adopted from the HANOMAG D942 engines.

The next key stage in the VCR engine design process was the exact machining of eccentric shafts for the cylinder sliding system together with a set of eight connecting yokes. To ensure proper dimensional accuracy, technological work was carried out on CNC machine tools. **Figure 11** shows the connecting yokes fastened with the eccentric shafts.

The movement of the supporting plate together with the cylinders is enforced by an eccentric-crank mechanism driven by a complex servomechanism (**Figure 12**), that is, through two angle bevel gears and two eccentric shafts. The elements shown in orange make the assembly fixing the axle passing through the connecting rod holes. Eccentric shafts are mounted in sleeves welded to the transverse beams (green and yellow). The drive for eccentric shafts is transmitted via two ROTEX GS clutches. Any disorders and risk of misalignments in movement of the cylinder-cylinder head assembly is secured by set of sliding barrels. Sliding barrels are permanently fixed in the crankcase and fitted into the precise holes made in the cylinders body.

The entire design of the VCR engine, for a better illustration of its structure complexity, is presented in isometric views in **Figure 13**, while the finally completed research engine with variable compression ratio is presented in **Figure 14**.

4. Conclusion

Piston engine for many decades is a basic and commonly used source of mechanical drives in various types of machinery and technical equipment, including motor vehicles and other means of transportation. Despite the various controversial forecasts and views that have recently appeared, and not always are based on trusted and documented technical knowledge, the combustion engine will certainly remain an irreplaceable source of propulsion for many branches of transport and industry. One should keep in mind the intense scientific, technical, and technological progress that makes the final product even more and more technically perfect. Taking into account the current development trends that arisen from an experience of recent years, which are focused mainly on improving combustion processes, it can be noted that the presented technical development of VCR internal combustion engines gives a significant contribution in this process.

A great innovation and application potential is shown by the worked out original design, constructional and technological achievements covering a four-cylinder combustion engine with a variable compression ratio VCR feature. Attempts to develop such an original powerdrive unit, except for some major automotive industry efforts, were usually finished unsuccessfully. The developed design of the VCR engine opens up new research and development opportunities that were not available before. It concerns mainly to new directions of improvement of engine working processes and exploitation possibilities of internal combustion engines, that is, research on advanced, low-temperature combustion processes or research on the unification and flexible use of various fuels for transportation, including alternative fuels of different reactivities.

Acknowledgements

Authors wish to thank to the Ministry for Science and Higher Education in the Republic of Poland for their financial support of this work.

Author details

Paweł Woś*, Krzysztof Balawender, Mirosław Jakubowski, Artur Jaworski,
Paulina Szymczuk and Adam Ustrzycki
The Faculty of Mechanical Engineering and Aeronautics, Rzeszów University
of Technology, Rzeszów, Poland

*Address all correspondence to: pwos@prz.edu.pl

IntechOpen

© 2020 The Author(s). Licensee IntechOpen. This chapter is distributed under the terms of the Creative Commons Attribution License (<http://creativecommons.org/licenses/by/3.0>), which permits unrestricted use, distribution, and reproduction in any medium, provided the original work is properly cited. 

References

- [1] MCE-5 VCRI: Pushing back the fuel consumption reduction limits, MCE-5 Development 2010 [Internet]. Available from: www.vcri.eu [Accessed: 5 October 2018]
- [2] Rabhi V, Beroff J, Dionnet F. Study of a Gear-Based Variable Compression Ratio Engine. SAE Paper No. 2004-01-2931. Warrendale PA, USA: SAE International; 2004
- [3] Larsen GJ. Research Engine for Evaluating the Effects of Variable Compression Ratio (VCR) and/or Variable Valve Timing (VVT). SAE Paper No. 910053. Warrendale PA, USA: SAE International; 1991
- [4] SVC Variable Compression Engine, Linköping University, Sweden 2014 [Internet]. Available from: www.vehicular.isy.liu.se [Accessed: 5 October 2018]
- [5] Habermann K. Demonstration Vehicle with Continuously Variable Compression Ratio (VCR). FEV Magazine "Spectrum", Issue 22, 2003 [Internet]. Available from: <http://www.fev.com> [Accessed: 5 October 2018]
- [6] Shaik A, Shenbaga Vinayaga Moorthi N, Rudramoorthy R. Variable compression ratio engine: A future power plant for automobiles—An overview. Proceedings of the Institution of Mechanical Engineers (IMEchE); Part D: Journal of Automobile Engineering. 2007;221(D9):1159-1168
- [7] Moteki K, Aoyama S, Ushijima K, Hiyoshi R, Takemura S, Fujimoto H, et al. A study of a variable compression ratio system with a multi-link mechanism. SAE Paper No. 2003-01-0921. Warrendale PA, USA: SAE International; 2003
- [8] Woś P, Balawender K, Jakubowski M, Kuszewski H, Lejda K, Ustrzycki A. Design of Affordable Multi-Cylinder Variable Compression Ratio (VCR) Engine for Advanced Combustion Research Purposes. SAE Paper No. 2012-01-0414. Warrendale PA, USA: SAE International; 2012
- [9] Woś P, Jakubowski M. Variable Compression Ratio Engine. Patent No. 217826. Warsaw: The Patent Office of the Republic of Poland; 29 August 2014
- [10] EUCAR R&D for Europe, The European Council for Automotive R&D Conference [Internet]. 2006. Available from: www.eucar.be [Accessed: 5 October 2018]
- [11] VEB IFA-Automobilwerke Ludwigsfelde (ed.), Service Manual for LKW IFA W50. VEB Fachbuchverlag, Leipzig 1972 (in German)