

## Chapter

# Stress-Strain Relationship: Postulated Concept to Understand Genetic Mechanism Associated with a Seismic Event

*Umesh Prasad Verma, Madhurendra Narain Sinha,  
Pushan Kumar Dutta and Subhra Mullick*

## Abstract

In this study, we propose the design methodology for monitoring the earthquake and for detecting and tracking micro-seismic changes in the earthquake prediction system. The alert device includes these sensors will be drastically different from current early warnings using the dozens of seismometers network across seismically active regions for measurement of small acceleration signals directly and, as the first, low-noise stage of the instruments measuring low-noise velocity signals. Strain develops over considerable time in the overlying stratum at right angle to the applied shearing (max) stress, obeying the internal friction of the stratum, available seismic energy and law of stress-strain relationship. Using estimated energy (seismic), stress accumulation, the addition or subtraction in the strain rate due to stress developed can be analyzed for a seismic event. This concept may lead to better understanding of stress generation; build up, transfer and final drop. Then we propose a methodology to identify type of data can be used for the spectral analysis in earthquake seismology and what type of instrument can be used for the spectral analysis in for data acquisition.

**Keywords:** Strain rate, Field velocity, Axis rotation, Stress-Strain relationship, Seismicity Stress generation

## 1. Introduction

Recent advances in seismic data acquisition techniques and equipment motivated the geo-scientific community in comprehending the complicated structure and dynamics of Earth, which has shown that plate tectonics can explain properly oceanic plate behavior having few large and rigid plates and but not fully well continental plates with models requiring quite a lot of small blocks due to in-situ material heterogeneity prevalent in deforming regions, such as rifts, spreading zones; collisional and subduction system including mountain belts. In this context, prediction of earthquake has become a very challenging task of scientists as it is not possible with the current state of knowledge of science because of involvement of complex physics of earthquake in its generating processes. It is the fact that we are

trying to predict the unpredictable, which can be successfully achieved once the diagnostic parameters (precursors) responsible for genesis of the earthquake are known to us, which in turn suggests that the earthquake generating mechanisms are not completely known and well understood till today. In this proposed study, we review and revalidate the research aimed at unambiguously defined algorithms for seismogenesis that is central to the puzzle of geo-scientific community for mitigating the damage to floras and fauna for the benefit of entire mankind. The research conducted in this study deals with the integration of earthquake precursory analysis based on the integration of three methodologies, involving the phenomenological analysis of geo-scientific observations; universal models for the scientific validation of complex system design in statistical physics; and Earth-specific models of seismo-tectonic fault network observation. It is, therefore the study of earthquake, has become a subject of integrated multi-disciplinary geo-scientific research with aim of estimating a set of reliable diagnostic earthquake generating precursors so that prediction of the earthquake can be feasible with better degree of reliability.

This thesis is aimed at extending the scope of better understanding of earthquake generating mechanisms and its complexity in diverse geotectonic settings related to different seismogenic fault triggering systems (e.g., San Andreas Fault; East Japan fault; Himalayan Faults) for development of a holistic earthquake warning System for understanding earthquake generating processes in different tectonic environ, which can help us in adopting measures for mitigating earthquake hazards. It has been established that junctions of thrust faults and transverse lineaments near plate boundary are plausible vulnerable geotectonic settings for damaging earthquakes attributed to the rupture of the rock which occur in earthquake triggering zones following the accumulation of strain in the lithosphere. The complexity of the lithosphere shows that a multitude of mechanisms that affect the earthquake study are found to have certain space–time constraints. The motivation for defining a futuristic prediction scenario where rupture initiation and triggering models with various discontinuities is highly probable as a result of quasi-dynamic instability due to expansion of strain release areas and accumulation of strain in the fault patch has been critically examined in our study using nucleation models as a part of the design to define quasi-static nucleation models to explore the thrust fault locking zones in different earthquake prone regions. In order to enrich our understanding of the internal processes and deformation within the triggering zones that culminate into isolated fault segments with stress release and strain accumulation, we define certain interaction models which carry significant information about a short term precursory evaluation for the earthquake phenomena. The basic limitation of long term forecasting models and self organized criticality mechanism lies in its inability to define realistic geo-models able to explain the intricate forces involved in rupture based fault slippages on the nearby faults measured that may increase the overall stress on the linked fault in a short period of time. The earthquake genesis models can be defined mainly during short-term swarm events that cluster predominantly around the inside corner of ridge-transform intersections with events occurring on both the strike-slip and normal faults within the system. Precise earthquake locations along mid-ocean ridges, transform faults, and within hydrothermal systems can illuminate regions of active seismic deformation, and help us better understand the mechanics and kinematics of these plate boundaries. Earthquake prediction technique involves identifying the upper limit of strain for nucleation periods which is proportional to the magnitude of the mainshock. The nucleation patch is detectable everywhere locally in the earthquake causative fault and constrained the pre-rupture nucleation slip for destabilization of the stress-strength field due to realistic tectonic loading, spontaneous nucleation of the frictional instabilities and visco-elastic relaxation of the lithosphere. The modeled

seismicity shows that nucleation mechanism leads to the non-reversible expansions of rocks and spreading of the ocean floor in the neighborhood of the rupture or along the weakest rocks during inter-plate earthquake cycle. Our study starts from defining the problem of earthquake forecasting in the context of quasi-static dynamical models for earthquake nucleation initiation and subsequent arrest in the fault patch that is incorporated based on the time- and stress-dependencies of the nucleation process namely pre-slip models, colliding clusters or coalescence models, dilatancy models, characteristic slip or fixed time recurrence models and spatio-temporal clustering models where recurrent slip occurs in time with aftershocks, foreshocks, and pairing of main shocks. The present study proves that only way we can define earthquake forecast is through analysis of the source of earthquakes through interdisciplinary approaches of seismo-tectonic studies by observing strain accumulation and investigation of the physical change and temporal change of the rock properties in the earthquake source region. The variations of the stress field precede the main shock by days up to months through a sequence of simple accelerating nucleation process, and clearly inter-event triggering and a pre-existing near-critical stress field, operating over much longer correlation length scales in the incipient region called triggering basin which has been identified using spatial ant colony optimization models. Evolutionary robust computational algorithms are found to help in the recognition and understanding of the triggering mechanisms for localization of the focal area in the foreland basin in a near-critical state condition.

In the scheme for data analysis and earthquake genesis model section, we have developed and tested methods analyzing low signal to noise non-stationary data with quasi-periodic components characteristic of earthquakes. The dependence of seismicity on the general properties of the fault network can help in the analysis of local fracture stability by analyzing common characteristics of the seismicity behavior, identification of the missing attribute for seismicity and through identification of the unobserved models of seismicity which are characterized in the time series data. We focused on different data based techniques involving continuous time signals for earthquake analysis such as catalogs, acceleration-time series data, radon count analysis, image-processing techniques that can be used in validating and testing earthquake models. In this study, several case studies derived from catalogs for earthquakes occurring in the Himalayan Basin from about six decades of different researchers are taken up for analyzing the seismic trend using least square regression and weighted least-square regression. Local search models can be applied for analyzing rupturing and interaction for earthquake nucleation and triggering mechanisms can be quantified and their correlation can be studied with feed-forward neural network with backward projection for studying spatio-temporal seismicity clusters in the Himalayan Basin based on the physical processes governing dynamic rupture nucleation, growth, and arrest. The heterogeneity of the strength distribution for a recurrent time –asperity model has been found to depend on the critical strain as crack heads nucleate in meta stable condition and numbers increases rapidly. In this regime dominated by nucleation and growth of individual fractures, the population law exhibits power length distributions as the nucleation rate decreases as more regions become part of the stress affected regions resulting in the decrease in the number of fractures. This has been proved in the Himalayas subduction region could be explained by a coupling process between the observed physical parameters and the earthquake preparation processes. We have also used a Kalman particle filter and an improved Periodogram analysis in the design of a novel algorithm to find the statistical estimators for extracting the cumulative slip from the earthquake acceleration data for the 2011 Sikkim Earthquake Data. In this approach, an attempt is made to apply different algorithms to undertake detailed study on thrust-fault behaviour for better understanding of

earthquake generating processes. A new algorithm is proposed to estimate rupture directivity using peak ground acceleration data instead of strong motion data, and we found that peak ground acceleration parameter with rupture directivity is an important input with immense potential for earthquake forecast and warning system.

In this study various conceptual models are analyzed among which a quasi-static nucleation model is used for validating the seismogenesis of earthquakes occurred in different tectonic settings. The fragmentation of structures and the rotation of the blocks is found to affect the driving force analyzed through non-linear correlation models which impart information based on the temporal-spatial evolution processes of fault stress in the stages of stress deviating from linearity and meta instability in two or three dimensions as colliding cascade, pre-slip, characteristic earthquake models, dilatancy model and spatio-temporal clustering of earthquake models. The dilatancy model has shown that fault edges can stay locked over an infinite depth over the entire seismic cycle, possibly by volumetric deformation in the seismogenic zone at different stages of the seismic cycle. The connection between seismicity and geodynamic models has been found rejuvenated using Radon emission in the San Andreas Fault from 1978 to 1981 and the Bayesian likelihood for a drastic change in the strength of an array and reset the elastic stresses by external forces (earthquake) occurs when certain changes in the structure of the array as the compressive and tensile strength of the rock array. Based on subjective analysis we analyze how this model enable or inhibit rupture to overcome regions of faults unfavorable to rupture.

In this piece of research, it is found that there is a need to reliably describe the complexity of the source of a seismic event by evaluating parameters pertaining to changes in stress, strain and rheology of seismic deformation processes apply discrete-time Hidden Markov Model in order to reveal the stress field underlying the earthquake generation. For the Tohoku earthquake, we have studied fault segmentation through studying fault inter-segment areas usually associated with local slip and fractal clustering through Graph cut based image transformation carried out for pre and post earthquake image analysis applied for the 2011 Tohoku earthquake for satellite image analysis. In the later meta-instability stages, it has been found that strain release areas expand by linking with each other indicating the instability leading to an impending earthquake event based on the dynamic variation associated with meta-instability stage. The increase of such areas is a practical indicator of the expansion, accelerated expansion and linkage of nucleation models that give us a tested approach for earthquake forecasting called System of geodynamic monitoring in localness, radon behavior models and rotation of the earth to observe the difference in the rate of acceleration or de-acceleration of the tectonic plate prior to a mega-thrust earthquake using earth rotation data for the 2011 Tohoku earthquake for different time events to relate seismicity with the Earth spin changes. The variations of the stress field precede the main shock by days up to months trigger the role of faults in regional deformation in the time of around 150 days. The recognition and understanding of the triggering mechanisms can help to the localization of the focal area in the foreland basin. Triggering basins serve as harbingers of large earthquake where stress-strain interactions have been analyzed by the quasi-static mechanics of seismic precursory stress-strain propagation in the crustal lithosphere that can make time-dependant rupture analysis and define the likelihood of the occurrence of the earthquake in the future [1]. The first stage of the rock fracture begins when the stress curve deviates from linearity as differential strain variations occur at every portions of the fault due to change of rock stiffness equivalent to the tensibility co-efficient resulting in isolated areas of stress release and strain accumulation. In the second stage, strain release areas associated with

quasi-static instability undergo a state of locking that initiates the early meta-instability for non causal behavior of stress variability that initiates instable slip of fault as an independent activity for dissipation in nucleation of each fault part into a steady state evolution for stress transfer [2]. When the unstable slip function associates itself to the attractor states for the optimal state sequences, the fault enters the meta instability stage of the rock matrix when isolated strain release areas of the fault increase and stable expansion proceeds as a distribution of the residual strain and is augmented by the sub-surface heterogeneous environment. All these observations suggest that understanding of the earthquake generating processes requires multi-disciplinary approach which can be analyzed based on the rock properties using a reduced roughest approach for rock characterization. When slips occur between the crust and the tectonic plate, the stored elastic energies are released in “bursts” which can be detected as earthquakes. As the stresses become more intense, the elastic strain energy stored in a portion of the crust (block), moving with the plate relative to a “stationary” [3] neighboring portion of the crust, can vary only due to the random strength of the solid–solid friction between the crust and the plate. This may suggest clustering and specifically localization around planes, migration, spatio-temporal gradients of seismic parameters within a limited range. As the steady expansion is associated with quasi-dynamic instability, interaction between the areas expands with fault linking as earthquakes are generated. The process of meta-stability shows that weak and strong segments associated with fault strain release and strain accumulation is found to occur successively as relatively independent and quasi-static triggering of the rock. The location and timing can be identified for linking the segment and conducting a location error based analysis for optimal allocation of wireless sensor networks nodes which measure the received signal strength for a certain parameter that is highly useful in designing for the earthquake early warning system (EEWS) in future. Our comprehensive study made us understand that the reliability of the EEWS depends up on the degree of integration among various methodologies and models, which have strong bearing on determination of earthquake location, depth, size and the nature and extent of fault rupturing.

Stress generation effect and its mechanism causing seismic forces<sup>1</sup> [4, 5] related with endogenous and exogenesis sources both. Correlation of data on strain rate for past events of Tibet, Anatolia, 1994, Sikkim, 2011 and Turkey, 2011 supports the concept. Astrophysical like (celestial objects viz.; Sun, Moon, mars. and Jupiter) influence on gravitational pull on the Earth which ultimately is responsible for the stress building forces at the interface of Lr-up mantle<sup>2</sup> [5, 6] affecting seismicity at an area. The nucleation patch is detectable everywhere locally in the earthquake causative fault and constrained the pre-rupture nucleation slip for destabilization of the stress-strength field due to realistic tectonic loading spontaneous nucleation of the frictional instabilities and visco-elastic relaxation of the lithosphere. It is necessary to identify the duration for earthquake rupture initiation for the dynamic stress drop and episodic changes involved for the path of stress relaxation to the most stable condition. The strain rate measurement by GSRM<sup>3</sup> [5, 9], and GPS data

---

<sup>1</sup> Stress generating forces are consequences of either exogenetic or Endogenetic effect as astrocelestial neration is initiaobjects’ dynamics and status of grvatatonal forces.

<sup>2</sup> At the interface of Lr Up mantele interface stress generation is initiated due to reactive force of gravtational pull interacting in between sun –moon and earth system.

<sup>3</sup> GSRM stands for the Global strain rate measurement data which in elaborate manner has been produced by zhao jeng and E Hot of Stony Brook universitymore in formationin reference ctation no [5, 7, 8] can be available.

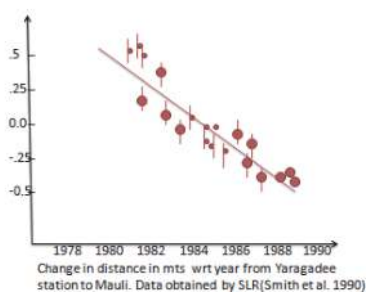
system<sup>3</sup> [1, 2, 7, 10–12] have cited their work on the strain rate measurement on the Asian region of Tibet and Anatolian plateau. Pattern of strain rate expansion and contraction and calculation of axis rotation and field velocity put interesting observations to be investigated in their works. Contraction alludes for overlooking the impending seismicity and expansion for positive occurrence. Through the equation below

$$\epsilon_{xyz} = \frac{1}{\epsilon(\sigma_3 - \sigma_3)} \propto C\Delta T \quad (1)$$

$\epsilon_{xyz}$  is utilized for measuring the 3D strain development due to applied stress on the reservoir rock underlying the stratum. On real time analysis with the available data on strain rate and field velocity measurement: Kreemer et al. [13] and Marrett and Allmendinger [14] could not establish the concrete relationship between stress and strain behavior to follow up for an impending event. In the present paper mission is to encounter the shortcomings. The latest model version of May 2004 (i.e., GSRM version 1.2) includes 5170 velocities for 4214 sites worldwide [11]. The model consists of 25 rigid spherical plates and ~25,000 0.6° by 0.5° deformable grid areas within the diffuse plate boundary zones (e.g., western North America, central Asia, Observations on the available data set for tensor moment of earthquake events since 1976 to recent period on Asian region Viz Anatolia, and Tibetan plateau<sup>4</sup> [8, 16] shows haplessness to foretell the forthcoming events arrival due Strain rate measurements, over an area by GSRM<sup>4</sup> [8] and GPS data sytems<sup>4</sup> [8, 15] help in establishing the nature and pattern of the medium and strain velocity. Expansion and contraction rate details, at times, impede detection of exact magnitude, direction of vectors and axis rotation. Minute measurement of direction and magnitude of strain rate, using the proposed concept, helps in better understanding of seismicity.

The proposed work is used to highlight the novel concepts developed through investigation to explain the appropriate mechanism and cause of seismicity at an area on the basis of strain velocity vectors (in expansion and contraction term) The findings of facts are in support by the ISAR Infermetry; Price and Sandwell [17] for

Stress strain relationship

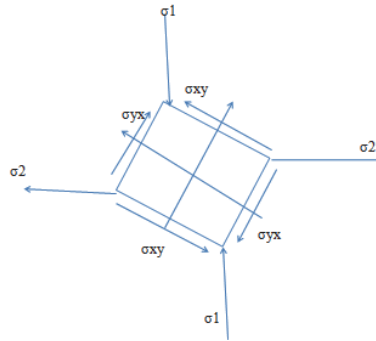


**Figure 1.**

*Principle and mechanism: Principal stress on the rock volume considered cause the strain following law and rules of rock mechanics<sup>6</sup> [7, 9] first, the Collaboratory study of earthquake predictability (CSEP; Jordan et al. [21]) is accepting global agreement in the seismology.*

<sup>4</sup> Global positioning data reveals besides the GSRM data for strain rate vectors size and direction for Tibetan and anatolia plateau which are insufficient to caculate itself stress generation on the site. In Ref. [8, 15] comprehensive information are laid for pattern and medium of strain vectors progress.

Mechanism of stress generation



**Figure 2.**  
 An attempt to explain the nature of strain produced to impending principal (deviatoric) stresses in the horizontal plane over the stratum rock unit: Courtesy: Fundamentals of [19].

event of Landers, California Earthquake (7.3Mw) on June 28, 1992.<sup>5</sup> [18–20] (Figures 1 and 2).

Expression from [19]<sup>6</sup> [18], we have equation below.

$$\epsilon_1 = \frac{1 + \nu}{\epsilon} \{ \sigma_1(1 - \nu)\nu\sigma_2 \} \quad (2)$$

Which was put in by Smith et al. [22]<sup>6</sup> to be cited from Refs. [9, 23].

Symbols has meaning like:  $\epsilon$  = strain;  $\nu$  = poisson ratio;  $\sigma_1, \sigma_2$  are (deviatoric) principal (deviatoric) stresses;  $\epsilon$  = coefficient of elasticity of the materials interacted by stress.

Again, strain the y axis direction<sup>7</sup> [4, 7, 10].

$$\epsilon_2 = - \frac{1 + \nu}{\epsilon} \{ \sigma_2(1 - \nu)\nu\sigma_1 \} \quad (3)$$

With the thermal stress effect on the stratum rock thermally unconstrained we get change in temp. That can lead to large change in pressure or stress as in the equation<sup>8</sup> [4, 7, 10].

<sup>5</sup> ISAR Interferometry; Price and Sandwell [17] for event of Landers, California Earthquake (7.3 Mw) on June 28, 1992)<sup>9</sup> [18, 19]. Inverse Synthetic aperture Radar system on real time sampling is available by Phillippe Lacomme, Eric Norment in Air and spaceborn Radar system, 2001.: Science Direct topic, [http:// Science Direct .com landers california earthquake \(7.3.Mw\) June, 28 in1992](http://Science Direct .com landers california earthquake (7.3.Mw) June, 28 in1992) was worked out with the ISAR interferometry data analysis by Price and Sandwell [17]. It includes principles of Rock Mechanics and in seismology. These rules use mathematical modeling and equations of stress strain relationship in context with viscosity and linear expansion in the rock body due to thermal stress and produced strain symptomised by strain field vectors. Discussed in the reference [7, 9] as predictability solution for any seismic event by Jordan et al. (2007)

<sup>6</sup> Expression from the rock mechanics [18, 19] we have, in the Eq. (2) of the text stated. Mathematics and relationship in between strain rate  $\epsilon_1$  elasticity  $\epsilon$  of rock interacting stress  $\sigma_1$  and viscosity  $\nu$  with thermal strain  $\gamma$  are revealing direction and amount of strain produced over the rock surface. These are viewable in form of vectors progression over the GSRM map by E Holt.

<sup>7</sup> Smith et al. [22] have implied the use of Eq. (2) in his literature Refs. [9, 23].

<sup>8</sup> Similarly as in Eq. (2) stress  $\sigma_2$  interacts as intermediate principal stress along horizontal direction yielding strain at right angle to the imposed direction as  $\epsilon_2$  in Eq. (3), whose better explanation is available in texts of Refs. [4, 7, 10].

$$\varepsilon_1 = \frac{1}{\varepsilon} \{\sigma_1 - \nu\sigma_2\} \alpha x T \quad (4)$$

From the theory of linear elasticity, Muskhelishvili [3].<sup>9</sup> Further linear elasticity is modified as<sup>10</sup> [9].

$$\varepsilon_1 = \varepsilon_2 = \varepsilon_3 = -\frac{1}{\varepsilon} \alpha \nu \Delta T \quad (5)$$

And<sup>10</sup> [9],

$$\varepsilon_1 = \frac{1}{\varepsilon_1} (\sigma_1 - \nu\sigma_2 - \nu\sigma_3) - \alpha \Delta T \quad (6)$$

$$\varepsilon_2 = \frac{1}{\varepsilon_2} (\sigma_2 - \nu\sigma_3 - \nu\sigma_1) - \alpha \Delta T \quad (7)$$

$$\varepsilon_3 = \frac{1}{\varepsilon_3} (\sigma_3 - \nu\sigma_2 - \nu\sigma_1) - \alpha \Delta T \quad (8)$$

These Eqs. (7)<sup>11</sup> [9] and (8)<sup>12</sup> [9] will give associated effect of temperature and thermal expansion over the Rock Stratum.

In vertical direction for half space,  $\sigma_3$  is 0 and<sup>12</sup> [9],

$$\sigma_1 = \frac{\varepsilon \alpha \Delta T}{1 - \nu} \sigma_2 \quad (9)$$

From the Text of Rock Mechanics substituting these values into (4) we obtain

$$T = \Delta T = \exp \frac{y\sqrt{\omega}}{2k} + \cos \left( \omega t - y \frac{\sqrt{\omega}}{2k} \right) \quad (10)$$

Where  $y$  = surface length,  $k$  = thermal diffusibility in  $m^2/s$  K,  $c$  = specific heat of the rock of stratum,  $\alpha$  = linear coefficient of expansion.  $\sigma_{\max} = \frac{\varepsilon \alpha \Delta T}{1 - \nu}$  With thermal and elastic stress effect on rock stratum<sup>13</sup> [9, 17].

<sup>9</sup> Eq. (3) states the Absolute value of strain amount as vector size on map in X direction as consequent interaction of Principal stress in x direction minus intermediate stress  $\sigma_2$  in y axis multiplied by poisson ratio and minus joint effect of temperature, thermal expansion and poisson ratio of the rock under stress.

<sup>10</sup> From the theory of linear elasticity, by Muskhelishvili (1963) which is to be cited from Ref. [9] It. He is briefed as in the referenced author strain produced over a rock in all the three x,y and z direction are equal to one third of linear expansion  $\times$  poisson ratio  $\times$  thermal gradient as in following Eq. (5) Further linear elasticity is modified in Ref. [9].

<sup>11</sup> In the Eq. (6) of manuscript value of strain depends on the principal grwates stress subtracted from joint effect of intermediate and least stress in the space due to convestive thermal activity which has been dealt in Ref. [9].

<sup>12</sup> Eqs. (7) and (8) of text is incorporating the strain value in y and z direction respectively as per interacting stress secondary and r (intermediate 0 and least acting at perpendicular to the strain production direction and is cited from the work from Ref. [9].

<sup>13</sup> Deal with the stress calculation steps in the Eqs. (10) and (11) involving frequency and phase of wave (of stress) due to thermal difusibility and thermal expansion of rock, its elasticity and poisson ratio whose relationship is output from Rock Mechanics cited in Refs. [9, 17].



$$\sigma_1 = \sigma_2 - \frac{h}{1 - \nu} (\rho g \nu + \epsilon \alpha \beta) \quad (11)$$

Here  $\beta$  is thermal gradient; With thermal and elastic stress effect on rock stratum: Pressure at depth  $h$  is<sup>13</sup> [4, 7–10, 16–18, 23].

$$P = P = P = \frac{1}{3}(\sigma_1 + \sigma_2 + \sigma_3) = \frac{1}{3} \frac{1 + \nu}{1 - \nu} \left( h \rho g + \frac{2}{3(1 - \nu)} \epsilon \alpha \beta \right) \quad (12)$$

Thus from the mathematical equations derived from the rock mechanics text and elasticity theory strain behavior can be understood. It is depending on the thermal stress condition and related parametric sources to be developed in possible direction.

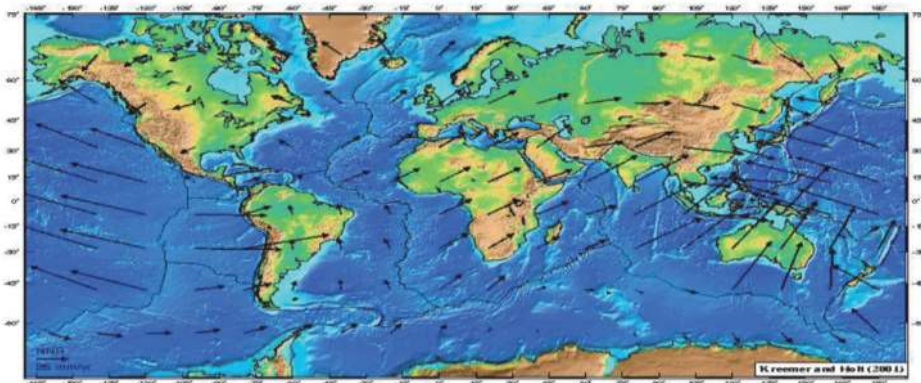
Citing Sources: GSRM data from EHolt and A (Zhao (1997–2002)<sup>14</sup> [7, 9, 17, 23].

**Figure 8** Above states the nature of strain against impending stress on the quartzite rocks observed by Bienweiski [24] we infer from the stress: Strain relationship whatever the type of stress Litho static-or deviatoric shearing (axial) or normal the effect on the rock surface of the stratum<sup>15,16</sup> [8, 9, 16, 17].

## 2. Data acquisition

**Figure 3** is the strain rate measurement involving GSRM map from E Holt and Zhao Zheng.

**Figure 4** displays the 25000 grids distribution on the global map. Entire network of strain rate or velocity vectors shows expansion and contraction due to upwelling stress from the (mantle-up-lr) interface. Interesting point is that most of velocity

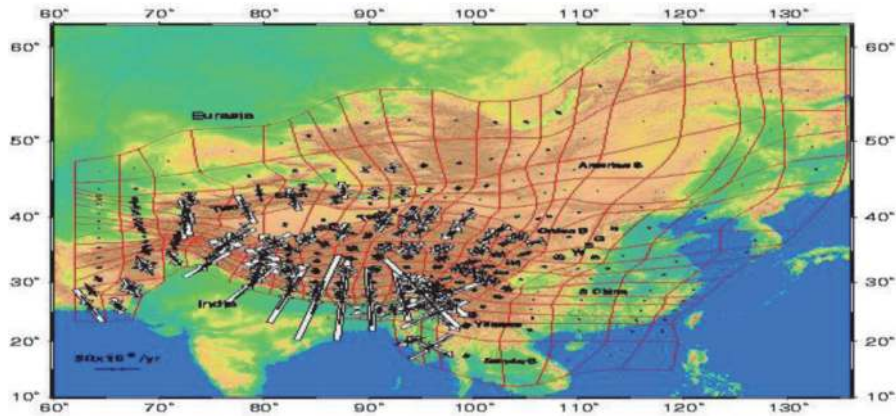


**Figure 3.**  
 Courtesy; E.Holt (2004) for strain rate measurement on GSRM.

<sup>14</sup> In the Eq. (12) pressure over rock body is calculated as the sum of stress due to thermal convective current in all three x,y,axes direction and with joint effect of poisson ratio and thermal gradient and expansion coefficient is attributed.. as per reference dalt in [4, 7–10, 16–18, 23].

<sup>15</sup> E Holt and A Zhao (1997–2002) have worked over assembling global strain Rate measurement data in form of vectorial notations in size and direction wise as in the **Figures 2-8** which have been discussed in the Refs. [7, 9, 17, 23] of bibliography.

<sup>16</sup> Rock strata experience stress interaction in upward progression of deviatoric (shearing) or confining (Lithostatic stress).it has been detailed by Bienweiski, [24] in his literature for stress behaviour over Quartzite formation. Can be referred in [8]. Elastic anisotropy of regularly jointed media [18].



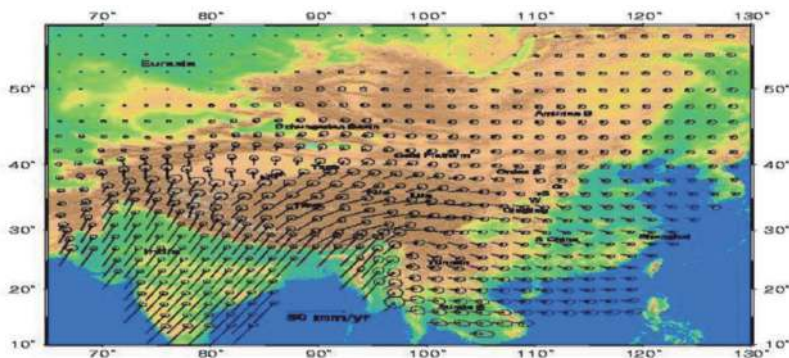
**Figure 4.**  
Global Strain Rate Measurement courtesy Zhao.

vectors on the Asian continental plates are in contracting mode. Vectors at the oceanic plates are longer and in expanding mode. It is obscure about the stress stored below the crustal reservoir having contracting mode and stress energy already been consumed at the expanding region. It has been significantly observed during the 18th September, 2011 outbreak at Sikkim (6.8 Mw) and Turkey 7.2 Mw on October 24th 2011.

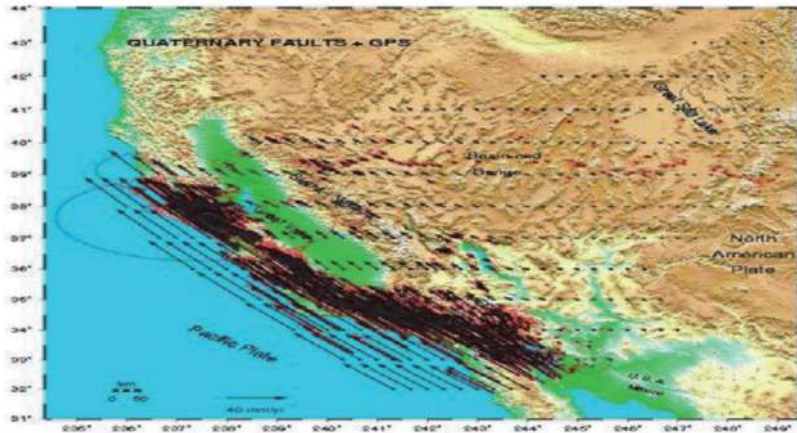
In the **Figure 5** velocity vectors are due north and NE on Indian subcontinent and Tibetan plateau region, respectively. Vectors show the Indian plate moving towards the Tibetan plate. Eurasian plate remains passive w.r.t. Pacific and American Plates. It has been evident even by the Harvard CMT catalog data set. From Jan 1977 to November 2002.

**Figure 6** shows the pattern of strain rate or vectors with greater in amount than the vectors at continental plates of America with respect to Pacific. Eventually has been observed by the events of Chile 7.3 Mw on 2nd Jan 2011 and Mexico 6.5 Mw on October 2011. Vectors are shorter at the continental region than that of Oceanic region of Pacific. This has been evident even by the Harvard CMT data catalog since Jan 1977 to Nov 2002 (**Figure 7**).

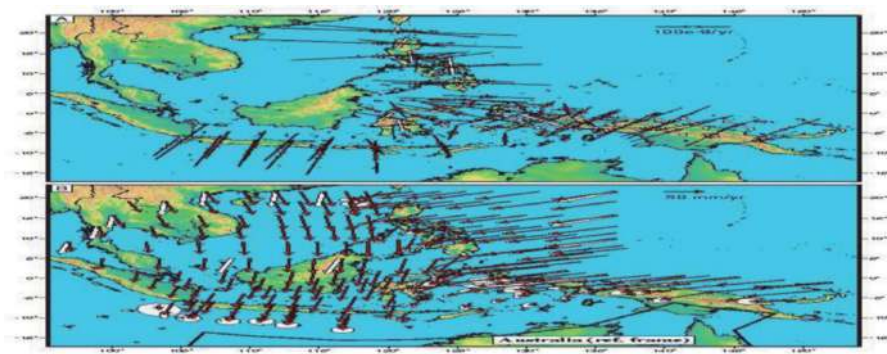
**Figure 8** above states the nature of strain against impending stress on the quartzite rocks observed by Bienweiski [24] we infer from the stress–strain relationship whatever the type of stress Litho static-or deviatoric shearing (axial) or normal the effect on the rock surface of the stratum depends on the parameters.



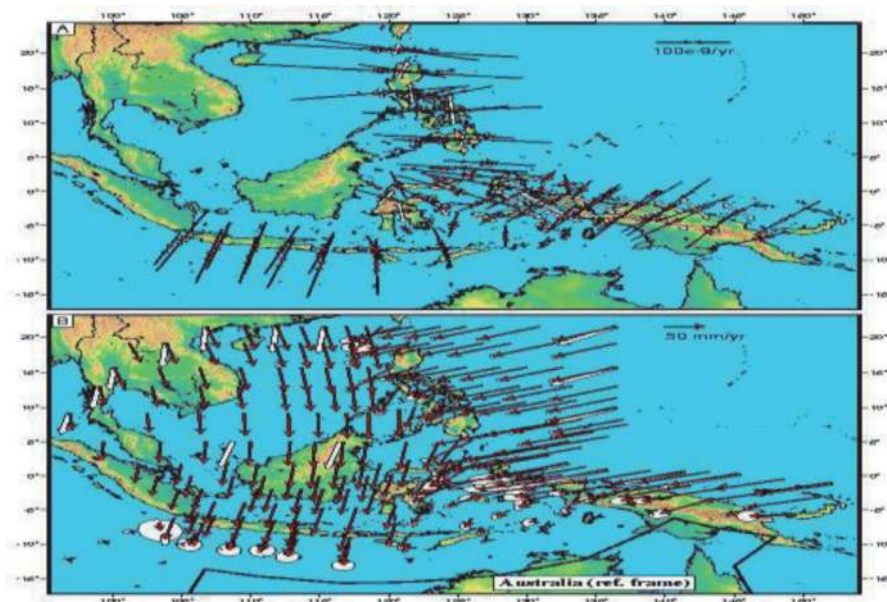
**Figure 5.**  
The supportive evidence of concept laid in the abstract.: Courtesy: Zhao et al. Kreemer et al. [25] strain rate measurement for the Tibetan and Asian region prior to Sikkim (2004) 5.7Mw event.



**Figure 6.**  
Velocity vectors of Pacific plate against American fixed plate (relatively) courtesy: Almindger Zhao et al. (1998, 2004).



**Figure 7.**  
The direction and amount of vectors in the oceanic region of Indian and Pacific plates with relative passiveness of Asian plate.



**Figure 8.**  
Courtesy; by E. Holt (2004) for strain rate measurement on GSRM.

Characters like rigidity  $G$ , elasticity  $\epsilon$ , density  $\rho$ , Poisson ratio  $\nu$  coefficient of thermal expansion  $\alpha$ , thermal diffusibility  $\beta$ .

**Figure 7**; ISAR Interferometry; Price and Sandwell [17] for event of Landers, California Earthquake (7.3 Mw) on June 28, 1992 [18, 19].

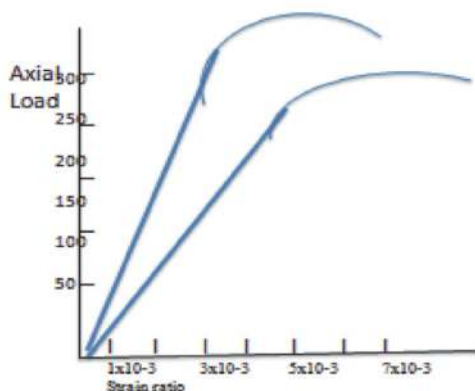
**Figure 2** is an attempt to explain the nature of strain produced to impending principal (deviatoric) stresses in the horizontal plane over the stratum rock unit (**Figures 8 and 9**).

**Figure 3** is the data acquired from the GSRM map worked out by E Holt and zhaon Zeng 1979 et al.

**Figure 4** displays the 25000 grids distribution on the global map. Entire network of strain rate or velocity vectors shows expansion and contraction due to upwelling stress from the (mantle-up-lr) interface. Interesting point is that most of velocity vectors on the Asian continental plates are in contracting mode. Vectors at the (**Figures 10 and 11**) shows the application frequency range of the circuit to replace the inductance.

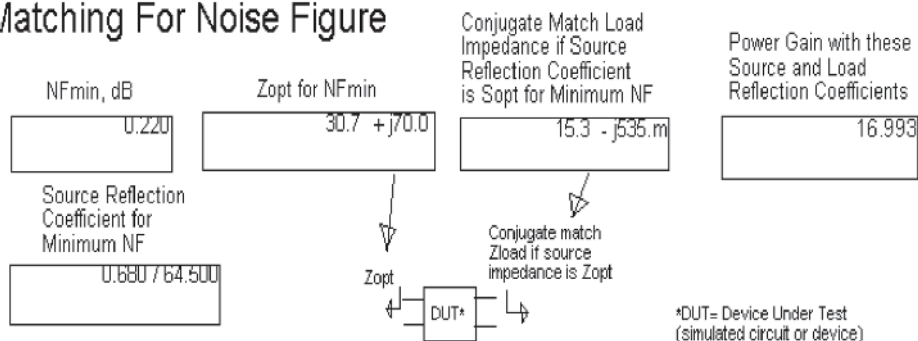
**Figure 12**: velocity vectors of Pacific plate against American fixed plate (relatively) courtesy: Almindger Zhao et al. (1998, 2004) **Figure 6** shows the pattern of strain rate or vectors with greater in amount than the vectors at continental plates of

### Nature of strain over impending stress on Rock sample in LABORATORY

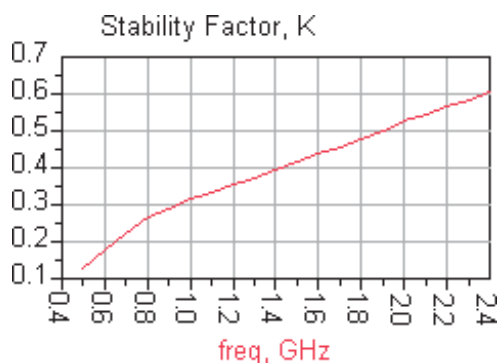


**Figure 9.**  
Courtesy: Fundamentals of [19].

### Matching For Noise Figure

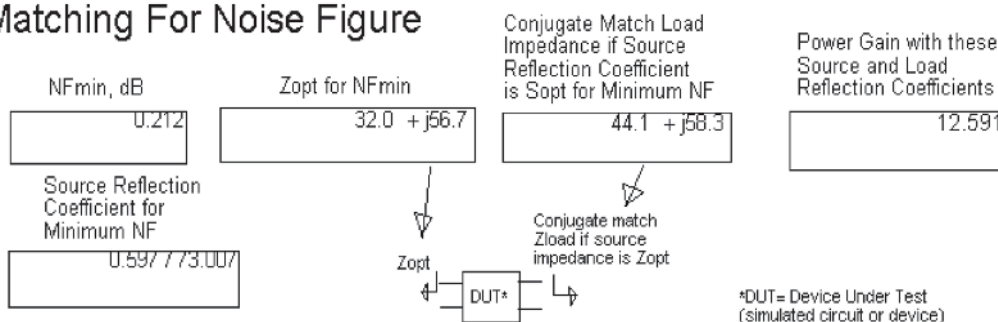


**Figure 10.**  
ATF34143 best noise matching conditions.



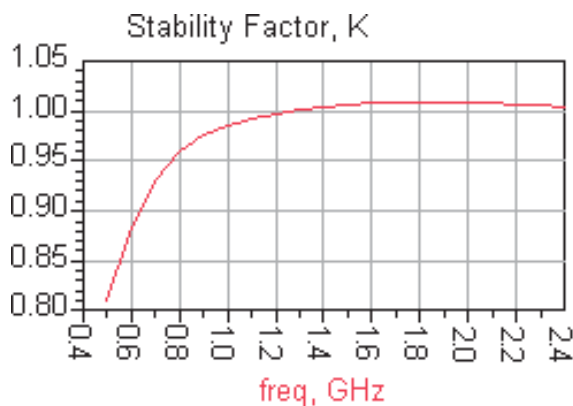
**Figure 11.** ATF<sub>34143</sub> stability analysis results. (a) Increase the inductance at the source to make the circuit stability greater than 1 in the application frequency range, and then replace the inductance with a microstrip line.

### Matching For Noise Figure

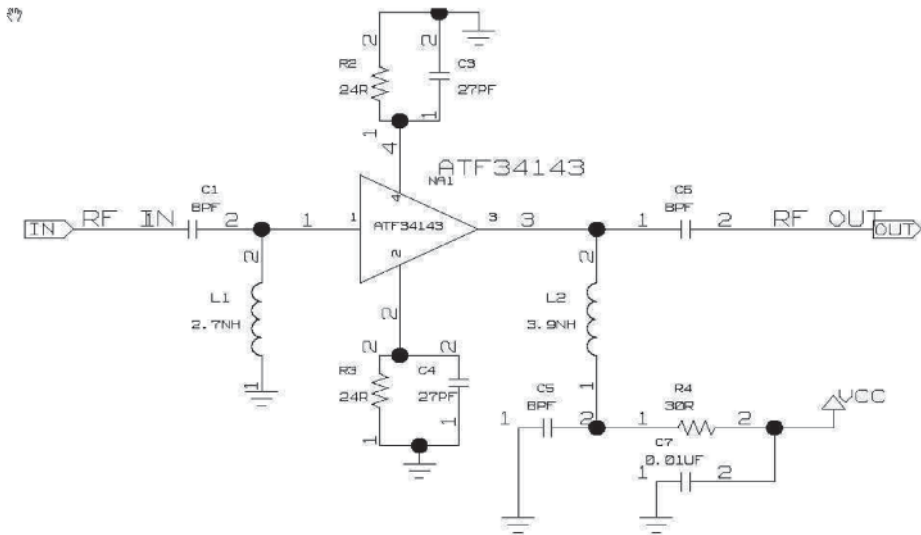


**Figure 12.** ATF<sub>34143</sub> the best noise matching under the condition of increasing source inductance.

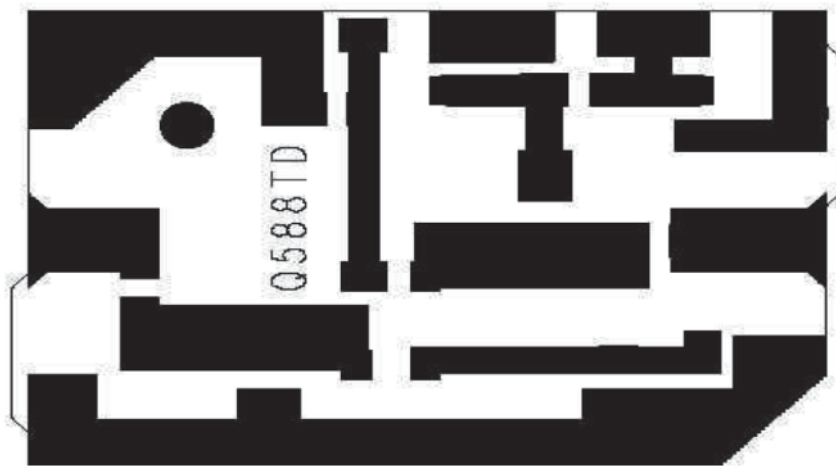
America with respect to Pacific. Eventually has been observed y the events of Chile 7.3 Mw on 2nd Jan 2011 and Mexico 6.5 Mw on October 2011. vectors are shorter at the continental region than that of Oceanic region of pacific. This has been evident even by the continental plates of America with respect to Pacific. Eventually has been observed y the events of Chile 7.3 Mw on 2nd Jan 2011 and Mexico 6.5 Mw on October 2011. vectors are shorter at the continental region than that of Oceanic region of pacific. This has been evident even by the Harvard CMT data catalog since Jan 1977 to Nov 2002 (**Figures 13–16**).



**Figure 13.** ATF<sub>34143</sub> stability results with increased source inductance.



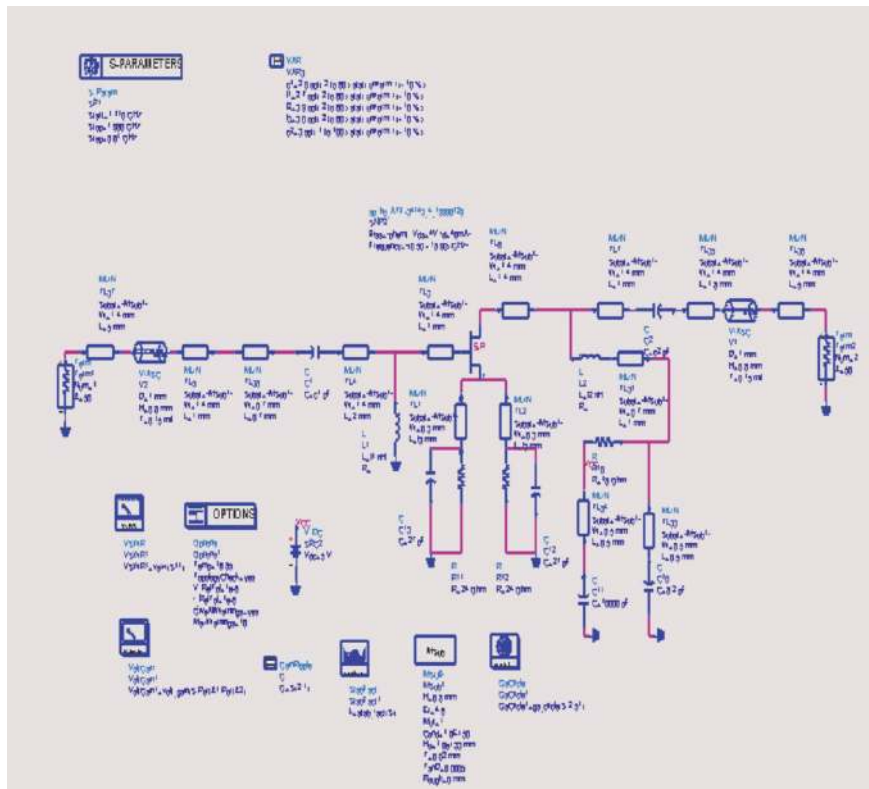
**Figure 14.**  
Initial electrical schematic.



**Figure 15.**  
Double-sided PCB layout (the bottom layer is a large area grounding).

### 3. Conclusion

It is proved that Amount and direction of velocity vectors or strain rate is proportional; to the quality and quantity of the stress impending. Shorter vectors signify of stored seismic energy at the reservoir of stratum. And hence characterizes of shallow focus expectation. An III vector of medium size signifies of outbreak stress drop at medium depth. All the vectors aligned in one direction and with same magnitude it is characteristic of stress line (tangential or radial perpendicular to the vectors observed At right angle to the vectors pattern observed at one region there lies the region of perpendicular stress viz. Tangential –to radial and vice versa. Vectors at these two region shows perpendicularity in relation. Velocity vectors of shorter size in general characterizes of foreshocks of seismicity at the region. Whereas larger size signifies greater magnitude of seismicity as in china 1996 with 7.5 Mw. Expectation of epicenter and focus lies better at the terminal point of



**Figure 16.**  
 Electrical schematic of PCB simulation.

smaller velocity vectors. Smaller vectors are characteristics of higher magnitude and Intensity of seismicity at the place of observation. If any motion occurs at source of waves then some surface currents are induced on some parts of the earth since the earth includes inhomogeneous materials; i.e., including conducting and/or non conducting bodies and/or free spaces, etc. in some locations. If any part of these materials makes a deviation then those surface currents variate with respect to time.

The assumption for the fact gives the result below: The Lorentz's forces, which are applied on varying currents due to the geo electromagnetic field appear at least. A new force [2] additional to Lorentz's force has to be observed due to the irregularities, too. This additional force has to have a very small magnitude around source of waves, but it has to have an irregularly and non-smoothly deviating character, so it propagates with increasing-decreasing in magnitude with some periods according to some transfer rules of forces in bodies. The modernized physical mechanism beyond the earthquake phenomena is explained with the above mentioned approach. The fact behind the earthquake phenomenon is postulated. Restrictions at the use of some specific frequency values are necessary to the frequency spectrum used in systems all around the earth to realize a successful prediction.

## Acknowledgements

I give my gratitude and obligation are bid to Author cited in the reference section for their prior and later permission for theirs; reference figure and data viz.; Dr. E. Holt; Stony Brook University New York.

I offer my special thanks and gratitude to Wiley publications for citing the mathematical equations for principal section of paper. I must acknowledge to Dr. P. V.S. Raju, Head, Department of Centre for Ocean and atmospheric Sciences and Technology Amity University Jaipur India, support to carry out the research.

Last but not the least I must acknowledge to INSAR and SLR satellite agency of NASA for providing satellite imagery and data set for 28 June 1992 California landers, event of seismicity.

## **Acronyms and abbreviations**

GSRM	Global Strain rate Measurement
GPS	Global positioning System
COAST	Centre for Ocean and atmospheric Sciences and Technology
CSEP	Collaborative study on earthquake Probability
SAR	Satellite acquired Ranging

## **Author details**

Umesh Prasad Verma<sup>1</sup>, Madhurendra Narain Sinha<sup>2</sup>, Pushan Kumar Dutta<sup>3\*</sup> and Subhra Mullick<sup>4</sup>

1 COAST Jaipur Amity University, Rajasthan, India

2 School of Engineering, Amity University, Kolkata, India


3 Geology Department, Patna University, Patna, India

4 Geological Studies Unit, Indian Statistical Institute, Kolkata, West Bengal, India

\*Address all correspondence to: [pkdgeoindia@gmail.com](mailto:pkdgeoindia@gmail.com)

## **IntechOpen**

---

© 2021 The Author(s). Licensee IntechOpen. This chapter is distributed under the terms of the Creative Commons Attribution License (<http://creativecommons.org/licenses/by/3.0>), which permits unrestricted use, distribution, and reproduction in any medium, provided the original work is properly cited. 



## References

- [1] Allmendinger, R. W., Royse Jr, F., Anders, M. H., Christie-Blick, N., & Wills, S. (1995). Is the Sevier Desert reflection of west-central Utah a normal fault?: Comment and Reply. *Geology*, 23 (7), 669-670.
- [2] Allmendinger, R. W., Reilinger, R., & Loveless, J. (2007). Strain and rotation rate from GPS in Tibet, Anatolia, and the Altiplano. *Tectonics*, 26(3).
- [3] Muskhelishvili NI (1963) Some basic problems in mathematical theory of elasticity. Noordhoff International Publishing, Leyden
- [4] Eringen, A. C. (1967). *Mechanics of Continua*. Jhon Wiley and Sons. *New York*.
- [5] Timoshenko, S. and J.N. Goodier, *Theory of Elasticity* (McGraw- Hill New York, 1970).
- [6] Thatcher, W. (1975) Strain accumulation and release mechanism of 1976 San Francisco earthquake; *J. Geophysics.Res.*80,4,862-4,872.
- [7] Mushkevili, N.I., *Some basic Problems of Mathematical Theory of elasticity*, 4th Ed. (P. Noordhoff, Groningen, 1963)
- [8] Morland, L. W. (1976). *Elastic anisotropy of regularly jointed media*.
- [9] P. L. Israelevich Y. Yair, A. D. Devin, J. H. Joseph. Levin, I. Mayo.M. Molem, Transient airglow enhancements observed from the space shuttle Columbia during the MEIDEX sprite campaign *GEOPHYSICAL RESEARCH LETTERS*, VOL. 31, L06124, doi: 10.1029/2003GL019110, 2004.
- [10] Dziewonski, A. M., Chou, T. A., & Woodhouse, J. H. (1981). Determination of earthquake source parameters from waveform data for studies of global and regional seismicity. *Journal of Geophysical Research: Solid Earth*, 86 (B4), 2825–2852.
- [11] Holt, W. E., Kreemer, C., Haines, A. J., Estey, L., Meertens, C., Blewitt, G., & Lavallée, D. (2005). Project helps constrain continental dynamics and seismic hazards. *Eos, Transactions American Geophysical Union*, 86(41), 383-387.
- [12] Zhao, J., Broms, B. B., Zhou, Y., & Choa, V. (1994). A study of the weathering of the Bukit Timah granite part A: review, field observations and geophysical survey. *Bulletin of the International Association of Engineering Geology-Bulletin de l'Association Internationale de Géologie de l'Ingénieur*, 49(1), 97-106.
- [13] Kreemer, C., Holt, W. E., & Haines, A. J. (2003). An integrated global model of present-day plate motions and plate boundary deformation. *Geophysical Journal International*, 154(1), 8-34.
- [14] Marrett, R., & Allmendinger, R. W. (1990). Kinematic analysis of fault-slip data. *Journal of structural geology*, 12 (8), 973-986.
- [15] Shen Tu, B. W. E. Holt, and A. J. Haines, deformation kinetics in the western Un determined from the Quaternary slip rate and recent geodetic data. *J. Geophysics*, 28955, 1999.
- [16] Price, E. and D. T. Sand well (1998): Small scale deformations associated with the 1992 Landers California earthquake mapped by synthetic aperture radar interferometry, phase gradient, *J. Geophysics*, res.103, 27,001-27,016.
- [17] Price, E. and D. T. Sand well (1998): Small scale deformations associated with the 1992 Landers California

earthquake mapped by synthetic aperture radar interferometry, phase gradient, *J. Geophysics*, res.103, 27,001-27,016.

[18] . Savage .J.C. and R.O. Bur ford (1973) geodetic determination of relative plate motion in central California, *J, geophysics*, Res. 103, 832–845.

[19] Jaeger J.C. and N.G.W. Cook: *Fundamentals of Rock Mechanics* (Chapman and Hall, London,(1976)

[20] F.A. Levinzon, “Ultra-low-noise seismic piezoelectric accelerometer with integral FET amplifier,” *IEEE Sensor Journal*, 12(6), 2012.

[21] Zechar, J. D., & Jordan, T. H. (2008). Testing alarm-based earthquake predictions. *Geophysical Journal International*, 172(2), 715-724.

[22] Smith, D.E.etal.(1990) ;Tectonic motion and deformation from satellite laser ranging LAGEOS, *J Geophysics Res*, 95,22013–22041.

[23] Pondrelli, S. A. Morelli,G. Ekstrom, S. Mazza, E .Boschi, and A.M. Dzeinweski, *Eu Mediterranean regional centroid moment tensors:1997–2000*, *Phys, earth and planet* 2002.

[24] Bieniawski, Z. T. (1967). Stability concept of brittle fracture propagation in rock. *Engineering Geology*, 2(3), 149-162.

[25] Kreemer, C., Haines, J., Holt, W. E., Blewitt, G., & Lavallee, D. (2000). On the determination of a global strain rate model. *Earth, Planets and Space*, 52(10), 765-770.