

HCI Design Patterns for Mobile Applications Applied to Cultural Environments

R. Tesoriero, J. A. Gallud, M. D. Lozano & V. M. R. Penichet
*University of Castilla-La Mancha
Albacete, Spain*

1. Introduction

Nowadays, mobile activities such as entertainment, commerce (m-commerce) or learning (m-learning) are being increasingly adopted by people. A new activity being explored in mobile computing is the support of Augmented and Immersive Reality (A&IR) features on public physical spaces (shops, libraries, museums, etc). The adoption of these new technologies is due to the physical space constraints to display information and the information media support restriction to text and images, because synchronous media, as audio and video, are difficult to play in public spaces (people must be “synchronized” at the beginning of the reproduction to be meaningful). This situation is very common in museums and art expositions. Each art piece has lots of information associated to it, but only a small part of this information is available to visitors.

People in charge of museums and libraries started using electronic technology more than 20 years ago. It began with electronic libraries and was intensified with the introduction of Web technologies offering new opportunities to open up the walls of the museum to the world (Schweibenz, 1999) (Dolgos, 1999) (Falk & Dierking, 1992) (Jackson, 1998) (McKenzie, 1998). Some authors (Léger, 2004) (Georgiev et al., 2004) (Elliot & Phillips, 2004) (Gary & Simon, 2002) suggest that m-commerce and m-learning are the “next step” of Web applications. This tendency will be soon reflected on museum electronic guides. Following the emerging notation, we refer to this kind of applications as m-space applications (mobile applications for physical spaces).

The application of mobile technologies to museums and exhibition environments has been an area of special research interest in the last years. There are numerous approaches and applications that employ location awareness techniques to retrieve information from art pieces and exhibition rooms (Bristow et al., 2002) (Ciavarella & Paternò, 2004) (Gallud et al., 2005). Although some of these approaches seem to be suitable for small museums, it may result expensive in large deployments.

In this sense, we propose an alternative approach to location-aware applications based on an intuitive classic user interface that allows visitors to retrieve information from the physical environment. This alternative is based on HCI design patterns because they seem to be the appropriate tool to solve recurrent problems in this area. This proposal can be used together

with different cultural space solutions or location awareness techniques. A particular solution is employed to evaluate the catalogue of interaction design patterns proposed. Thus, this chapter starts presenting related work in museums guides and design patterns. Sections 3, 4, 5, 6 and 7 expose a catalogue of HCI design patterns organized in categories. Later, in section 8, we describe how patterns are applied in a real scenario and an evaluation of the improvements based on design patterns is presented. Finally, we expose the conclusions and future work.

2. Related Work

This section exposes the origins of the application of design patterns to the computer science discipline. Then we present a set of HCI design patterns catalogues that are related to our work. Next, we define a mobile design patterns catalogue. Finally we present our conclusions about previous works.

In the late seventies Christopher Alexander (Alexander et al., 1977) studied how people interacted with physical spaces and found a new method of architecture and scheduling. Alexander exposes that life is about patterns of events and the architecture that supports these patterns help us to feel better.

Alexander said that “A pattern language is really nothing more than a precise way of describing someone’s experience of building”.

Alexander kept these observations using a format, known as “design pattern”. Thus, a design pattern summarizes the context of a problem and its solution. It should be concrete enough to be used as a rule of thumb with good results, and yet sufficiently abstract to be applied to countless situations. So a “pattern language” is a group of “design patterns”.

However, the concept of pattern languages was firstly adopted by the programming community in computer science. The most important contribution in this field is the book “Design Patterns: Abstraction and Reuse in Object-Oriented Designs” (Gamma, E. et al, 1995). The book describes solutions to common software design problems defining four essential elements that feature design patterns.

The **name** of the pattern identifies it and is used to describe a design problem, the solutions and the consequences in a word or two. Giving names to patterns increases vocabulary and allows us to get a higher level of abstraction. The **problem** describes when the pattern should be applied explaining the problem and the context it solves. The **solution** describes the elements that are part of the design, the responsibilities and collaborations. It does not describe a concrete solution; it is like a template that can be applied in different situations. The **consequences** are the result of applying the pattern to solve a problem. They expose the advantages and disadvantages of the solution proposed. They also include the impact on flexibility, extensibility and portability of the system.

This work groups patterns on categories according to the problem they solve. It defines three categories: creational patterns, structural patterns and behavioural patterns. Each pattern belongs to only one category.

Communities related to HCI adopted Alexander ideas too. One of the first attempts to define design pattern collections applied on HCI was the book “Common ground: A Pattern Language for Human-Computer Interface Design” (Tidwell, 1999).

These general purpose patterns were loosely coupled. It means that each pattern may belong to more than one category. To organize them they were grouped into primary patterns and sublanguages.

There are primary patterns related to content and actions. There are also patterns related to the deployment of content and actions, and patterns that describe the basic form of content and actions, how available actions are shown to the user, how the space and user attention are used, how the content is organized in working surfaces, how the user is able to navigate, what are the actions the user is able to carry out, how the user is able to modify the interface, how to achieve a clean and attractive interface and how the interface is able to support user tasks.

An evolution of this seminal work was published in a new book entitled "Designing Interfaces: Patterns for effective Interaction Design" (Tidwell, 2005). This publication presents patterns in a general way, organized in "pattern languages".

She grouped patterns according to the function they perform on the interface, as follows: organizing the content, getting around, organizing the page, commands and actions, showing complex data, getting input from users, builders and editors and making it look good.

Other collections and languages followed, for instance, Martijn van Welie's work "Interaction Design Patterns" (van Welie & Trätteberg, 2000). In this case patterns were organized according to interface types (Web Design Patterns, GUI Design Patterns and Mobile UI Design Patterns). Within these categories, these patterns are grouped by the functionality they provide. These patterns are close related to the usability concepts: visibility, affordance, natural mapping, constraints, conceptual models, feedback, security and flexibility.

In (van Walie et al., 1999) there are some usability conditions that are related to learnability, memory, performance, error rate, satisfaction and task completeness. According to these indicators, to describe a design pattern the following elements are used: the problem that is related to categories defined by (Norman, 1988), the usability principle that was also defined by (Norman, 1988), visibility, affordance, constraints, models, feedback, security, flexibility, context, solution, rationality, performance, learnability, memory, satisfaction, completeness rate, errors and samples.

Another interesting book related to patterns in HCI (Borchers, 2001) and recently a complete collection of patterns oriented to Web site applications by the same author.

Design patterns were also applied to mobile applications. For instance, in (Roth, 2002) Roth defined classes of patterns (as pattern languages or categories) related to mobile interaction. He groups patterns in the following classes: security, authentication, streaming, mobile service, mobile code, mobile data and user interface. Within the UserInterfaces class, he grouped patterns related to UI interaction patterns of mobile applications.

Design patterns are the natural choice to represent a generic solution in the design of user interfaces related to mobile applications for cultural spaces because: (a) The domain model of the problem we want to solve is closely related to architectural problems, the origin of design patterns, (b) They have been successfully applied in computer science for years and they have proved to be a good solution to common problems and (c) Design patterns are also applied in two fields that are closely related to the one we tackle, the HCI and mobile computing field.

Based on these facts and the need to solve the problem of designing an intuitive and natural interface that allows users to retrieve information from the environment through a mobile device, it is logical to think about defining design patterns for mobile devices to browse information related to physical objects in physical spaces. In the next section we present our proposal of HCI mobile design patterns.

3. HCI Mobile Design Patterns for m-space applications

Before introducing design patterns, we will introduce the concept of m-space applications. These applications are a subset of mobile applications that are designed to browse information related to physical spaces (buildings, floors, rooms, halls, etc.) and the objects that these spaces contain.

Examples of this kind of applications are the museum tour guides. These guides show information about the art pieces the museum exhibits.

In this section we present the characteristics of design patterns for m-space applications. Patterns emerge from the experience of solving problems in real scenarios. We have based the construction of this pattern catalogue on usability evaluations (Tesoriero, 2007) performed in a real m-space system, the Cutlery Museum of Albacete or MCA (Gallud, 2005).

Analyzing the usability evaluations, we detected some problems related to HCI using a PDA running in the MCA system. To solve these problems we designed a brand new user interface.

From this interface design, we extracted a set of HCI design patterns that were defined to solve related to the design of m-space applications. These patterns were introduced in (Tesoriero et al., 2007c).

Mobile devices do not have the processing power neither the screen resolution of desktop computers, so the information to be presented to the user should be carefully organized. Some advantages of implementing m-space systems are:

- **The improvement of information availability in physical spaces:** Information that is not available in a physical form (a text panel or a photo) may be so virtually.
- **The provision of physical context to the information:** The information is easily assimilated if there is a physical representation that is associated to it.
- **Information update:** Information is easily updated in a virtual form. For instance, it is cheaper and quicker to change the information stored in a database than the information displayed in a text panel.

Examples of public spaces that can take advantage of this type of applications are museums, libraries, shops etc.

When building these applications, there are some aspects that should be carefully designed to keep the application simple, intuitive and easy to use. Based on our experience we have summarized the findings and the lessons learned in the following list:

- It is vital to reflect the user position and orientation into the interface to keep the virtual/physical synchronization between the real and virtual location of the user.
- Mobile devices should be manipulated with the least possible effort because users usually are manipulating other objects while using the device.

- People should be able to use their own mobile devices as a guide in physical spaces. Additional information about users may be used to guide them across buildings and rooms.
- Accessibility is a key issue to tackle because mobile devices may become a powerful tool that may help disabled people to interact with the environment.

Once we have talked about the aspects covered by this pattern catalogue, we will describe how these patterns are documented.

We have based the design patterns description on the one given by Roth (Roth, 2002) that is indeed based on Gamma's description.

The elements were used to describe these patterns were:

- **Name:** The name of the pattern should indicate the problem and proposed solution in one or two words.
- **Synopsis:** It is a brief description of the pattern.
- **Context:** Describes the problem to be solved.
- **Solution:** Describes the proposed solution.
- **Consequences:** Describes the advantages and disadvantages of applying this pattern.
- **Schematic Description:** Most patterns described in this catalogue have a generic graphical representation that is represented in this section.
- **Related Patterns:** This section is used to relate patterns of this or other catalogues. We have included relationships to W3C Common Sense Suggestions for Developing Multimodal User Interfaces principles (W3C, 2006), Tidwell's sublanguages (Tidwell, J., 1999)(Tidwell, J., 2005) and Van Welie's patterns¹ (Van Welie, M. & Trætteberg, H., 2000).

We have kept Gamma terminology using the term Category to describe groups of patterns. And we have also found more useful the classification of patterns where each pattern belongs to just one category.

Each category represents a set of related problems. In this sense, we defined four categories as follows:

- **Location:** The set of patterns to keep people situated within the physical space.
- **Layout:** Patterns proposed in this category expose different interface organizations to cope with mobile device screen resolution restrictions.
- **Routing:** These patterns guide users through a physical space.
- **Accessibility:** These patterns help disabled people to explore physical spaces.

The detailed explanation of each design pattern category will be described in sections 4, 5, 6 and 7.

4. Location Patterns

Public spaces, as museums and art exhibitions, are usually visited by people that have not been there before. So, usually they get a feeling of insecurity when visiting these places because they are going through an unfamiliar place.

¹ <http://www.welie.com>

This feeling should be minimized in order to improve user experience into these spaces. To cope with this feeling, mechanisms that improve people knowledge of the place should be provided.

There are many alternatives to achieve these improvements and the most common are web pages, maps and panels. Web pages are good alternative to those people that plan their visit, but it is not practical to those that perform ad-hoc visits. Maps seem to be a good alternative for small spaces that do not have much information to show because they are small and easy to manipulate, but on large spaces and lots of information to expose, this alternative is not the best because of map dimensions. Finally, panels seem to be a good alternative because they are able to expose information about a specific space, and all the information is kept in context with the space it belongs to, but this information may not be available to all visitors because of space restrictions.

However, an application containing information about physical space can be deployed into visitors' mobile device to help them to know the place **while** they are visiting the space. Besides, as this information is displayed individually, a personalized view of the information may be provided to visitors.

To display information according to physical spaces, we have to use a metaphor that relates different levels of spaces (i.e. buildings, floors, rooms, etc.) each other. This relationship seems to be the "contains" relationship because buildings are composed by floors, floors are composed by rooms and halls, furniture is placed in rooms and halls, and each piece of furniture contains objects.

Thus, most of these patterns are based on this relationship to help users get oriented into an unknown space and get more familiar with it. They are used to make visitors aware of orientation and position within a physical space. They also tend to synchronize real space with virtual space creating a virtual representation into mobile device screen that could be easily matched to the real scenario.

4.1 Breadcrumbs

Synopsis: A marquee is used to identify a space into large sets of buildings or floors.

Context: M-space applications present information about a space or object into the mobile device screen. This information should be in context with the space that contains it to keep the user situated into the place.

Large spaces are difficult to explore because there are lots of places to see and most of them have a similar appearance. Consequently, visitors usually get lost.

Solution: This problem could be solved applying a simple concept that is present in our daily life, the address. When we have to locate a house, we usually identify it by its address (street, number, state, country and so on). So, the same idea is applied to physical spaces. For instance, buildings have names, floors have numbers, rooms or halls also have names or numbers, and showcases or concrete objects have a way to be identified too.

A simple implementation of this concept may be achieved by adding a small address bar on the top or bottom of the screen. This bar shows the path of names of the space levels that are required to get to the place is being represented on screen.

An address bar may be composed by the names, in text form, of spaces separated by a symbol that represents the relationship between neighbour spaces.

Besides, the low resolution of mobile device screens leads to a landscape based design to avoid using several rows to expose addresses.

Consequences: The first advantage of applying this pattern is the achievement of visitor location awareness in a simple and direct way. Spaces can be reviewed easily, because the user is able to uniquely name them. Besides, it is useful to perceive how far a user is from a place because any visitor can be aware of distances just by relating two addresses (i.e. two rooms are near if they are in the same floor). It also provides an easy way to identify places or objects to visitors when they are communicating experiences. Finally, as consequence of the last fact, when visitors have to reach a known place, the path name may be used as an implicit guide to reach the destination.

On the other hand, there are some disadvantages of this approach. For instance, it has a direct impact on the screen because it takes some space from screen, particularly when long addresses are needed. Thus, depending on screen resolution, it is probable that space names do not fit in one line.

An alternative to solve this problem is the addition of a second line, but we will be wasting space on information that is probably not used at all times (address information is useful but it should not be the centre of attention of users). Another alternative is based on displaying the lower level space names only, because they are more relevant to visitors; but we are not displaying the whole space context. And, close related to the last alternative is the possibility of including key controls to show this information (right-left, up-down), but buttons are really important resources, and they should not be used unless they were unused. Finally, we can propose a marquee based alternative where text is moving through bar. However, this alternative should not take too much attention of the user.

Schematic Description:

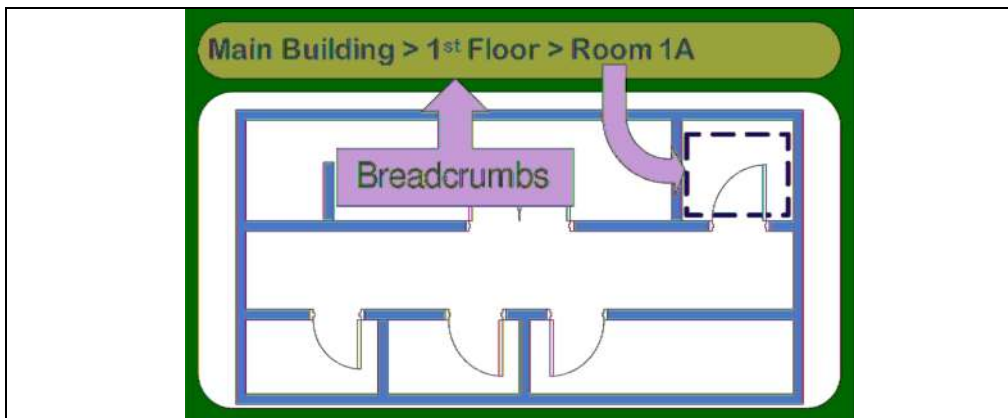

Fig. 1. Breadcrumbs

Related Patterns

Patterns in this catalogue: This pattern is related to Landscape because it provides

Breadcrumbs with a wider space to display path names. A graphical alternative to Breadcrumbs is Multi-Layer Map.

W3C Common Sense Suggestions for Developing Multimodal User Interfaces: This pattern focuses on two principles. The first one is the ability to communicate clearly, concisely, and consistently with users because the information is shown to the user in the same way through all spaces and synchronizes virtual and physical space in some way. The second principle is related to make user comfortable because: it always presents the current status of the system to the user, it also eases stress in the users' short-term memory, and it helps users to know where they are.

Tidwell's sublanguages: It is related to Go Back One Step, Go Back to a Safe Place and Navigable Spaces. Breadcrumbs pattern is used to navigate backwards, one step or any.

Van Welie's patterns: Breadcrumbs is related to its homonymous in Welie Web design patterns group because it is essentially the same idea applied to a physical space.

4.2 Multi-Layer Map

Synopsis: A set of small icons, photos or schemas are used to identify user location into the space.

Context: Some m-space applications are centred on space location (i.e. guide or map applications). It means that the information these applications provide is basically the location of something instead of information about something. When large spaces are composed by spaces that are similar in appearance, the user can easily get lost. Even more, if spaces are not identified. And these applications should avoid this situation. Besides, sometimes users do not know exactly what they are looking for and they just start browsing to find something interesting for them. So, to improve user location awareness a rich space representation is needed.

Solution: A solution to this problem may be based on showing a stack of sketches, images or icons that that represent each level of space hierarchy. This stack displays the path to the lower level space being showed on screen in a graphical way. Generally, it is enough to represent space levels in 2D. However, space representations may be expressed in 3D.

Consequences: The consequence of using this pattern is the possibility to locate objects or spaces in unnamed or unidentified locations, due to the expression richness of the representation. Another good consequence of applying this pattern is the provision to users with "virtual" and graphical distance perception because, if representation is scaled to real dimensions, the user perceives the distance between two points. This pattern can easily be adapted to portable device screen layout design because it can be placed horizontally, on the top or the bottom of screen; or vertically, on the left or on right of screen. Besides, if there is enough screen space and spaces have names assigned, a label indentifying them can be added accordingly to avoid user deducing it. It also provides users with the ability to perceive space neighbourhood. It is a very interesting tool for those that do not know exactly what they are looking for. The main disadvantage of this approach is the amount of screen space this representation takes from screen. It is only advisable if the location is the centre of the application, otherwise Breadcrumbs solution is preferable.

Schematic Description:

Fig. 2. Multi-Layer Map

Related Patterns

Patterns in this catalogue: It is close related to Breadcrumbs pattern because it performs the same functionality, but graphically. If *routes* pattern is applied, the next space to be visited can be easily shown.

W3C Common Sense Suggestions for Developing Multimodal User Interfaces: This pattern focuses on communicate clearly, concisely, and consistently with users because information is shown to the user in the same way through all spaces. It also synchronizes virtual and physical space in some way. It also makes user comfortable because it always present the current status of the system to users, it also eases stress in the users' short-term memory and it helps users to know where they are.

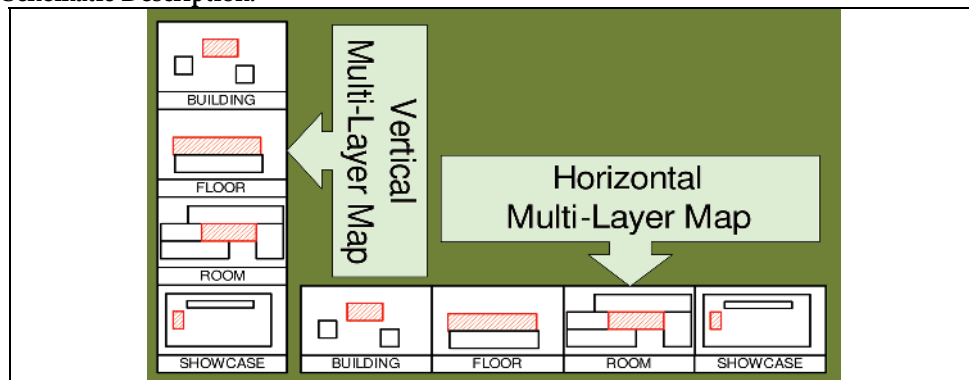
Tidwell's sublanguagues: As this pattern is close related to Breadcrumbs, it is related to Go Back One Step, Go Back to a Safe Place and Navigable Spaces; and it provides a flexible way of navigating across spaces, because you are not showing a path, but nodes on the tree hierarchy.

Van Welie's patterns: This pattern is related to Breadcrumbs in Welie Web design pattern group because it is essentially the same idea applied to a physical space.

4.3 Door at Back (aka Exit)

Synopsis: A sign is drawn into a space representation is used to point the way used by the visitor to enter the space.

Context: There are two types of problems this pattern addresses. The first one is related to large spaces, where people spend lots of time exploring this area. As consequence, they get lost because they get focused on the content of this space instead of the location they are in. The second problem lays on space transitions. A space transition occurs when people pass through one space into another. If transitions occur between spaces that have similar appearance, the user may get confused and probably lost.

Solution: To represent spaces, maps are used. So due to screen resolution restrictions, spaces are represented in many screens that contain information about a portion of a map

describing a space unit (a room, a floor, a building, etc) where users can select subspaces to browse information in them. The solution is based on a simple question that is asked when we get lost in any place: "How did we get in?" To answer this question, we can use the virtual map provided by the virtual device. It can easily provide us with a mark that points the entrance to the space. This mark should match to a physical sign to get the real point into the map at any time. The mark works as an automatic bookmark, when visitors enter to any space, the entrance is automatically bookmarked to go back any time they need it. It is also important to notice that when we come into a space it is preferable to have the entrance mark at the bottom of the map, so when users enters any space the map is automatically oriented according to users' location.

Consequences: The application of this pattern provides users with the ability to get oriented when a space transition occurs. They can match virtual and real scenarios at first sight as soon as they enter the space. Another advantage of applying this pattern is the support for user memory to remember a familiar point. The entrance point of any space is always a milestone providing short stops in the visit that are long enough to avoid keeping user attention more that the necessary, and short enough to avoid users to go a long way back in the visit. However, to implement this pattern, an icon to mark the entrance in the map should be provided. Therefore, the marks in the map may obscure it, even more in low resolution screens; they also may cover other interesting points in the map, and make the map more difficult to read.

Schematic Description:

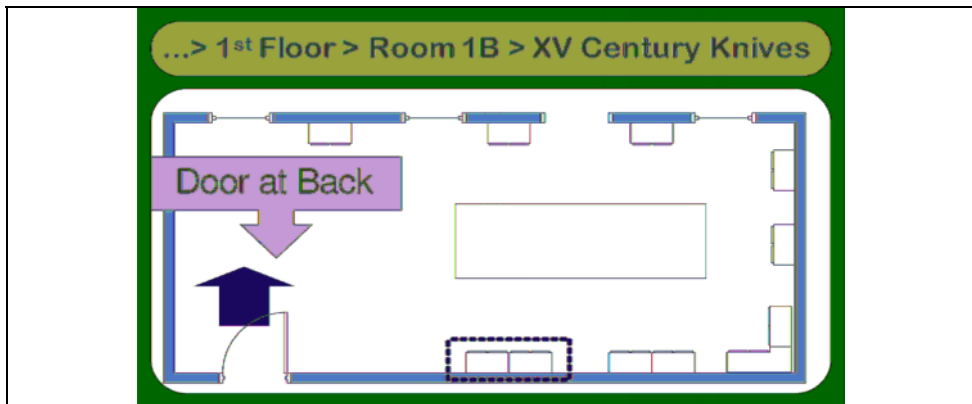

Fig. 3. Door at Back

Related Patterns

This catalogue patterns: This pattern can be used jointly with Breadcrumbs to help users to get oriented in a natural and intuitive way. Besides, it can be combined with layout patterns, such as Vertical-Horizontal layout to adapt screen layout to map shape and Layout Transitions to make users aware of layout changes. Finally, there is a close relationship between this pattern and Signs because they relate real and virtual spaces explicitly.

W3C Common Sense Suggestions for Developing Multimodal User Interfaces: There are three principles that are close related to this pattern. The first one focuses on Satisfying Real-world constraints, as physical and environmental suggestions, due to real space orientation is treated in this pattern. The second one is about communicating clearly, concisely, and consistently with users because a representative icon is placed in the screen to represent user entrance direction (i.e. an arrow). Finally, the third one makes users comfortable by easing users' short term memory because the icon helps users to get "back to the basics" when users enters a room.

Tidwell's sublanguages: The following sublanguages are related to this pattern definition: Go Back One step and Go Back to a Safe Place are related because the arrow is used as a way to go to a safe place and get the user oriented. It is also related to Bookmark because the entrance is automatically bookmarked as a safe place. And, at last, Remembered State because it signals the moment the user entered into the room.

Van Welie's patterns: This pattern can be related to Feedback because user gets oriented based on a previous known position and visibility to solve the user guidance problem. Besides, it improves the Learnability and Memorability aspects of the usability.

4.4 Signs

Synopsis: A real sign matches a virtual representation to the map to identify subspaces.

Context: On large spaces, as rooms or halls visitor may get lost because their attention is focused on the contents of the space. After a while, because of the lack of knowledge of the space, users get lost. Another problem arises when users are looking for something in large spaces filled with lots of objects. To find it they should be able to identify some subspaces within the space in order to locate the desired object. Finally, a common situation that usually affects visitors is getting lost in spaces that present a homogeneous appearance.

Solution: The solution to the proposed problem is based on the point of reference or neighbourhood idea. It means that we identify some places based on the relationship on a remarkable or known place; for instance, the house next to the bank, the statue in middle of the park, and so on. Mobile devices provides maps to identify spaces, so to identify subspaces (i.e. stops) within the space a set of signs is placed in different locations of a room or hall. These signs are also identified in the map by iconic representations. Real signs may be labels, pictures or some remarkable object in the room or hall. Virtual icons representing these objects or signs should be representative of them, to ease the real to virtual matching to users.

Consequences: Users become aware of their own orientation/position virtually and physically just by looking both (the real and the virtual in the map) signs.

This pattern tends to reduce the gap time that users need to get oriented after spending a long time inside a space because the user can easily identify physical objects or location with a map representation in the mobile device screen, achieving A natural and intuitive user orientation. Users are guided across spaces by signals that do not need translation because they are represented in the same way into the map. Besides, if remarkable objects are used as signals, they are identified in the map easily, too. Visitors may use these signs to communicate object locations each other precisely because signals identify subspaces. A

disadvantage of applying this pattern is the possibility to obscure the map with icons and remarkable objects representations. Another disadvantage is the possibility of polluting the physical environment visually with signs. However a solution to this problem is the use of remarkable objects instead of signs.

Schematic Description:

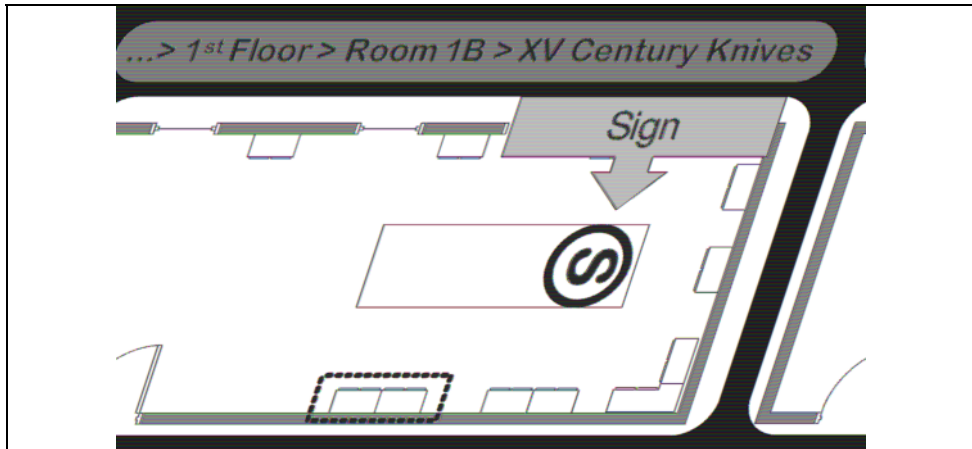

Fig. 4. Signs

Related Patterns

This catalogue patterns: This pattern is close related to Door at Back. The main difference lies on the space application level because Door at back is targeted to solve space transition awareness, and this pattern intent is to cope with long stays in the same space. As a location pattern, it is related to Breadcrumbs and Multi-Layer Map too. All these patterns can be combined providing users with powerful orientation tools.

W3C Common Sense Suggestions for Developing Multimodal User Interfaces: This pattern focuses on communicating clearly, concisely, and consistently with users because it synchronizes multiple modalities appropriately, the real and virtual one. It also makes users comfortable by advertising and suggesting using signs like landmarks, helping them to know where they are.

Tidwell's sublanguages: This pattern is related to Bookmark because it can be seen as a fixed bookmark in the space.

Van Welie's patterns: The only pattern related to this one is Like in Real World because it associates a real life object to a virtual one.

5. Layout HCI Design Patterns

Mobile devices have several resource restrictions compared to desktop computers. One of the low resolution of screen. As consequence, screen organization should be carefully designed. These patterns deal with this problem because they propose solutions to this common situation that usually arises when m-space applications are designed. They exploit

screen dimensions according to the data that will be presented to users. Most solutions in this category are based on a dynamic layout adaptation of the UI components of the screen according to the data they should render. Screen layouts are usually based on two types of information, primary information and secondary information. Primary information is related to the goal of the screen, for instance showing information about an art piece or an object of user interest. On the other hand, secondary information is about information that is useful to the user, but it should not take user attention unless the user is really interested on it. An example of this type of information is awareness information. In order to optimize screen size and resolution, information type should be taken into account to modify screen layout and get the best results.

5.1 Landscape

Synopsis: It applies a landscape based interface design to implement m-space applications

Context: M-Space applications should provide users with information that is not usually available on traditional spaces, for instance, photo galleries, audio and video. Photos are usually wider than higher and videos are usually displayed in panoramic screens. However PDA applications are usually designed to run in portrait position. Besides, people that are visiting public spaces usually carry baggage and they have only one hand free to operate any device. Using a mobile device such as a PDA in portrait orientation requires the user to use both hands to use the keyboard.

Solution: The solution of these problems is the landscape design of mobile device user interfaces.

Consequences: The use of mobile devices in landscape position will provide users with the capability of take advantage of low screen resolution while seeing photos or watching videos. Besides, using PDA in landscape position allows users to hold the device and access cursor controls using one hand only. However, controls and application orientation must be synchronized for right and left handed people. Thus, up and down, and left and right buttons should be swapped to get desired behaviour. Finally, cursor keys are the best way to manipulate portable devices on one hand only and the use of mobile devices in landscape position allows it.

Schematic Description:



Fig. 5. Landscape

Related Patterns

This catalogue patterns: This pattern is closely related to Vertical - Horizontal Layout because the data to be displayed should be optimized to be shown on landscape format. It is also close related to Right-Left Handed Users, because cursor keys should be used by the most skilled hand of the user.

W3C Common Sense Suggestions for Developing Multimodal User Interfaces principles: This pattern focuses on Satisfy Real-World Constraints because most of media information is prepared to be presented on landscape format, so the best way to fit this information is by using this format on screen. Besides, it communicates clearly, concisely and consistently with the user by making the focus consistent across information media by using PDA in landscape position.

5.2 Vertical-Horizontal Layout

Synopsis: This pattern adapts screen layout according to importance of information level to optimize the screen size.

Context: Information to be displayed on portable device screens should be carefully presented to the user because screen resolution is low and screen dimensions are reduced. In this kind of systems, we can define two types of information to be displayed. The primary information fulfils the screen objective. On the other hand, secondary information provides additional information to perform other operations. Primary information shape and size varies; for instance there are photos that should be displayed in portrait or landscape position, videos are usually displayed in landscape position and text is preferably to be displayed in portrait position. So, how should we design the interface to cope with a multimodal interface?

Solution: To solve this problem, we captured the solution proposed by most of video players. When no video is being played, controls are the focus of the application. However, when a video is being played by the player, controls are hidden or they are placed at the bottom of the screen to avoid interference with user attention. In this case, when no video is being played, the primary information is represented by the player controls. On the other hand, when a video is being played, the primary information is represented by the video and secondary information is represented by player controls. The solution is based on laying out the interface according to the shape and size of the primary information. And to optimize screen visualization for main information, screen layout is changed to fit main information the best way as possible. Secondary information is displayed "around" main information where space is available.

Consequences: Primary data information is optimized to fit screen and secondary information is displayed on available space. So, the interface displays the primary information the best way possible. However, secondary information is not sacrificed in pro of primary information space; instead it is placed on where it does not injuries primary information. A disadvantage that presents this approach is the possibility of the user to get confused when layout transformation is applied to interface. For instance, suppose that we are watching a photo in landscape position and we have breadcrumbs on the top, then we want to see a photo in landscape position, and title bar on the right. As consequence, the

user may get disoriented with the interface, because same actions are in different places of the screen.

Schematic Description:

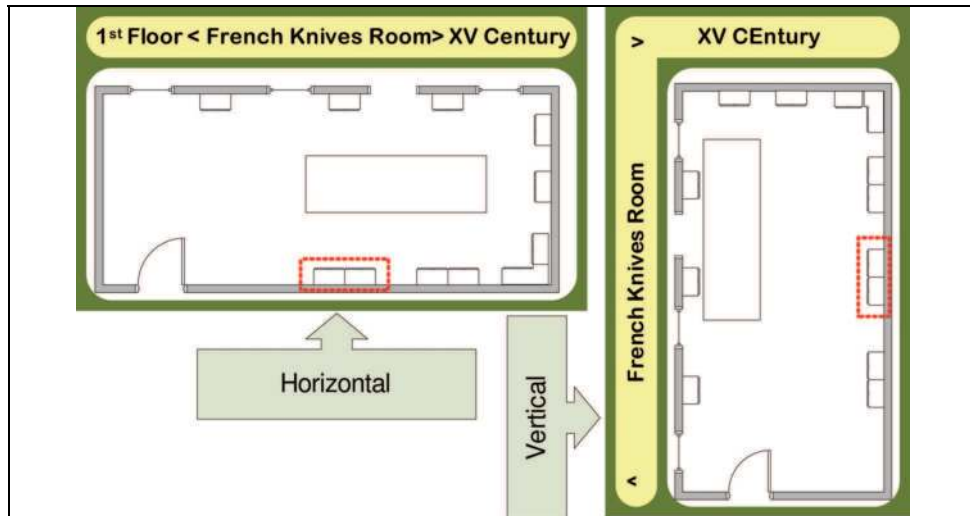

Fig. 6. Vertical-horizontal Layout

Related Patterns

This catalogue patterns: Because this pattern belongs to Layout category, it is close related to Landscape and Layout Transition. Landscape can be applied when video or photos in landscape position are displayed, and portrait when text is being displayed. To address the problem of transitions between different layouts, the Layout Transition can be applied.

W3C Common Sense Suggestions for Developing Multimodal User Interfaces: This pattern satisfies the ability to communicate clearly, concisely, and consistently with users by switching presentation modes when information is not easily presented in current mode. This pattern performs this operation based on primary information requirements. It also suggests keeping the interface as simple as possible because information layout is changed, keeping information to be displayed intact. Besides, this pattern makes users comfortable by reducing learning gap of a new user interface because information to be displayed is the same, only layout is changed.

Tidwell's sublanguages: A sublanguage related to this pattern is Disabled Irrelevant things. Although secondary items are not disabled, they are not treated in the same level of relevance as primary information. Good Defaults sublanguage is also related to this pattern because information default layout changes according to primary information to be displayed.

5.3 Layout Transition

Synopsis: It gives feedback about layout transition to users.

Context: It is a good practice to keep information in the same screen zone to avoid users look for this information every time they need it. However, mobile devices have screen restrictions, so it is important to optimize screen space usage. One of the mechanisms to achieve this goal is the arrangement of data display components according to information to be displayed. However it causes user disorientation.

Solution: The solution is based on two ideas. The first one states that people learn how to operate something based on previous experience. That is to say, if they know how to read temperature from a car dashboard, it does not matter if is on top of speedometer or if it is at the bottom. The second one is based on the fact that people learn quicker when is able to see how a process is performed. As information is usually organized in panels, the layout usually affects these panels and the solution to the problem stated before is based on presenting users a smooth animation of affected panels, providing feedback about the new layout and information distribution of the application. There are many ways to achieve this commitment, for instance, panels may be stretched and enlarged until they get the desired shape. Another way to achieve this goal is using arrows that show the user what is going to happen with the interface.

Consequences: The first consequence of applying this pattern is the achievement of user confidence about what is going to happen with the application. It is really important to note that these transitions also save user learnability time because interface is not changing, it is being transformed. Interface is showing how information is arranged instead of letting users notice the change. However, it introduces a delay into HCI interactions. It is really worthy for beginners, but it may be a little annoying when when expert users are interacting with the application. It is recommendable to allow users enable and disable this application feature.

Schematic Description:

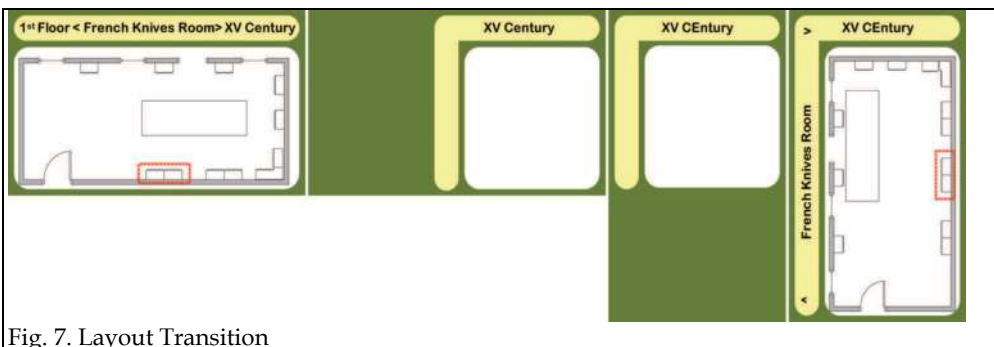

Fig. 7. Layout Transition

Related Patterns

This catalogue patterns: This pattern is very close related to Vertical – Horizontal Layout pattern because it proposes arranging UI components according to importance of information level.

W3C Common Sense Suggestions for Developing Multimodal User Interfaces: It accomplishes the advertising suggestion principle because it encourages the use of animations and sound to show transitions while organizing interfaces, stating that the use of these resources to get users' attention.

Tidwell's sublanguages: This pattern is mainly related to the Progress Indicator because screen layout transformation is a process that is being exposed to the user.

6. Routing HCI Design Patterns

M-space applications are designed to allow users to browse information related to the physical environment they are exploring. The browsing process is based on a metaphor that enables users to match objects and physical spaces to their virtual representation. In this case, we have to match this representation into a mobile device. Mobile devices have screen resolution and processing power restrictions that should be taken into account when virtual representations are used. Navigation across spaces should be natural and intuitive because if they find out that the use of the device is more complicated than performing the same tasks by themselves, the application will be futile. To carry out this goal we present this category of design patterns that groups patterns related to space navigation. These patterns provide, among other important features, user awareness about virtual space navigation controls and location. They also provide different ways of navigation and guidance help for users according to their preferences.

6.1 Free Will Navigation (aka left-right & up-down)

Synopsis: It provides users with access to any virtual space at any level using cursor keys only.

Context: M-Space application objective is to browse and retrieve information about objects and spaces. A key task to carry out this objective is the provision of a versatile, intuitive and natural navigation interface. There are some issues that should be taken into account when designing navigation interfaces for m-space applications. For instance, the importance level of information that the navigation system has assigned is defined as the most important of secondary information. So, it should take enough space to be easily identified by users, but not too much to obscure the main content of the screen. Besides, navigation controls should be natural and intuitive to keep learnability gap to the minimum because it may become useless if users find out that it is easiest to browse information without using the application. Another important issue to take into account is the fact that public spaces are usually accessed by people that are carrying baggage. As a consequence, they have only one hand free at a time to use any electronic device. So, it is necessary to introduce a way to navigate through the m-space application using one hand only.

Solution: The solution is based on the interface presented in most of electronic devices. These devices have shortcuts to most used functions of the device. For instance, MP3 players provide controls to most common operations (play, stop, pause, volume control, etc) directly on the keyboard. However, it does not mean that these are the only operations available, but they are the easiest to access.

Thus, the proposed solution is based on using cursor buttons, available in any mobile device, as navigation controls. Interface is based on a map that shows a virtual space, for

instance a room containing furniture. And, three actions are available; the first one is the selection of any furniture piece of the room; the second one enables users to go into selected furniture to see the objects it contains; and finally, the third one enables users to get out of the room, and get into the floor map to be able to select another room.

Therefore, the same situation is analogous in almost any space level; for instance, you can see a floor map to select rooms or exit to the building to select another floor. Users can also see the building map to select floors, or they can see an object, and select an audio or video associated to such object. Once application interface is defined, key assignments should be performed. For a landscape layout, adapted to right handed people, we propose to use **up** and **down** keys to select an element into the map. In the room example exposed before, we will use these cursor keys to select a furniture piece into the room. The **right** cursor key will be assigned to go into selected space. In the room example it will display a screen to browse the objects contained into the selected furniture piece of the room. And finally the **left** cursor key is used to get out of the map and go into the previous space level. In the room space, this key shows the floor the current room belongs to, so the user is able to go another room. It is recommendable to **label** the arrows representing cursor buttons on screen to provide user feedback about actions.

Consequences: The first consequence is the possibility for users to control the space navigation naturally and intuitively with one hand only using cursor keys. An important issue to note is the possibility to make the proposed combination of keys a standard; making it the “natural key combination” for m-space applications. This fact will drastically reduce the learnability time. Unfortunately, because of the lack of actual standards, labels may obscure map.

Schematic Description:

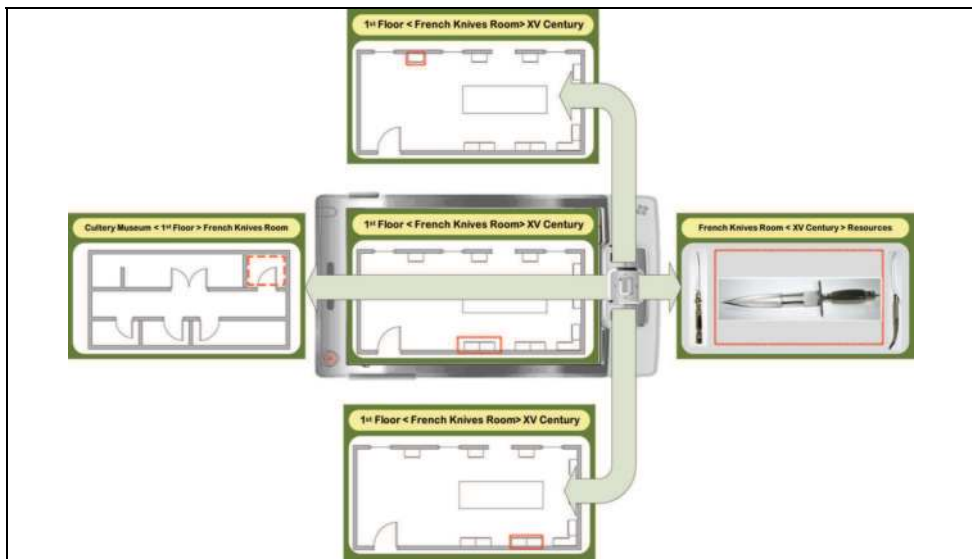

Fig. 8. Free Will Navigation

Related Patterns

This pattern catalogue: Main relationship is established to Landscape Layout pattern because portable devices (such as PDAs) can be used with one hand only, if they are in landscape position. The device should be used with the most skilled hand of the user so it is also related to Right-Left handed users design pattern..

W3C Common Sense Suggestions for Developing Multimodal User Interfaces: This pattern satisfies real-world constraints by assigning cursor keys to most common operations on this kind of applications. It also applies physical suggestions by using one hand only instead of both hands. This pattern also communicates clearly, concisely, and consistently with users by using the same keys through the whole navigation system regarding of space level, keeping interface simple.

Tidwell's sublanguages: This pattern is related to: Optional Detail On Demand because user access the information according to space level, Short description because information about navigation is displayed on screen, and Convenient environment Actions because people usually goes one level up and down only.

Van Welie's patterns: The problems this pattern affords are related to: Visibility because user guidance and navigation can be used to guide users across buildings, Affordance because it uses the space metaphor, and Feedback because operations are labeled. In relation to usability issues, this pattern try to cope with Learnability and Memoability.

6.2 Routes

Synopsis: Routes pattern provides users with predefined routes that guide them according to their interest.

Context: Large spaces are difficult to explore, because they may contain huge amounts of information that is not manageable by visitors. So, information is usually divided according to subjects. This division is not exclusive and cannot be grouped into separate spaces. There are many examples about this situation in museums, for instance, we can group art pieces according the year they were created, or we can group them by author. Sometimes visitors do not have enough time to explore the whole physical space, so they decide to explore the part of the space they are more interested. For instance, a user can decide to see XIV Century Swords instead of all swords.

Solution: The solution is based on the provided in large museums, where visitors can choose a route to follow. This route is related to a specific subject and it guides visitors through the museum where most important art pieces, related to this subject, are exposed. To extend this solution to a mobile device based applications, a bi-panel view is employed. First panel is the **Map panel**. It shows actual space map and navigation control is provided by the application of Free Will Navigation pattern. This map shows the stop points defined by the selected route. Selection keys moves to the next and previous points of visit instead of next and previous object or space within the map. To select the route, you have to swap panels and the **Route selection panel**. To do it, a mobile device key is assigned (usually it is the home key). To disable routes, a special route called Free is used.

Consequences:

First advantage of using Routes pattern is the possibility for users to focus their visit on

part of the information provided by the m-space application. Consequently, it optimizes the visit times and provides an easy way to look for specific objects or spaces in a close range search. Another advantage of applying this pattern is the simplification of device control because only two controls (keys) are needed to navigate across a defined route the **previous** and **next**.

Schematic Description:

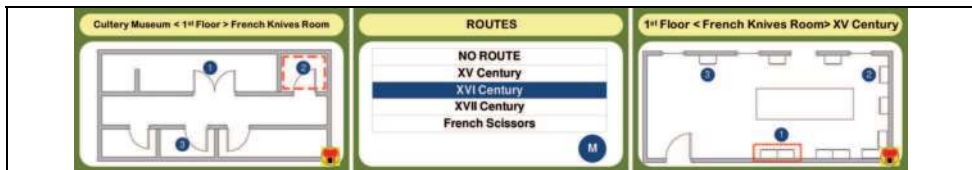



Fig. 9. Routes

The key  is used to switch between views.

Related Patterns

This catalogue patterns: This pattern is close related to Free Will Navigation because when the No Route route is selected, Free Will Navigation is applied.

W3C Common Sense Suggestions for Developing Multimodal User Interfaces: This pattern satisfies real world constraints by suggesting an easy way to perform a task because it allows users to look for a group of related objects. It also communicates clearly, concisely and consistently with users keeping user interface simple because the map is used as a part of routing interface. Finally, it makes user comfortable by improving Human-memory constraints.

Tidwell's sublanguages: We found out this pattern is related to Clear entry points because routes list panel represents a list of entry points of a physical space; Bookmarks because each route can be seen as a list of ordered bookmarks; Convenient Environment Actions because action feedback is shown on screen; Navigable spaces because cursor keys are used to move across stop points; Step by step Instructions because Route navigation can be seen as a sequence of actions; Map of navigable spaces because Routes could be seen as "filtered maps"; Go Back One Step because it allows navigating across spaces; and finally, the Control panel sublanguage is applied on Routes panel too.

7. Accessibility

Public spaces should be available to everybody. An m-space application goal is providing users with a tool to browse and retrieve information from physical spaces. This tool should be available to all people, so accessibility issues are a must of any m-space application. Besides, these applications may provide disabled people with a powerful tool that eases their life because information that could be difficult to reach, due to architectonic barriers, may be available through this type of applications. So, a category that groups patterns dealing with the improvement of m-space application accessibility is defined.

7.1 Space Audio Perception

Synopsis: A voice notifies the user the space he or she has selected or entered.

Context: Blind people cannot see selection or environments from screen.

Solution: We base our solution on voice based interfaces by adding voice awareness to m-space applications when any action occurs.

Consequences: Blind people can enjoy the application and get profit of it.

Related Patterns: It can be used with Free Will Navigation pattern to provide blind users access to application. This mechanism jointly with voice oriented content will provide accessibility to the whole content of the space.

7.2 Right-Left Handed Users

Synopsis: This pattern adapts Landscape based interfaces of m-space applications to be used by right-left handed people.

Context: Usually people do not have the same skills on both hands. So, if an application can be used with one hand only, it is logical that the hand used to perform operations be the skilled one.

Solution: The solution lays on two issues. The first one is mirroring screen horizontally to get the screen view accordingly and the second one is the swapping of cursor keys behavior. **Up** swaps to **down** and **left** swaps to **right**.

Consequences: The most important consequence is the fact that accessibility is improved, and the system can be used by people more efficiently.

Schematic Description:



Fig. 10. Left-Handed users

Related Patterns

This pattern catalogue: This pattern is close related to FreeWillNavigation because it allows left handed people to use device keys with most skilled hand. It is also very close related to Landscape, because it allows users to use mobile device with one hand only.

W3C Common Sense Suggestions for Developing Multimodal User Interfaces: This pattern satisfies real-world constraints because it allows users to use the device in the easiest way to perform a task. Besides it communicates clearly, concisely, and consistently with users because it makes commands consistent. And with organizational suggestions keeps interface simple, too.

Tidwell's sublanguages: We found this pattern is related to convenient environment actions because actions are adjusted to user's perspective. It also improves flexibility by providing explicit control to the user. Finally, this pattern improves learnability and memorability too.

7.3 Zoom

Synopsis: The aim of this pattern is the provision of controls to change font size easily when users are reading documents.

Context: Elder people usually have problems to read documents from portable devices.

Solution: When a text is being shown, it is wrapped and cursor keys to left and right are used to increase - decrease font size. Up and down buttons are used to scroll text.

Consequences: Accessibility is improved, and the system can be used by people more efficiently.

Schematic Description:



Fig. 11. Zoom

8. Applying HCI Design Patterns in an m-space application

In this section we present the evaluation performed to guarantee the validity of these patterns regarding usability issues. To achieve this goal, we have developed a prototype employing the design patterns described in previous sections based on a real m-space application. The former application is completely available to visitors, who can rent a pocket computer (PDA) to explore the museum pieces and spaces, in the Cutlery Museum of Albacete (MCA) in Spain (Gallud et al, 2005). The application of these patterns is exposed in detail in (Tesoriero et al., 2007b). To compare usability issues, a usability evaluation was performed on the original system (Tesoriero, et al., 2007) and then we performed the same evaluation to the prototype. We briefly explain the functionality and interface design of the original system. Then, we describe how design patterns have been applied to build the new prototype. And finally, we compare the evaluation results standing out some final remarks.

8.1 MCA Original System

This section describes the main features regarding the UI of the original MCA m-space application. The diagram depicted in Fig. 12 shows the application UI transitions to explain how people interact with the application. In this diagram, each box represents a screen; arrows represent a transition from one screen to another. Actions that perform a screen transition are identified by a label above the arrow line. An arrow without label expresses an implicit transition (more than one, expresses selection). Once the application navigation has been defined, we will explain the application screens and its main functionality. The system provides four ways of guiding visitors through the space:

The first one is **Recommended Routes** mode. This mode was designed to guide users interested in specific subjects through concrete routes. Samples of these routes are: knives of XVII century or French scissors. To provide this service, a list of recommended routes is displayed to the user. Once a route is selected, the first piece's location is shown on the screen. Users can see the information of the selected piece, by pressing *Ver Pieza* (see Fig. 13a); or can select the next piece according to a defined order, by clicking on *siguiente*; or can go to the previous piece by clicking on *anterior* (see Fig. 13a).

The second one is the **Guided Tour** mode. It was designed as a general purpose route to guide inexperienced visitors through the *whole* building. Functionality and behaviour is identical to a selected route on "Recommended Routes".

The **Access to finder** is used to look for pieces or showcases in the museum. This search can be performed on two ways. The first one is by using piece characteristics (Fig. 13b). The second one is by entering the code of a piece or a showcase (Fig. 13c). Once the search process is concluded, the piece or the list of pieces is shown to the user. If a list of pieces is the result of the searching process, then, users may select pieces to display their information, as shown in Fig. 13g.

The **Unguided Tour** allows users to navigate across the application to get information about pieces and showcases. The information is displayed on levels and three levels were defined: exhibitions, rooms, showcases and pieces. The user interfaces for each level are depicted in Fig. 13 (d), (e), (f) and (g) respectively.

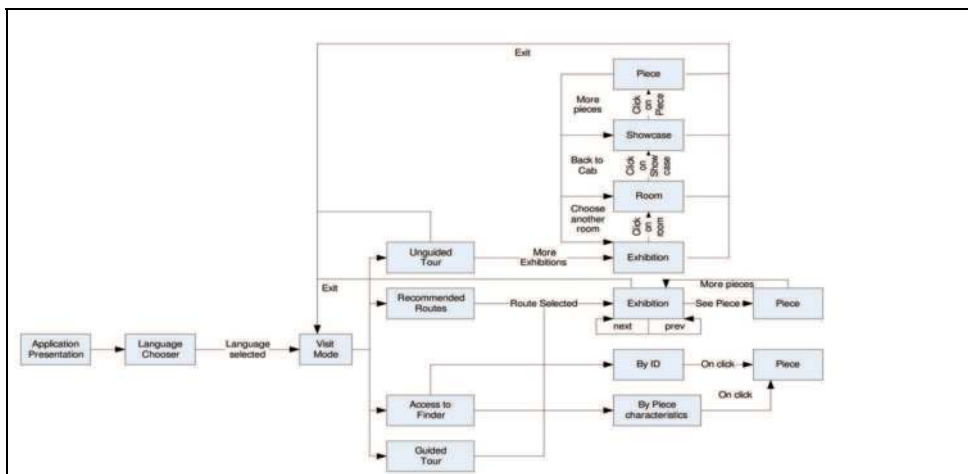

Fig. 12. UI screen transitions.



Fig. 13. UI screen transitions.

8.2 MCA Pattern based Prototype

As the previous version of the system interface, the new one is organized in levels. The first and upper level represents the whole museum (see Fig. 14a). A museum can be composed by several buildings. A building may be composed by several floors (Fig. 14b). A floor may be composed by several rooms (Fig. 14c) and a room may contain some furniture pieces as cabinets or showcases (Fig. 14d). A furniture piece contains objects or art pieces, as depicted in Fig. 14e. Finally, the lower level is defined by piece information, as shown in Fig. 14f.

To navigate across spaces we applied Free Will Navigation.

As Free Will Navigation allows users to control the application using cursor keys only, the application can be controlled by blind people; so if we combine this pattern with Space Audio Perception pattern by adding sounds on space transitions the application can be used by blind people. Free Will Navigation can be combined with Landscape pattern too. So, PDA can be used with one hand only.

Although Free Will Navigation solves many problems, it adds a new accessibility problem. Left-handed and right-handed people should use the application. To cope with this situation we apply Right-Left handed users, design pattern. This pattern proposes control keys switching and screen mirroring to solve this problem.

To improve user orientation and localization, we applied Signs and Door at back design patterns.

A space transition happens when a user moves virtually and physically from one space to another; for instance from a room to another. As room shapes may vary, the Vertical-Horizontal Layout pattern is applied. As consequence we applied Layout Transition pattern,

too. When text documents are reached, Zoom pattern proposes to use left and right cursor keys to change font size (bigger and smaller, respectively) and up and down cursors to scroll text.

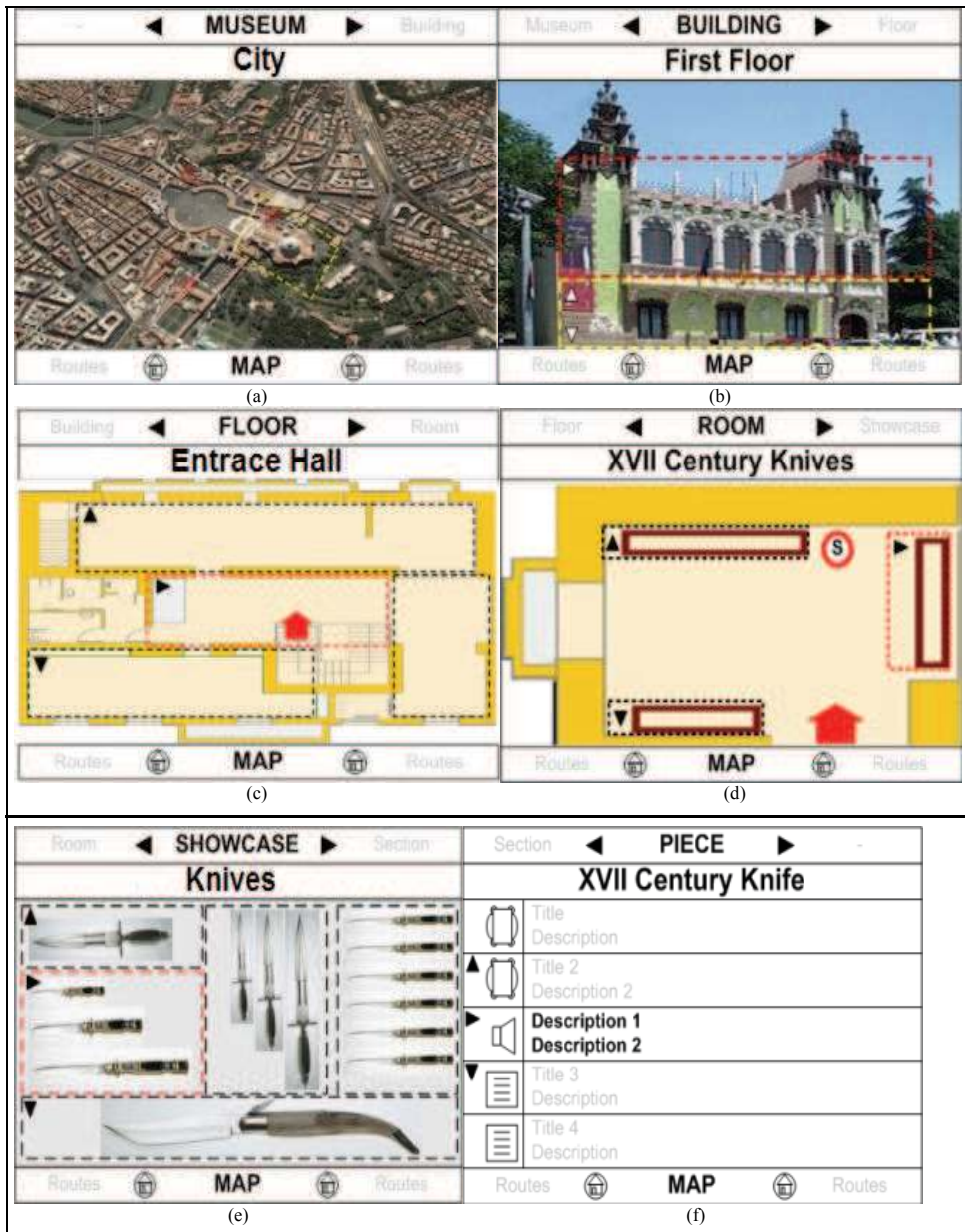

Fig. 14. Prototype UI.

8.3 The Evaluation

In this section we describe the satisfaction evaluation of the PDA client in both systems. The evaluations were based on a satisfaction questionnaire (Table. 1) that was prepared according to the CIF (Common Industry Format for Usability Reports) standard defined by the ISO/IEC DTR 9126-4.

People were queried about the system and were asked to express their feelings about MCA application. To get general impression about user satisfaction of MCA application a questionnaire was prepared according to the standard. Details and results of the study were published on (Tesoriero et al., 2007).

N°	Question	Level of Satisfaction					
		1	2	3	4	5	6
1	Do you like application design?						
2	Do you like application appearance?						
3	Do you feel graphics have good quality?						
4	Is it easy to learn this application?						
5	Did you get a good feeling about using the application?						
6	Was it difficult to choose the language?						
7	Is it easy to choose a room?						
8	Is it easy to get a showcase?						
9	Is it easy to find a piece?						
10	What do you think about usability?						

Table 1. Satisfaction questionnaire

The questionnaire is composed by ten multiple choice questions. Each question has six possible answers according to the users' level of satisfaction. The least satisfying answer scores 1 while the most satisfying scores 6. The experiment embraced three aspects of the application covered by this questionnaire. The first aspect is about graphic design and visual impact and it is covered by questions 1, 2 and 3. The second aspect is about application general usability and it is covered by questions 4, 5 and 10. Finally, the third one is about application concrete functionality (i.e. finding a showcase) and it is covered by questions 6, 7, 8 and 9. To measure users' experience satisfaction for a Question q the following formula is applied:

$$S_q = \sum_{l=1}^L \frac{l}{L} \cdot \frac{x_l}{N} \quad (1)$$

Where (S_q) is the satisfaction level of question q , (L) is the amount of possible answers (in this case 6), (x_l) is the amount of people that answered l in question q and (N) is the amount of people that filled the questionnaire.

The result of applying formula (1) is a value between $1/6$ and 1, the greater the better. Although the satisfaction evaluation embraces three aspects due to the fact we have developed a prototype using design patterns we will focus on the last two aspects of the application general usability and concrete functionality because appearance details were left to a later stage of development. System evaluation results are exposed in Fig. 15.

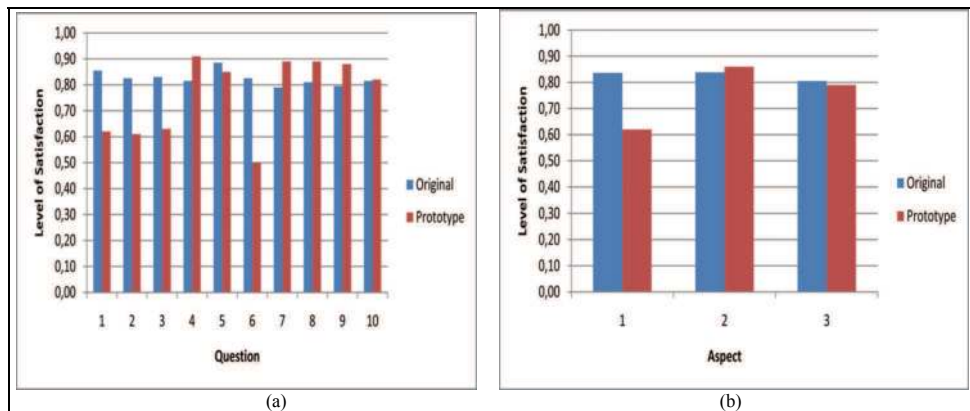

Fig. 15. Results of satisfaction evaluation

Comparing results we found that application design, graphic quality, application appearance and language selection are below of the mean. The main reason of UI appearance targeted a low score is the fact that it is just a preliminary prototype and we did not care about graphical design at this stage because the application supports skins and it should be customized according the specific situation, we focused our efforts on usability issues leaving details for later. Language selection was finding, because we thought that people only think about changing language in the beginning only, but experience demonstrated that it is not true.

Other issues are above 82% of satisfaction and it is remarkable because it is a good mark in general, taking into account that the scale starts at 17.67% and 83.33% represent a level of satisfaction of 5 point on 6. If we see Fig. 15b where we based our analysis on three aspects defined before: graphic design and visual impact, general usability, concrete functionality, we found that first aspect was discussed on previous analysis, so we will center the discussion on aspect 2 and 3. On Aspect 2, we can deduce that people are not aware or underestimate general usability issues because scoring in question 10 (usability in general) is 82.14% and it is the lower value of usability questions, because the other two questions averages 87.5%. We think that the poor performance on Aspect 1 affected this item, although indirectly. As we discussed before, on Aspect 3 language selection had affected the result on 9.72% and concrete functionality would have scored almost 89%.

9. Conclusions and Future Work

As new types of applications emerge, technology advances and a new set of applications (m-space applications) arises. These applications have characteristics and constraints related to

the physical space that define them. Some problems associated to these issues should be coped. To solve these problems, we have proposed an HCI design pattern language. These patterns have been grouped in categories that solve related problems providing a useful way to identify them. As we can see from the evaluation results we can deduce that usability is improved applying these patterns. We want to remark also that the catalogue could be extended with new patterns covering new needs, making it as open and flexible as possible. Our work in progress is currently focused on patterns evaluation. Usability evaluation tests are being designed to measure usability before and after the application of these patterns. We are also thinking about performing these tests inside and outside an HCI Lab and compare these measurements.

From our perspective, we think that m-space applications are not mature enough and more research is needed to achieve natural interaction and better user experience. So we propose some future work on this field to improve HCI on this environment. In order to improve interaction on m-space applications, sensors could be also used to suppress manual navigation with cursor keys. To provide this functionality, there are many technologies currently available (RFID, Barcodes, IRDA, etc) that could be used to provide location aware applications (Tesoriero et al, 2008).

8. References

- Alexander, C.; Ishikawa, S.; Silverstein, M.; Jacobson, M.; Fiksdahl-King, I. & Shlomo A. (1977). *A Pattern Language: Towns, Buildings, Construction*. New York: Oxford University.
- Barber, C.; Bristow, H.; Cheng, S.; Hedley, A.; Kuriyama, Y.; Lien, M.; Pollard, J. & Sorrell, P. (2001). Augmenting Museums and Art Galleries, *Proceedings of Human-Computer Interaction INTERACT '01. The International Federation for Information Processing*, pp. 439-447, ISBN: 978-1-58603-188-6, Tokyo, Japan, July 2007, IOSPress, Amsterdam, The Netherlands.
- Bristow, H. W.; Baber, C.; Cross, J.; Woolley, S. & Jones, M. (2002). Minimal Interaction for Mobile Tourism Computers. *The Workshop "Mobile Tourism Support" at MobileHCI 2002*. <http://www.eee.bham.ac.uk/pcg/docs/Mobiletourismv4.1.pdf>.
- Ciavarella, C. & Paternò, F. (2004). The design of a handheld, location-aware guide for indoor environments. *Personal and Ubiquitous Computing*, Vol 8, No 2, April 2004, 82-91, Springer Verlag, London, England. ISSN: 1617-4909.
- Borchers J. (2001). *A Pattern Approach to Interaction Design*, John Wiley & Sons, May, 2001. ISBN 0471498289
- Dolgos, C. (1996). *Visiting the Virtual Museum: The World Wide Web and its Impact on Museum Education*. Thesis (M.S. Ed.). Bank Street College of Education, New York.
- Elliot, G. & Phillips, N. (2004). *Mobile Commerce and Wireless Computing Systems*. Pearson Education, ISBN 0201752409. New York.
- Falk, J. H. & Dierking, L. D. (1992). *The Museum Experience*. Whalesback Books. Washington.
- Gallud, J. A.; Penichet, V. M. R.; Argandoña, L.; González, P. & García J. A. (2005). Digital Museums: a multi-technological approach. *Proceedings of HCI-International Conference 2005*. ISBN 0-8058-5807-5, Las Vegas (USA), 2005, Lawrence Erlbaum Associates

- Gamma E.; Helm R.; Johnson R. & Vlissides J. (1995). *Design Patterns: Abstraction and Reuse in Object-Oriented Designs*, Addison-Wesley Professional, ISBN 0201633612.
- Gary, S. & Simon, S. Y.. Shim (2002). A Service Management Framework for M-Commerce Applications. *Mobile Networks and Applications*, Vol 7, 2002, 199–212. ISSN: 1383-469X.
- Georgiev T.; Georgieva E. & Smrikarov A. (2004). M-Learning - a New Stage of E-Learning. *Proceedings of International Conference on Computer Systems and Technologies (CompSys-Tech'04)*.
- Jackson, R.; Bazley, M.; Patten, D. & King, M. (1998). Using the Web to Change the Relation Between a Museum and its Users. *Proceedings of the Second International Conference Museums and the Web*. Ed. David Bearman and Jennifer Trant: Museums and the Web 1998: Selected Papers published on CD-ROM, Toronto, Canada, April, 1998. Pittsburgh, PA: Archives & Museum Informatics.
- Léger, P. M.; Cassivi L. & Fosso Wamba S. (2004). Determinants of the Adoption of Customer-Oriented Mobile Commerce Initiatives, International Association of Management of Technology. *Proceedings of IAMOT, Virtual Organizations and Partnerships / E-Commerce Track*, Washington D.C.
- McKenzie, J. (1998). Building Virtual Museums. From Now On. *The Educational Technology Journal*. URL = <http://www.fromnowon.org/museum/museum.html>. Last visited 09/14/1998.
- Norman, D. A. (1988). *The design of everyday things*, Basic Books. ISBN 0-262-64037-6
- Roth, J. (2002). Patterns of Mobile Interaction. *Journal Personal and Ubiquitous Computing*, Vol 6, No 4, September, 2002, 282-289, ISSN 1617-4909.
- Schweibenz W. (1999). The Learning Museum: How Museums use information Technology to present value added Collection Information for Lifelong Learning. *Proceedings of the 7th International BOBCATSSS Symposium Learning Society – Learning Organisation – Lifelong Learning*, Bratislava, Slovak Republic, January, 1999, Sandra Beheim, Stephan Cradock, Eva Dächert, Sonja Pfürr.
- Tesoriero, R.; Lozano, M. D.; Gallud, J. A. & Penichet, V. M. R. (2007). Evaluating the Users' Experience of a PDA-Based Software Applied in Art Museums. *Proceedings of 3rd International Conference on Web Information Systems and Technologies (WebIST07)*, pp. 351-358, ISBN 9789728865788, Barcelona, Spain, March, 2007, INSTICC Press.
- Tesoriero, R.; Montero, F.; Lozano, M. D. & Gallud, J. A. (2007b): HCI Design Patterns for PDA Running Space Structured Applications. *Proceedings of 12th International Conference on Human-Computer Interaction (HCI 2007)*, pp. 1206-1215, ISBN 978-3-540-73104-7. Vol 4550, Beijing, China, July, 2007. Springer LNCS, Berlin, Heidelberg, Germany (2007)
- Tesoriero, R.; Lozano, M. D.; Gallud, J. A.; Montero, F. (2007c): Applying HCI Design Patterns to PDA Applications on Art Museums. *Proceedings of 3rd International Conference on Web Information Systems and Technologies (WebIST07)*, pp. 490-496, ISBN 9789728865771, Barcelona, Spain, March, 2007, INSTICC Press.
- Tesoriero, R.; Gallud, J. A.; Lozano, M. D. & Penichet, V. M. R. (2008): A Location-Aware System Using RFID and Mobile Devices for Art Museums. *Proceedings of The Fourth International Conference on Autonomic and Autonomous Systems (IARIA-ICAS 2008)*, ISBN 0-7695-3093-1, Gosier, Guadeloupe, March, 2008, IEEE Computer Society Press.

- Tidwell, J., (1999). *Common Ground: A Pattern Language for Human-Computer Interface Design*. URL http://www.mit.edu/~jtidwell/common_ground_onefile.html.
- Tidwell, J. (2005). *Designing Interfaces: Patterns for Effective Interaction Design*, O'Reilly, ISBN 0596008031
- van Welie, M. & Trætteberg, H. (2000). Interaction Patterns in User Interfaces, *Proceedings 7th Pattern Languages of Programs Conference (PLoP 2000)*, Allerton Park, Monticello, Illinois, USA.
- van Welie, M.; van der Veer, G. C. & Eliëns, A. (1999). Breaking down Usability. *Proceedings of Interact '99*, Edinburgh, Scotland
- W3C Working Group. Common Sense Suggestions for Developing Multimodal User Interfaces 2006. URL <http://www.w3.org/TR/mmi-suggestions/>.



Human Computer Interaction: New Developments

Edited by Kikuo Asai

ISBN 978-953-7619-14-5

Hard cover, 382 pages

Publisher InTech

Published online 01, October, 2008

Published in print edition October, 2008

The book consists of 20 chapters, each addressing a certain aspect of human-computer interaction. Each chapter gives the reader background information on a subject and proposes an original solution. This should serve as a valuable tool for professionals in this interdisciplinary field. Hopefully, readers will contribute their own discoveries and improvements, innovative ideas and concepts, as well as novel applications and business models related to the field of human-computer interaction. It is our wish that the reader consider not only what our authors have written and the experimentation they have described, but also the examples they have set.

How to reference

In order to correctly reference this scholarly work, feel free to copy and paste the following:

R. Tesoriero, J. A. Gallud, M. D. Lozano and V. M. R. Penichet (2008). HCI Design Patterns for Mobile Applications Applied to Cultural Environments, Human Computer Interaction: New Developments, Kikuo Asai (Ed.), ISBN: 978-953-7619-14-5, InTech, Available from:
http://www.intechopen.com/books/human_computer_interaction_new_developments/hci_design_patterns_for_mobile_applications_applied_to_cultural_environments

INTECH

open science | open minds

InTech Europe

University Campus STeP Ri
Slavka Krautzeka 83/A
51000 Rijeka, Croatia
Phone: +385 (51) 770 447
Fax: +385 (51) 686 166
www.intechopen.com

InTech China

Unit 405, Office Block, Hotel Equatorial Shanghai
No.65, Yan An Road (West), Shanghai, 200040, China
中国上海市延安西路65号上海国际贵都大饭店办公楼405单元
Phone: +86-21-62489820
Fax: +86-21-62489821

© 2008 The Author(s). Licensee IntechOpen. This chapter is distributed under the terms of the [Creative Commons Attribution-NonCommercial-ShareAlike-3.0 License](#), which permits use, distribution and reproduction for non-commercial purposes, provided the original is properly cited and derivative works building on this content are distributed under the same license.