

## Chapter

# Application of Solar Energy in Medical Instruments (Microscope)

*Badria Ibrahim Eisa Idris, Ahmed Mohamed, Ayah Salah, Osman Abdalrahman Almahdi Alamin, Fatehia Garma and Alnazier Osman*

## Abstract

Investments in solar PV capacities are now rapidly growing in both grid connected and off grid mode. Solar generation has been a reliable source for supplying electricity in regions without access to the grid for long. Development of renewable energy sources, therefore, has a vast potential in Sudan. Solar energy is a radiant energy which produces by the sun as result of nuclear fusion reaction. Medical services cannot be reached to people in rural areas and war's zones which remotely isolated because of poor road links with the urban centers, and remoteness from the national electrical transmission grid. So, to make the medical services available, a PV encapsulation and manufacturing solar system is used to generate an electric supply which used to supply them, and the microscope's circuit is changed to achieve the required results.

**Keywords:** Solar energy, Renewable energy, PV system, Microscope

## 1. Introduction

Solar Energy is radiant energy produced in the sun as a result of nuclear fusion reactions. It is transmitted to the earth through space by electromagnetic radiation [1].

Global installed capacity for solar-powered electricity has seen an exponential growth, reaching around 227 GWe at the end of 2015. It produced 1% of all electricity used globally. Major solar installation has been in regions with relatively less solar resources (Europe and China) while potential in high resource regions (Africa and Middle East) remains untapped [2].

Residents of rural and remote communities continue to show poorer health outcomes than residents in metropolitan centers, while the health of Indigenous communities remains unacceptable. While residents face increasing difficulties in accessing appropriate care in situations where integration and continuity of care are woefully inadequate [3].

In today's climate of growing energy needs and increasing environmental concern, alternatives to the use of non-renewable and polluting fossil fuels have to be investigated, one such alternative is solar energy.

Using a solar energy to operate medical devices one of an important applications to an alternative energy. Development of renewable energy sources, therefore, has a vast potential in Sudan as it known because of great sun peak during the year, in Sudan medical services cannot be reached to people in rural areas and war's zones

which remotely isolated because of poor road links with the urban centers, and remoteness from the national electrical transmission grid. So, to make the medical services available, a PV encapsulation and manufacturing solar system is used to generate an electric supply which used in health centers.

Operating a microscope (60 watts) using a solar energy depends on: Time of sun peak in Sudan which is about 9 hours/day generate 6.3 KW, The time of turning on the device which is 6 hours/day and solar modules.

By two ways had been tested:

1. AC method: by converting the DC solar output into AC using an inverter at this process.
2. DC method: by modulating the microscope power supply from AC to DC by canceling the transformer with his protection circuit, and changing the AC 6 volt lamb into DC 12 volt lamb using a Zener diode 12 volt as a voltage regulator.

## **2. Theoretical backgrounds**

### **2.1 Background of the study**

Since 1960's the use of the energy becomes as a necessary part of life. The concept of solar cells takes a place on 1970 when researchers looking for another kind of energy sources which is clean and environment friendly. Many countries use this technology until this moment, but the solar cells produce low amount of energy that makes it use as narrow as seen. The researchers made many research on this field to increase the production of energy from the solar cells, one of these researches is to enhance the silicon capability by using the material science and technologies [4].

### **2.2 Renewable energy**

Renewable energy is energy which comes from natural resources, it flows involve natural phenomena such as sunlight, wind, tides, plant growth, and geothermal heat [4]. It provides 19% of electricity generation worldwide [5]. **Figure 1** shows the different type of renewable energy.

### **2.3 Solar energy**

Solar Energy is radiant light and heat from the sun that is harnessed using a range of ever-evolving technologies, It is an important source of renewable energy and its technologies.

Solar Radiation reaches the Earth's upper atmosphere at a rate of 1.37 kwatts per square meter (kW/m<sup>2</sup>) in Sudan [7].

Advantages of solar energy:

Here are the main advantages of solar energy [7]:

1. One of the cleanest forms of energy.
2. Harmonious with nature.
3. Safe to handle.
4. Easy to install, operate and maintain.

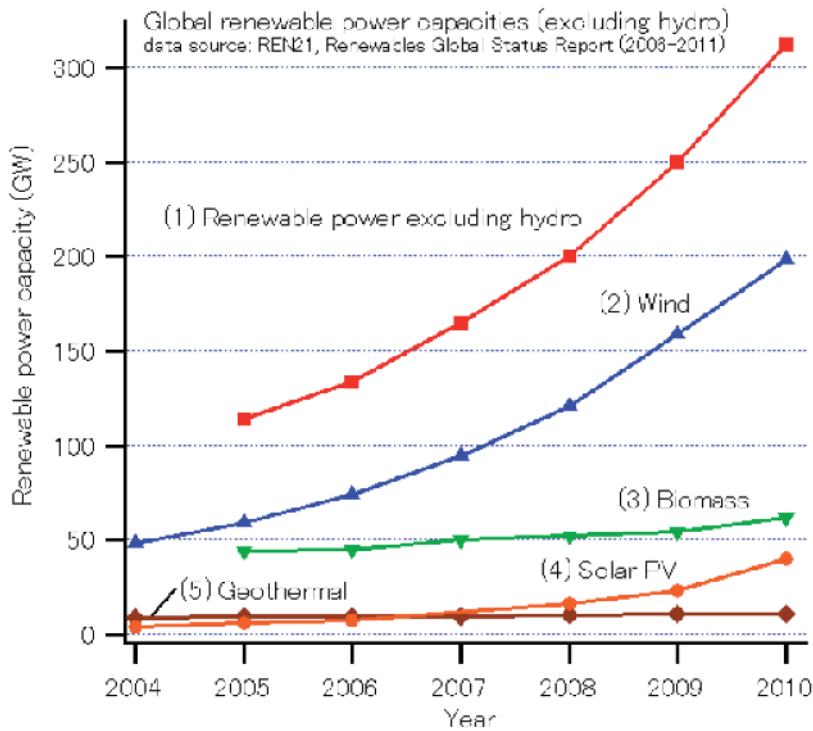

**Figure 1.**  
*Renewable energy progress [6].*

5. Long life. Solar panels can last up to 20 years or more.
6. Ideal for remote areas, where electricity is not reliable.

## 2.4 Photovoltaic cells (PV)

Solar cells (also called photovoltaic cells or photoelectric cells) are the most basic components of solar units that convert light energy into electricity. The cells are wired in series, sealed between sheets of glass or plastic, and supported inside a metal frame. These frames are called solar modules or panels [7].

The main parameters that characterize a PV panel are:

1. Short circuit current ( $I_{SC}$ ): the maximum current provided by the panel when the connectors are short circuited.
2. Open circuit voltage ( $V_{OC}$ ): the maximum voltage that the panel provides when the terminals are not connected to any load (an open circuit).
3. Maximum power point ( $P_{max}$ ): the point where the power supplied by the panel is at maximum, where  $P_{max} = I_{max} \cdot V_{max}$ .
4. Fill factor (FF): the relation between the maximum power that the panel can actually provide and the product  $I_{SC} \cdot V_{OC}$ .
5. Efficiency ( $\eta$ ): the ratio between the maximum electrical power that the panel can give to the load and the power of the solar radiation (PL) incident on the panel [8].

Types:

There are two primary types of PV technologies available commercially are crystalline silicon and thin film. **Table 1** shows two different type of solar module.

## 2.5 Typical solar system components

### 2.5.1 PV module

A number of solar cells electrically connected to each other and mounted in a support structure or frame is called a photovoltaic module.

### 2.5.2 The battery

Battery serves two important purposes in a photovoltaic system: to provide electrical energy to the system when energy is not supplied by the array of solar panels, and to store excess energy generated by the panels whenever that energy exceeds the load [8].

### 2.5.3 The regulator

It used to ensure that the battery is working in appropriate conditions, and to avoid overcharging or over discharging the battery, both of which are very detrimental to the life of the battery [8].

### 2.5.4 Convertor

There are two main types of convertor's:

	Crystalline silicon		Thin film
	Monocrystalline silicon (c-Si):	Multicrystalline silicon (mc-Si):	Amorphous silicon
Efficiency Cell	20–30%	18–22%	13.5%
Production cell	12–15%	11–14%	2–6%
Advantage	<ul style="list-style-type: none"> <li>• Well established and test technology.</li> <li>• Stable.</li> <li>• Can be made in square cells better power density.</li> </ul>	<ul style="list-style-type: none"> <li>• Well established and tested technology</li> <li>• Stable efficiency</li> <li>• less expensive than single crystal silicon.</li> <li>• Square cells allow efficient packing density.</li> </ul>	<ul style="list-style-type: none"> <li>• Low material use.</li> <li>• Preparation of thin films is possible.</li> <li>• Higher Absorption properties.</li> <li>• Potential for low cost.</li> <li>• Less affected by shading.</li> </ul>
Disadvantages	<ul style="list-style-type: none"> <li>• Uses expensive material.</li> <li>• Waste in slicing wafers.</li> </ul>	<ul style="list-style-type: none"> <li>• Uses expensive material.</li> <li>• Waste in slicing wafers.</li> </ul>	<ul style="list-style-type: none"> <li>• Pronounced degradation in power output.</li> <li>• Low efficiency.</li> <li>• It is difficult to maintain uniformity of the film over large areas.</li> </ul>

**Table 1.**  
Shows types of solar modules [9].

#### 2.5.4.1 DC/DC converters

DC/DC converters transform a continuous voltage to another continuous voltage of a different value.

#### 2.5.4.2 DC/AC converter (or inverter)

Inverters are used when your equipment requires AC power. Inverters chop and invert the DC current to generate a square wave that is later filtered to approximate a sine wave and eliminate undesired harmonics. Be aware that not all the equipment will accept a modified sine wave as voltage input [10].

#### 2.5.5 Equipment or load

The load (microscope) is the equipment that consumes the power generated by your energy system. The load may include medical equipments, routers, workstations, lamps, TV sets, etc. In this type of system it is absolutely necessary to use efficient and low power equipment to avoid wasting energy. It should be obvious that as power requirements increase, the expense of the photovoltaic system also increases.

## 2.6 Microscope

Is an instrument used to see objects that are too small to be seen by the naked eye [11], optical instrument that have a magnifying lens for inspecting objects which are too small to be seen by human's eyes. Microscopes are used to observe the shape of bacteria, fungi, parasites and host cells in various stained and unstained preparations [12].

#### 2.6.1 Types of microscope

1. Light microscope.
2. A compound light microscope.
3. Electron microscope.

#### 2.6.2 Parts of the microscope

The main parts of microscope will show bellow in **Figure 2**.

#### 2.6.3 Functioning of the microscope

There are three main optical pieces in the compound light microscope. All three are essential for a sharp and clear image. These are:

##### 1. Condenser

It illuminates the object by converging a parallel beam of light on it from a built-in or natural source.

##### 2. Objectives

It forms a magnified inverted (upside down) image of the object.

### 3. Eye-pieces

It magnifies the image formed by the objective. This image is formed below the plane of the slide. **Figure 3** shows an electrical circuit of microscope:

### 2.7 Collecting all the components together

As seen in **Figure 4** all the component of photovoltaic were collecting together, solar panels generate power when solar energy is available, the regulator to prevent batteries' damage, the battery for storing collected energy to be used later,

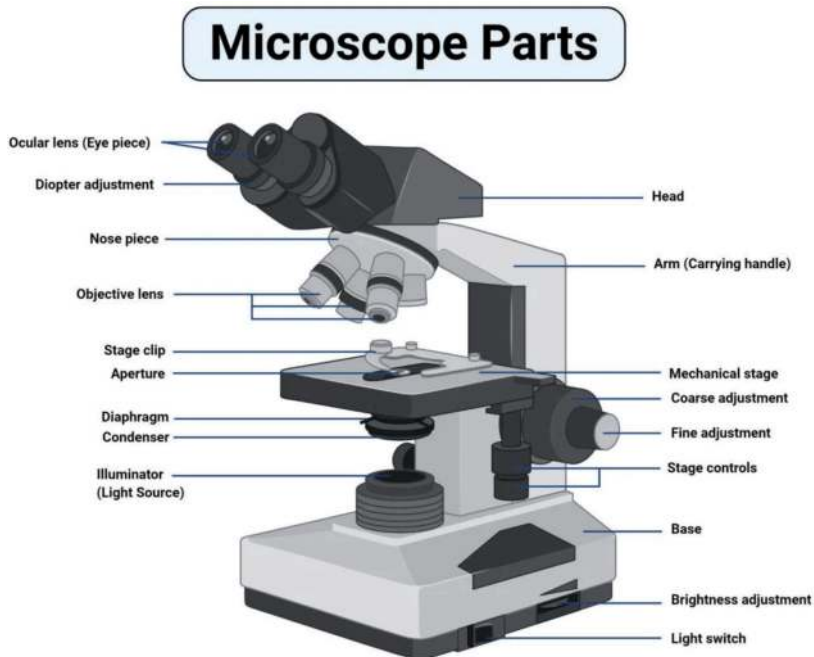

**Figure 2.**  
*Parts of microscope [13].*

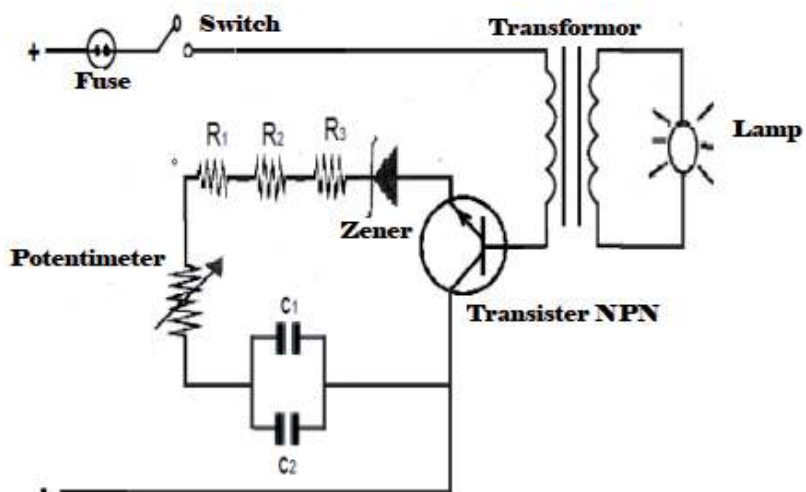

**Figure 3.**  
*Microscope' circuit diagram.*

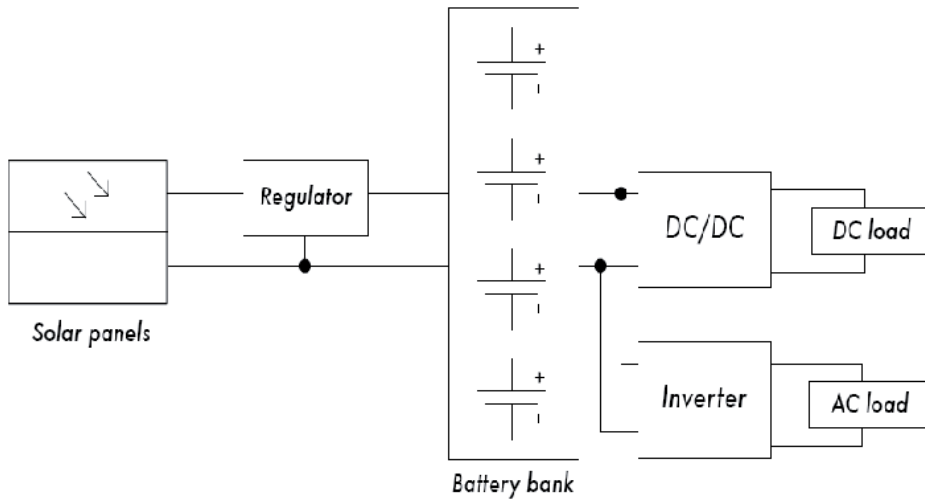

**Figure 4.**  
 A solar installation with DC and AC loads.

converters and inverters for adapting the stored energy, and finally, the load (microscope) consumes the stored energy to do work. When all of the components are in balance and are properly maintained, the system will support itself for years [9].

### 3. Research methodology

#### 3.1 Introduction

This chapter contains experimental procedure and measurement which has been recorded during the testing period medical devices operating solar (For example: microscope). In addition it presents operational problems.

#### 3.2 Design circuit

The circuit of the microscope was modulated because:

1. The device work with AC but solar cell generate DC.
2. To avoid the use of the inverter because it is expensive. Transformer has been canceled, two potentiometers were connected in series (one static and variable), adding Zener with a value of 12 volt (to maintain the value of effort fixed), it was used for halogen bulb 12v, switch and fuse. And finally connect all components of the circuit taking into account the polarity. **Figure 5** shows that.

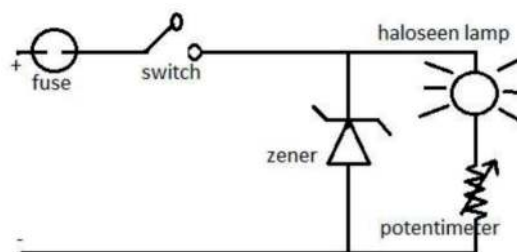

**Figure 5.**  
 Modulated circuit of microscope.

Fuse 1.6 A, Switch (on/off), Zener 12 voltage, DC haloseen lamp 12 v  
Potentiometer 1M $\Omega$ . A new microscope circuit was designed on experimental board and expert in university lab using a power supply unit, it was adjusted on DC current 3A and 12 V, the board connected to the supply and turned on the lamp was illuminated.

### **3.3 Sizing photovoltaic calculations**

System sizing calculations are important, because unless the system components are balanced, energy (and ultimately, money) is wasted. A microscope needs 20w income to run any device operates on-off actuation 6 hours.

#### *3.3.1 Calculate the number of module*

To calculate the number of panels required to cover a given load, you just need to know the current and voltage at the point of maximum power:  $I_{pmax}$  and  $V_{pmax}$  ( $I_{pmax}$  and  $V_{pmax}$  are provided by the manufacturer).

#### *3.3.2 About The Efficiency*

1. Battery efficiency = 0.90
2. Charge controller efficiency = 0.90
3. Inverter efficiency = 0.85
4. Conversion factor for DC load = 0.81
5. Conversion factor for AC load = 0.72

#### *3.3.3 Load calculations*

The Power = voltage\*current

$$P = 6 \times 3.3 = 20 \text{ W}$$

Total power (Energy consumption) = the power\*number of devices

$$\text{Total power} = 20 \text{ W} \times 1 = 20 \text{ W}$$

Power (watts/hour) = total power\*required time loads

$$P (\text{W/h}) = 20 \times 6 = 120 \text{ W/h}$$

The required power of cells = energy consumption/system factor

$$\text{The required power of cells} = 120 \text{ W}/0.81 = 148 \text{ Wh}$$

Battery capacity = the required power/system voltage

$$\text{Battery capacity} = 148/12 = 12.31\text{AH}$$

The cell Production = 18

The No. of Modules = battery capacity/cell production

$$\text{The No. of Modules} = 12.31/18 = 0.68 \approx 1\text{modules}$$

#### *3.3.4 Battery calculations*

The required battery capacity = battery capacity/depth of discharge

$$\text{The required battery capacity} = 12.31/0.4 = 30$$

The available capacity 70AH



The No. of batteries = capacity batteries/the available capacity  
 Number of batteries =  $30.78 / 70 = 0.44 \approx 1$  battery

### 3.3.5 Regulator calculations

The charge controller load current = maximum current cell\*the number of modulus

Isc = 3.5A

Appropriate regulator =  $3.5 * 1 = 3.5A$

### 3.3.6 Inverter calculation

Inverter = overall capacity/inverter efficiency

Inverter = 21.05 Watts

### 3.3.7 System components

Solar cell 50 W

Battery 60 Ah

Regulator 20A

Inverter 21.05 W

## 3.4 Testing instruments

### 3.4.1 Load

Microscope device is selected because it is a simple device does not consume high power compared with other devices, Electrical specifications for the Microscope:

In the case (AC):

Input 220 V; output 6 V, 3.3A, 20.4 W.

In the case (DC):

Input 12 V, 1.6 A, 19.2 W.

### 3.4.2 PV module

The **Table 2** shows specifications of solar panel.

### 3.4.3 Electrical parameters of a Solar cell (by the manufacturer)

Maximum power:  $50 \pm 3\%$  Wp

Short circuit current: 3.09A

Open circuit voltage: 21.6 V

Max. Power current: 2.89A

Max. Power voltage: 17.3 V

Standard test condition at: 1,000 w/m<sup>2</sup> solar irradiance. Cell temperature 25°C, AM 1.5.

Type of module Wp	Isc	Ipm
50	3.01	2.76

**Table 2.**  
*Solar modules electrical specifications.*

### 3.4.4 Inverter

Specification:

1. DC input 10-15 V
2. AC output 220-240 V, 50 Hz/60 Hz.
3. Constant output power 300Watts.

### 3.5 Experiments

At the first experiment was wired between the charge controller and the load but it was not work because output current from it was less than 3A to operate the load.

#### 3.5.1 DC way

After modifying the load it can work immediately with DC current. This solar photovoltaic lighting system consists of a 20Watt single crystalline module, a self-contained photovoltaic controller with (regulator), a sealed lead-acid battery and a single 100 Watt fluorescent light. The system will provide daily lighting throughout the year. **Figure 6** shows block diagram of DC way.

#### 3.5.2 Inverter way

The four primary components for producing electricity using solar power, which provides common 220volt AC power for daily use, are: Solar panels, charge controller, battery and inverter. Solar panels charge the battery, and the charge regulator as it will be shown in **Figure 7** ensures proper charging of the battery. The battery provides DC voltage to the inverter, and the inverter converts the DC voltage to normal AC voltage.



**Figure 6.**  
*Block diagram of solar system without inverter.*

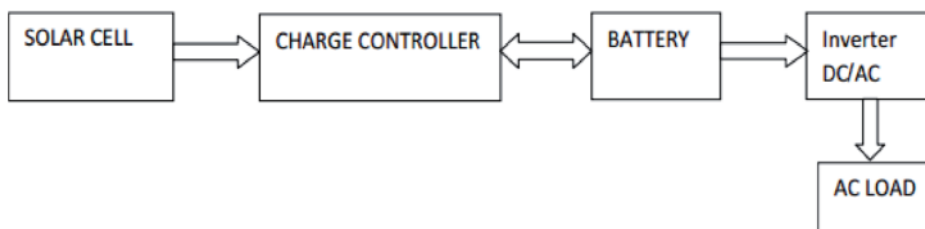

**Figure 7.**  
*Block diagram of solar system with inverter.*

#### 4. Results

The design of modulated circuit shown below in **Figure 8** discuss that solar energy (direct current) can be used to turn on the load for continues six hours to solve problem as it mentioned earlier.

##### 4.1 This device was tested with solar (AC way)

The load can work in another way .by converting the output direct current from the batteries to AC current using a DC/AC inverter .this current can operate immediately without any modulating in circuit as shows bellow in **Figure 9**.



**Figure 8.**  
*Microscope's modulated circuit with direct current.*



**Figure 9.**  
*AC way.*

### 4.2 Solar was tested with solar (DC way)

After the circuit was modulated in order to work with solar current, it should be tested using solar to perform project, **Figure 10** come next shows the result of problem which mentioned previously.

The circuit was operated with DC of solar, finally after that the sensitivity of this light should be measure to avoid eyes' damage.

### 4.3 Photo sensitivity of light

Photo sensitivity (PS) is ratio of radiant energy expressed in watt(W) incident on the device, to the resulting photo current expressed in amperes(A) it may be represented as either an absolute sensitivity(A/W) or as relative sensitivity normalized, usually expressed in percentage (%), PS should be more than 5%, **Table 3** shows the PS of light from electrical power and from solar power, PS was calculated for both, the PS of them in acceptance percentage.

When solar power was used; PS of it = 8.3% it's > 5%, so, it is in range of acceptance and then the doctors could see with this light without any effective to their eyes.



**Figure 10.**  
*DC way.*

	Solar energy		Electrical supply	
	DC	AC	DC	AC
Ampere	1.6	3.3	1.6	3.4
Voltage	12	6	11.9	5.8
Photosensitivity	0.083	0.167	0.084	0.172

**Table 3.**  
*PS of electrical and solar energy.*

Tool	The cost(SDG)
Panels (50 W)	600
Charge control (10A)	300
Batteries (12 V,65 Ah)	750
Inverter (300 W)	450
Wiring	50
Σequipment	2150

**Table 4.**  
*The cost of solar system.*

#### 4.4 Economic results

The cost of inverter way is 2150 SD pounds and it can work for 25 years without any additional cost. But DC way is cheaper and cost 1700 SD pounds without any additional cost. **Table 4** shows calculated the cost of solar system.

The annual cost of the electric power grid is calculated for a period of 25 years by Sudanese pound (SDP).

The cost of electricity power =

$$\text{Total power (Wh)} * 0.76 \text{ SDP/kW} * 365.25 \text{ day} * 25 \text{ years} = 833 \text{ SDP}$$

The electricity power is the cheaper than PV system; but the solar energy can be used in rural areas where there is no electricity power and offer medical services to fulfill the project's objective.

#### 5. Recommendations

1. Solar PV system can be alternative technology for remote rural areas where grid electric power **is not** available. Grid electric power is more cost effective power supply than Solar system. But this system can be alternative for some of medical devises.
2. Then and finally as if the microscope was modulated and operated with solar energy, we recommend that to operate small healthcare units in rural areas.

#### 6. Conclusions

The microscope illuminated by solar cell. Some medical devices operated by using solar energy, which this energy produces a DC current. These devices modulated by canceling step down transformer and rectifier, and offered appropriate DC current by sizing photovoltaic cell and a charging battery or used inverter to convert DC current to AC current. Solar cell is more expensive than electricity power, but it can use in areas where there are no electricity power.

In comparison to other energy sources such as coal, natural gas, nuclear, wind, and hydro-electric, solar energy is one of the least cost effective. For the most part, the exorbitant cost of solar energy is due to the high cost of manufacturing high quality solar panel material that has high energy conversion efficiency. Today, most cheaply made solar cells have an energy efficiency of about 14% while the higher quality materials achieve efficiencies of about 20–25% solar energy is still relatively expensive to a consumer.

## **Acknowledgements**

At the beginning we would like to thank our project supervisor, Dr. Alnazeir Osman Hamza for the valuable guidance and advices, also the ministry of science and technology Renewable Energy Institute (the Photovoltaic Encapsulation & Manufacturing Unit (Khartoum-south)) for providing us with a good environment and facilities to complete this project.

Also we will take this opportunity to thank Dr. Mohamed Altaib Alfadni the Executive Manager of Sharg alneel specialized hospital & Dr. Alfatih Abdelgader Alfadni who support us with a microscope device for testing.

## **Special declarations**

This project could not be completed without our parents' prayers so heartily thanking for them besides special thanking to Dr. Altahir Mohammed, Fatehia Garma.

## **Author details**

Badria Ibrahim Eisa Idris\*, Ahmed Mohamed, Ayah Salah, Osman Abdalrahman Almahdi Alamin, Fatehia Garma and Alnazier Osman Biomedical Engineering Department, Sudan University of Science and Technology, Khartoum, Sudan

\*Address all correspondence to: [bdriaibrahim@yahoo.com](mailto:bdriaibrahim@yahoo.com)

## **IntechOpen**

© 2021 The Author(s). Licensee IntechOpen. This chapter is distributed under the terms of the Creative Commons Attribution License (<http://creativecommons.org/licenses/by/3.0>), which permits unrestricted use, distribution, and reproduction in any medium, provided the original work is properly cited. 

## References

- [1] Definition of solar energy available from: [https://en.wikipedia.org/wiki/Solar\\_energy](https://en.wikipedia.org/wiki/Solar_energy) [Accessed: 2018-02-02]
- [2] World energy resources. 2016. Available from: [https://www.worldenergy.org/wpcontent/uploads/2017/03/WEResources\\_Solar\\_2016.pdf](https://www.worldenergy.org/wpcontent/uploads/2017/03/WEResources_Solar_2016.pdf) Accessed: 2018-02-02]
- [3] Nwafor S. Chimela\*, Ogbonna K. Nkem, Onyemuwa Nnaemeka, Olaniyi Abiodun <http://escijournals.net/index.php/IJAE/article/download/1923/916> [Accessed: 2018-02-07]
- [4] International Energy Agency, "renewable energy party", 2002.
- [5] Renewable Energy N21, "renewable 2010 global report", 2010.
- [6] renewable energy progress, available from: <http://upload.wikimedia.org/wikipedia/commons/thumb/6/65/GlobalREPowerCapacity-exHydro-Eng.png/290px-GlobalREPowerCapacity-exHydro-Eng.png> [accessed: 2018-02-07]
- [7] Tamil Nadu, "best practices in solar water pumping", Auroville's Centre for Scientific Research, India, 2002.
- [8] Rob Flickenger, Corinna Aichele, Carlo Fonda. Wireless Networking in the Developing World, Canada's International Development Research Centre, Canada, December 2007.
- [9] Green, Martin. A., Solar Cells: Operating Principles, Technology and System.
- [10] Jenny Nelson, "The Physics Of Solar Cells", Imperial College, UK, 2008.
- [11] definition of microscope [Internet]. Available from: <https://en.wikipedia.org/wiki/Microscope> [Accessed: 2018-02-01]
- [12] Mr K.K. Khanna, "THE MICROSCOPE", New Delhi, India, 1999.
- [13] parts of microscope Available from: <https://i.ytimg.com/vi/4rerHeaXSio/maxresdefault.jpg> Accessed: [2018-02-07].