Study of Novel Power Electronic Converters for Small Scale Wind Energy Conversion Systems

Mostafa Abarzadeh, Hossein Madadi Kojabadi and Liuchen Chang

Additional information is available at the end of the chapter

Abstract

This chapter proposes a study of novel power electronic converters for small scale wind energy conversion systems. In this chapter major topologies of power electronic converters that used in wind energy converter systems have been analysed. Various topologies of DC/AC single stage converters such as high boost Z-source inverters (ZSI) have been investigated. New proposed schemes for inverters such as multilevel and Z-source inverters have been studied in this proposed chapter. Multilevel converters are categorized into three major groups according to their topologies which are diode clamped multilevel converters (DCM), cascade multilevel converters (CMC) with multiple isolated dc voltage sources and flying capacitor based multilevel converters (FCMC). Z-source inverters are divided to ZSI, qZSI and trans-ZSI types. Trans-ZSI is mostly used for high step-up single stage conversions.

Keywords: Small scale wind energy conversion system, Multi-level converters, Z-source inverters, single stage converter

1. Introduction

Nowadays, renewable energy based systems have expeditious growth and enhanced technological development due to increasing worldwide electricity demand, environmental concerns and financial aspects. Due to environmental issues of using fossil fuel in power generation and increasing the demand of energy in world, renewable energy resources are much more considered to provide power energy demand. Renewable energy resources are environmentally friendly, socially beneficial, and economically competitive for many applications. Power electronic converters optimize renewable energy conversion system performance to operate on maximum power point. Furthermore, mentioned converters prepare suitable and standard

output power to supply loads. Thus power electronic converters enable efficient interconnection between renewable energy systems and loads [1, 2].

Wind turbines, photovoltaic systems and fuel cells are the main resources for renewable resource generation systems [1]. In comparison with other renewable energy resources, wind power is more appropriate for couple of applications with relatively lower expenditure [3, 4]. As long as most major companies are concentrating on implementation of large-scale wind turbines, small-scale wind turbines as small distributed power generators have significant development in order to utilize in micro grid systems, small faraway sites and small remote consumers [5]. Recently, with regards to increased global concern about negative effects of fossil-fuel based energy conversion systems, small-scale wind generation systems are much more noticed as alternative source for renewable energy conversion applications [6]. Small scale wind turbines (<100kW) can deliver power directly to homes, farms, schools, businesses, and industrial firms, compensating the need to purchase some portion of the host's electricity from the grid; such wind turbines can also provide power to off-grid sites [4-6]. A small-scale wind energy conversion system comprises a generator, a power electronic converter, and a control system. Among different types of small-size wind turbine, permanent magnet (PM) generator is widely used because of its high reliability, high efficiency and simple structure [1-3]. The power electronic converter in WECS has been used to provide suitable and applicable output power in order to supply stand-alone loads or to connect to power grid. Control systems are implemented to regulate the small-scale wind turbines shaft speed in order to operate at desired speed which leads to extract maximum power from wind [1-5].

For faraway communities and remote areas, it is applicable and considerable to use the stand-alone small-scale wind energy conversion system including the battery bank to provide reliable and stable power supply system for these areas [2, 7-10]. For the stand-alone wind energy conversion system, battery storage system acts as load to WECS system. Since the voltage remains almost constant, but the current flows through it can be varied, the battery can be also considered as a load with a various resistance. The battery can absorb any level of power as long as the charging current does not exceed its limitation. [2, 11, 12].

There is increasing demand for a grid connected small wind generating system (without battery storage systems) in order to provide renewable energy sources in distributed power systems. Small-scale WECS are exploited as undeniable parts of micro grids to provide distributed power resources. In this case the generated power from the wind generator is supplied to the utility grid. The AC grid can also be hybrid grid by using another power generation resources such as photovoltaic systems, fuel cells and diesel generators. Applicable grid connected inverter topology which exploits maximum power even at low wind speeds for small-scale WECS are considered to provide alternative power resources for AC grids and micro grids. Standard grid connected wind turbines use a charging controller to charge the batteries to provide reliable and stable power sources. The output grid connected inverter also is used to interface small-scale WECS with the power grid [5].

Authors proposed novel Z-source inverter that can produce very high output voltage gains. With the same duty ratio the proposed topology produces higher boost factor than diode assisted QZSI, alternate cascaded ZSI, and SL-ZSI. In other word the new topology requires

lower duty ratio for the same boosting voltage. Lower duty ratio will lead in higher modulation index and lower THD at output voltage. In renewable energy conversion systems both voltage buck and boost operating capabilities are needed, so before VSI an additional dc–dc converter is required, that this two stage configuration, increases the cost and reduces the efficiency of the system. By proposed ZSI, buck-boost capabilities is achieved with a single-stage power conversion. This unique feature also increases the immunity of the inverters to the EMI noises, which may cause uncontrolled shoot-zero (or open circuit) to destroy the conventional VSIs and CSIs, respectively. Meanwhile, in ZSI, both switches in a leg can be turned-on simultaneously to eliminate dead-time and to improve the quality of output waveform.

This chapter presents novel power electronic converters for small scale wind energy conversion systems for small-scale wind generators. Small-scale wind turbine consists of permanent magnet synchronous generator (PMSG), power electronic conversion system and load. Power electronic conversion system consists of AC/DC rectifier, DC/DC converter and DC/AC inverter. The chapter is organized as follows. In part 2, the small-scale wind turbine system is briefly described. In part 3, the conventional power electronic conversion system for wind turbine is proposed. Part 4 describes the multi-level converters and their applications in wind energy conversion systems (WECS). Finally, Z-source inverters are proposed in part 5.

2. Small-scale wind turbine system

The conventional small wind turbine comprises rotor, electric generator, control system and power conversion system. Rotor with a variable number of blades is utilized to convert the wind speed to mechanical rotational speed. Electric generator is also used to convert rotor mechanical rotation to electric power, control and power conversion systems are implemented to supply electricity into a battery bank or power grid [1, 13].

The electric generator is the major part of a small WECS which converts the mechanical rotation of wind rotor shaft to electrical power. There are two major types of utilized electrical generators for WECS which are self-excited induction generators (SEIG) and permanent magnet synchronous generators (PMSG). In order to provide applicable rotational speed to generators, gearbox must be utilized between wind turbine rotor and generator shaft. The gearbox converts the low rotational speed of the turbine rotor to the high rotational speed of generator shaft. Considering the fact that utilizing gearbox in WECS system leads to increase system overall weight, gearbox elimination can be achieved by utilizing the axial flux permanent magnet synchronous generators (AFPMSG) multiple-pole generator systems [1, 2, 13].

In order to energize the magnetic circuits in self-excited induction generators, parallel capacitors bank is equipped at the generator terminals to provide its necessary reactive power. Due to use the fixed capacitors bank, the reactive power and output terminal voltage might not be directly controlled. Consequently, terminal voltage fluctuation problem is emerged in self-excited induction generators [1, 2]. Therefore, the multiple-pole axial flux permanent magnet synchronous generators (AFPMSG) driven by a wind-turbine shaft without gearbox are much more considered. Small scale wind conversion system may be connected to loads or

power systems with full rated power electronic converters. The wind turbines with a full scale power converter between the generator and load will lead to improved performance. The gearbox driven self-excited induction generator based small-scale WECS is depicted in Fig. 1(a). The direct-couple axial flux permanent magnet synchronous generator based WECS is shown in Fig.1(b). The full range power conversion system is equipped between generator and load for providing standard output to load.

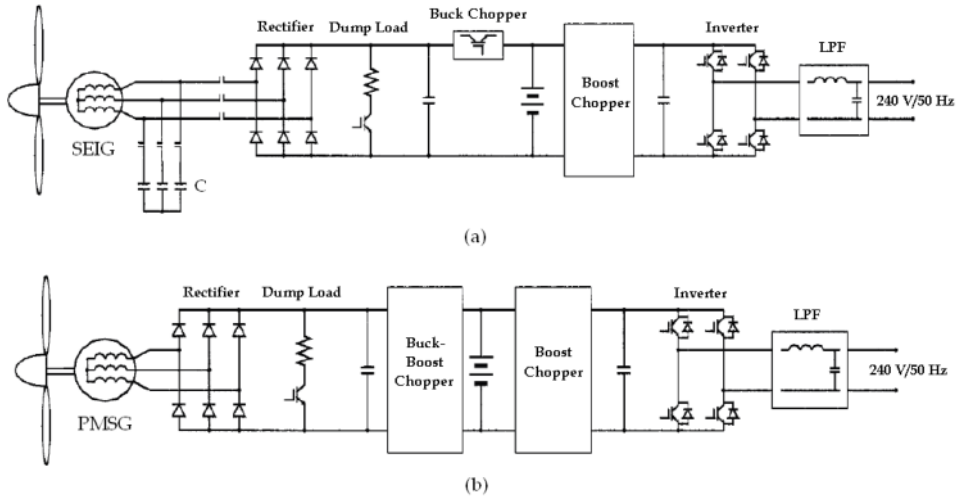

Figure 1. Small scale wind generation system. (a) self-excited induction generator with gearbox (b) direct coupled axial flux permanent magnet synchronous generator [1, 2]

The power protection during higher wind speeds in small scale wind turbines will be done by furling control [1, 2, 14]. Auto furling system is a passive mechanism utilized to protect the small-scale wind turbine in higher wind speeds [13]. There are several methods to mechanically control a wind turbine, like tilt up turbines, changing blade angle, and spoilers. Upwind rotor structure with passive yaw control by using tail vane is utilized in major part of small wind turbines. Auto furling system is operated by interaction between gravity and wind force. It operates based on interaction between wind turbine tail degree from wind turbine rotor and effective wind stream aerodynamic force. Eventually, during wind speeds above the nominal wind speed the tail vane starts to hinge which leads to decrease the wind turbine rotor speed. The over-speed protection is resulted during this condition. During higher wind speeds, generated output power of wind turbine could be bigger than the nominal power of wind generator which may damage the wind rotor or energy conversion unit. Hence, during high wind speeds, furling system deflects the turbine from the wind stream to protect whole system from probable damages. During furling conditions, there is a sharp decrease in the wind turbine output power curve [1, 13-16]. The typical furling system is depicted in Fig. 2.

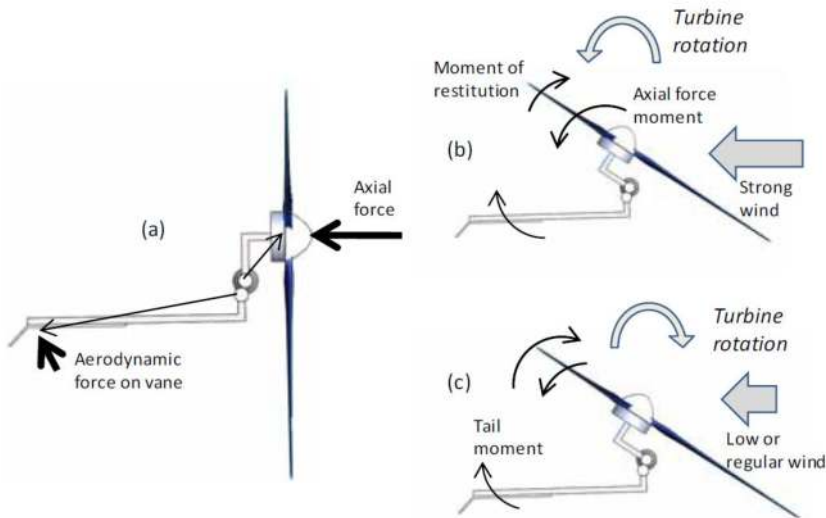

Figure 2. Overview of the operating principles of a furling system. (a) Aerodynamic forces. (b) Furling movement in strong winds. (c) Restitution of normal (aligned) operation upon reduction of the wind speed [13].

3. Conventional power electronic conversion system for wind turbine

In order to achieve maximum efficiency of wind energy conversion system the AC/DC/AC topology almost always used in small scale systems. This topology results maximum efficiency and full range working range which is applicable for WECS systems. To convert the variable AC voltage which is generated by AFPMSG, the diode rectifier should be used. Due to the fact that active power flows uni-directionally from the AFPMSG to power converter and load, only a simple diode rectifier can be applied to the generator side converter [5, 6]. In order to regulate and track maximum power point of wind turbine in various wind speeds, DC/DC converter is used [17]. In order to supply standard output AC loads, the inverter should be implemented at the WECS output.

3.1. AC/DC bridge rectifier

A three-phase bridge rectifier which gives six-pulse ripples on the output voltage is commonly used in small-scale WECS. The pair of diodes which are having the maximum amplitude of line-to-line voltage will conduct [18]. The typical three-phase bridge rectifier is depicted in Fig.3.

If we assume that V_m is the maximum value of the phase voltage, then the average output voltage can be considered as:

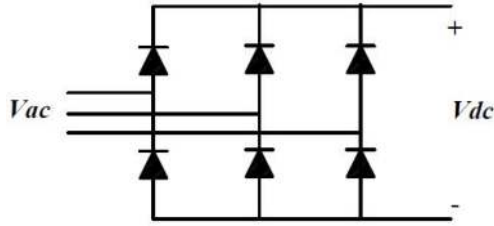

Figure 3. Three-phase bridge rectifier.

$$V_{dc} = \frac{2}{2\pi/6} \int_0^{\pi/6} \sqrt{3} V_m \cos \omega t d(\omega t) = \frac{3\sqrt{3}}{\pi} V_m = 1.654 V_m \quad (1)$$

3.2. DC/DC converters

Dc/dc converters are switch-mode converters which regulate variable voltage to a desired reference dc output voltage. The mostly used dc-dc converters which are defined as three terminal regulators are explained in this section [19]. They are characterized by the use of a choke rather than a transformer between the input and output lines, resulting in higher efficiencies and wider voltage ranges. There are four basic topologies of non-isolated dc to dc converters which can produce higher, lower or reversed polarity to the input.

3.2.1. Buck regulators

The buck regulator which is shown in Fig. 4 provides the output voltage lower than input dc voltage with the same polarity of input dc voltage [18]. The fundamental circuit of buck dc-dc converter is shown in Fig. 4.

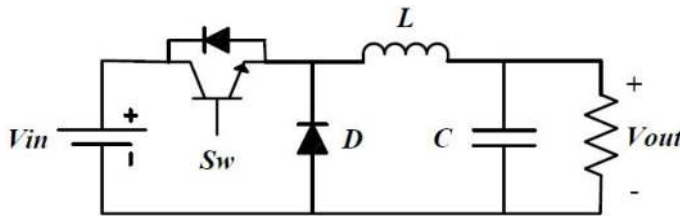

Figure 4. Basic circuit of buck dc-dc regulator.

The output voltage of buck converter is calculated by

$$V_{out} = k \times V_{in} \quad (2)$$

where V_{out} is output voltage, V_{in} is input voltage and k is duty cycle of switch. The output voltage can be controlled by varying the duty cycle. The buck converter is also known as a step-down converter, since its output must be less than the input voltage [18-21].

3.2.2. Boost regulators

The boost regulator which is depicted in Fig. 5 provides output voltage higher than input dc voltage with the same polarity of input dc voltage. Due to the existence of right-half-plane zero in boost converter's transfer function, it is hard to control it during high step up gain between output and input voltage [18-21]. The basic circuit of boost dc-dc converter is shown in Fig.5.

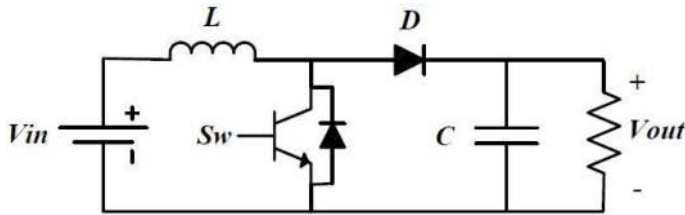

Figure 5. Basic circuit of boost dc-dc regulator.

The output voltage of boost converter is calculated by

$$V_{out} = \frac{1}{1-k} V_{in} \quad (3)$$

3.2.3. Buck-boost regulators

In order to achieve both step-up and step-down capability of dc-dc converter, buck-boost converter which is combination of buck and boost topologies is provided. The output voltage has opposite polarity to the input, but its value may be higher, equal, or lower than that of the input. This regulator also has right-half-plane zero in its transfer function which limits the step up gain of this converter [18-21]. The basic circuit of buck-boost dc-dc converter is shown in Fig.6.

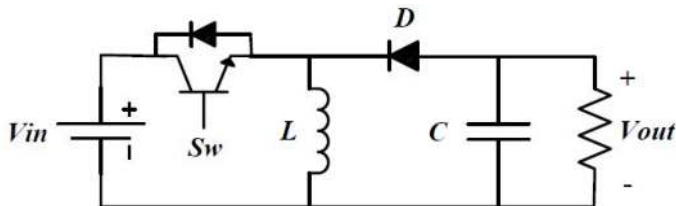

Figure 6. Basic circuit of buck-boost dc-dc regulator.

The output voltage of buck-boost converter is calculated by

$$V_{out} = -\frac{k}{1-k} V_{in} \quad (4)$$

3.2.4. Cuk regulators

Since buck-boost regulator has reverse polarity to the input dc voltage, so the new class of buck-boost regulator named cuk converter has been proposed. In this converter, the output voltage has the same polarity of input, but its value may be higher, equal, or lower than that of the input. This converter also has the right-half-plane zero in its transfer function [18-21]. The basic circuit of cuk dc-dc converter is shown in Fig.7.

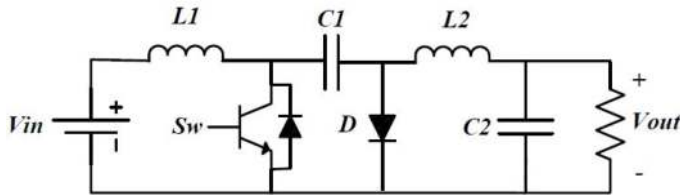

Figure 7. Basic circuit of cuk dc-dc regulator.

The output voltage of cuk converter is calculated by

$$V_{out} = \frac{k}{1-k} V_{in} \quad (5)$$

3.3. DC/AC inverters

DC-to-ac converters are defined as inverters which are used to convert input dc voltage to symmetrical output ac voltage in order to supply ac load or connect to grid. The inverter output voltage must satisfy specific standards which are defined as desired voltage amplitude, frequency and maximum allowable total harmonic distortion (THD) value. The ideal ac voltage waveforms should be sinusoidal. However, due to practical inverters work based on switching devices, output ac voltage of inverters is non-sinusoidal and contain certain harmonics [18, 22].

There are various switching methods which are applied to control the inverters. The pulse width modulation (PWM) control method is mostly used to provide suitable switching signals to control inverter switches. There are two major types of inverter which are classified as voltage source inverters (VSIs) and current source inverters (CSIs). The VSI inverters which are widely used in small scale WECS applications independently control the ac output voltage waveform. While, the CSI inverters independently control the ac output current waveform [18].

The single-phase VSI is shown in Fig. 8. It comprises four switches which are S_1 , S_2 , S_3 and S_4 . This type of inverter has three output voltage states which are V_d , 0 , $-V_d$. V_d is resulted at inverter output when S_1 and S_2 are on. When S_3 and S_4 are on, the inverter output voltage is $-V_d$. If all switches are off, the output voltage is 0. The root mean square (RMS) output voltage can be found from

$$V_O = \sqrt{\left(\frac{2}{T_0} \int_0^{T_0/2} V_d^2 dt \right)} = V_d \quad (6)$$

where V_O is rms value of output voltage. Output voltage can be represented in Fourier series. The rms value of fundamental component as

$$v_o = \sum_{n=1,3,\dots}^{\infty} \frac{4V_d}{n\pi} \sin n\omega t \rightarrow V_1 = \frac{4V_d}{\sqrt{2\pi}} = 0.90V_d \quad (7)$$

where v_o is output voltage and V_1 is rms value of fundamental component of v_o .

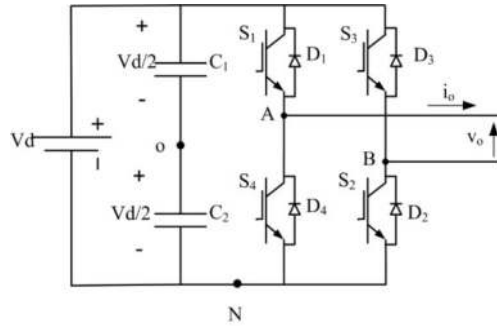

Figure 8. Single-phase full bridge inverter

4. Multi-level converters

The two-level VSI provides three output voltage levels which are 0 or $\pm V_d$. In order to improve the output voltage or current quality, it is required to apply higher switching frequency and enhanced PWM techniques which are restricted by switching device operating specifications and control systems implementation requirements [18].

The most remarkable superiority of multilevel converters in comparison with two-level inverters are synthesizing an output staircase voltage waveform which improves harmonic

content significantly, also reduces output $\frac{dv}{dt}$, electromagnetic interference and filter inductance, etc [18, 24-27]. By increasing the number of voltage levels, the output waveform will be a staircase form and this will lead in significant reduction of output voltage THD.

Multilevel converters divide to three major types as below:

- Diode-clamped multilevel (DCM) converters
- Cascaded multilevel (CM) converters [26].
- Flying capacitor multilevel (FCM) converters [24, 27].

4.1. Diode-clamped multilevel (DCM) converter

The n-level DCM converter which comprises $(n-1)$ capacitors, $2(n-1)$ switches and $(n-1)(n-2)$ clamping diodes provides n-levels output voltage. Considering dc bus voltage as E , the voltage across each capacitor is $\frac{E}{2}$, and each switch stress is restricted to one capacitor voltage level $\frac{E}{2}$ through clamping diodes.

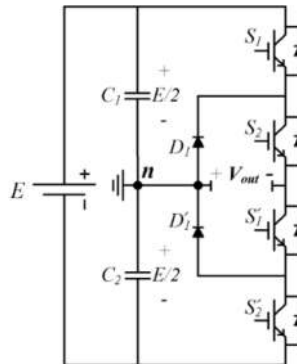

Figure 9. 3-level diode-clamped converter.

In order to provide staircase output voltage in DCM converter, if the S_1 and S_2 power switches are on, the staircase output voltage is $V_{out} = \frac{E}{2}$. When S_1' and S_2' power switches are on, the output voltage is $V_{out} = -\frac{E}{2}$. For output voltage $V_{out} = 0$, S_1' and S_2 power switches must be on [18, 23].

The considerable advantages of DCM converter are as follows:

- Output voltage THD is significantly decreases by increasing the voltage levels which leads to reduction or elimination of output filter size.
- With regards to the fact that switches operates at the fundamental frequency, the Inverter efficiency is high.

- The implemented control procedure is simple.

The notable disadvantages of DCM inverter are as follows

- By increasing the number of voltage levels, the number of clamping diodes is increased drastically.
- It is complicated to control the real power flow of DCM converter in multi converter systems [18, 23].

4.2. Cascade multilevel (CM) converter

A CM inverter comprises series connections of H-bridge inverters which are supplied by isolated dc sources. The aforementioned isolated dc sources may be provided by WECS systems, batteries, or other voltage sources. The configuration of CM converter with isolated dc voltage sources is depicted in Fig.10.

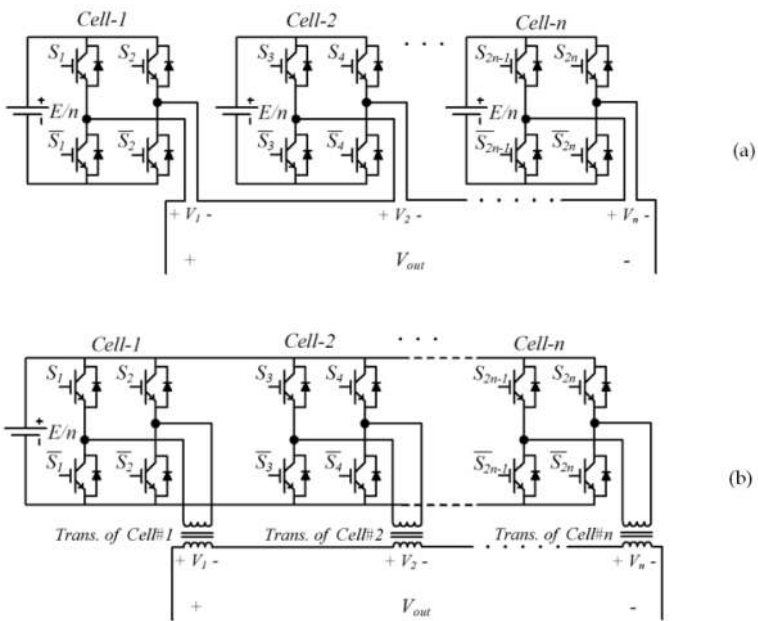

Figure 10. The 2n+1 levels cascade multilevel inverter: (a) with separated dc voltage sources. (b) with one dc voltage source and isolator transformers.

Each h-bridge inverter provides three output voltage levels which are 0 or $\pm E$. All five switch states for h-bridge inverter are shown in table 1. The output voltage of CM converter is obtained by the sum of inverter outputs. Hence, the CM inverter output voltage can be expressed as

$$v_{out} = \sum_{i=1}^n v_i \quad (8)$$

where n is the number of cells and v_i is the output voltage of cell i .

For n number of cells, the output voltage of CM converter has $2n + 1$ levels. For instance, in order to provide five level output voltage, two h-bridge cascaded converters with isolated dc voltage sources are needed. Switch states of mentioned five-level CM converter is depicted in table 2 [18, 23, 26].

The advantages of the CM inverter are as follows:

- CM needs the minimum number of components to provide the same number of staircase voltage levels in comparison with DCM and FCM converters.
- In order to reduce switching losses and device stresses, soft-switching techniques can be implemented on CM converter.

The disadvantage of the CM inverter is requirement of isolated dc voltage sources for real power conversions [18, 23, 26].

Output Voltage Level	State of (S1, S2, S3, S4)	Number of States
$+\frac{2}{2}E$	(1, 0, 1, 0)	1
$+\frac{1}{2}E$	(1, 0, 1, 1), (1, 0, 0, 0), (1, 1, 1, 0), (0, 0, 1, 0)	4
0	(1, 1, 1, 1), (1, 1, 0, 0), (0, 0, 0, 0), (0, 0, 1, 1)	4
$-\frac{1}{2}E$	(0, 1, 1, 1), (0, 1, 0, 0), (1, 1, 0, 1), (0, 0, 0, 1)	4
$-\frac{2}{2}E$	(0, 1, 0, 1)	1

Table 1. Switches states for a five-level CM inverter.

4.3. Flying capacitor multicell (FCM) converter

The FCM converters comprise ladder connection of FC cells. Each FC cell in FCM converter consists of a flying capacitor and a pair of switches with a complimentary state. In order to provide various levels at the inverter output, the commutation between adjacent cells with their FCs charged to the desired values is needed [24]. Hence, the voltage balancing of flying capacitors is indispensable issue in FCM converters. Appropriate operation of FCM converter depends on suitable voltage balancing of FCs [23, 24]. Applying the phase-shifted carrier pulse-width modulation (PSC-PWM) technique in FCM converter control system guarantees the FCs self-balancing process [24]. Typical configuration of FCM converter and the phase-shifted carrier pulse-width modulation (PSC-PWM) technique for five-level FCM inverter are shown in Fig.11 and Fig.12, respectively.

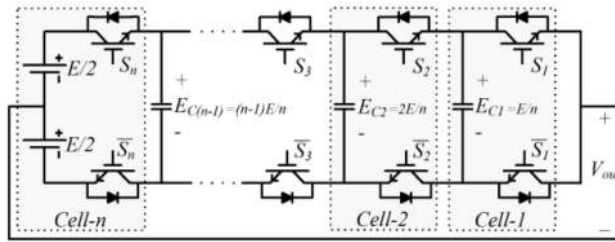

Figure 11. The n cells ($n + 1$ levels) FCM inverter.

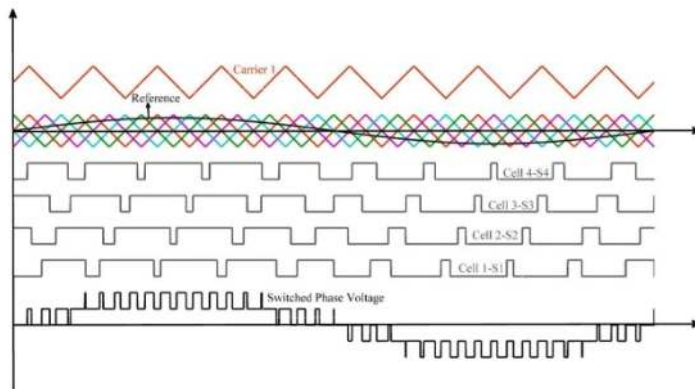

Figure 12. The phase-shifted carrier pulse-width modulation (PSC-PWM) technique for five-level FCM inverter.

The advantages of the FCM inverters are:

- FCM inverter does not require to isolated dc voltage sources. Hence, it has transformer-less operation capability.
- Clamping diodes are not needed to use in FCM inverters.
- There are plenty of redundant switching states which result inherent self-balancing property of the voltage across FCs.
- Switching stress is equally distributed between power switches.

The major disadvantages of the FCM inverter are:

- Numerous FCs is needed to provide high staircase output voltage levels.
- Implementing switching and control pattern can be more sophisticated and complicated [18, 23, 24].

The switches states of five-level FCM inverter is expressed in table 2.

Output Voltage Level	State of (S4, S3, S2, S1)	Number of States
$+\frac{2}{4}E$	(1, 1, 1, 1)	1
$+\frac{1}{4}E$	(1, 1, 1, 0), (1, 1, 0, 1), (1, 0, 1, 1), (0, 1, 1, 1)	4
0	(1, 1, 0, 0), (1, 0, 0, 1), (0, 0, 1, 1), (0, 1, 1, 0)	4
$-\frac{1}{4}E$	(0, 0, 0, 1), (0, 0, 1, 0), (0, 1, 0, 0), (1, 0, 0, 0)	4
$-\frac{2}{4}E$	(0, 0, 0, 0)	1

Table 2. Switches states for a five-level FCM inverter

4.4. Multilevel converters applications in wind energy conversion systems

Multilevel inverters provide more than two voltage levels. A desired output voltage waveform can be synthesized from the multiple voltage levels with significantly improved harmonic content, decreased output dv/dt , reduced electromagnetic interference, smaller filter inductance, and increased carrier ratio (R_c). Furthermore, low switching and conduction power losses, increased efficiency, fault tolerant, and high modularity are other valuable features of multilevel converters. There are a couple of topologies that provide multilevel voltages and are suitable for industrial applications.

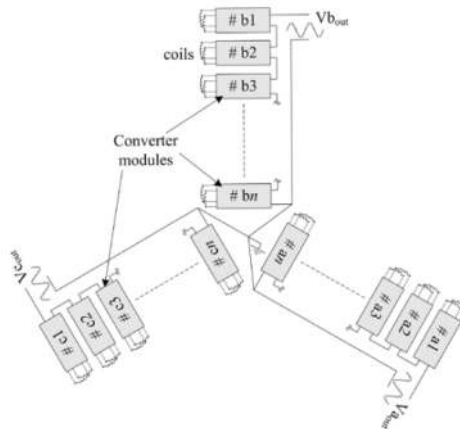

Figure 13. Electrical configuration of multiple winding stator[25].

With regards to above-mentioned multilevel converter topologies, it is clear that using multilevel converters will lead in increased complexity to control and implementation of power electronic conversion system. Among multilevel converters, DCM is widely used for wind energy conversion system because it needs just one power supply to provide desired output voltage. On the other hand, increasing in voltage levels of DCM causes expeditiously

increase in number of clamping diodes and complexity of control system. Thus, using CHB and FCM converters have been mentioned in couple of papers. In order to overcome the required isolated power supplies in these converters, input DC sources elimination methods have been proposed in some papers. Also, using novel structure of AFPMSG generators with variety of stator windings has been mentioned. For instance, in [25] new multi level conversion system is proposed. In order to provide multiple DC source to multilevel converter, multiple winding stator has been used in [25]. Electrical configuration of mentioned system and circuit diagram of proposed structure of converter are shown in Fig.13 and Fig.14, respectively.

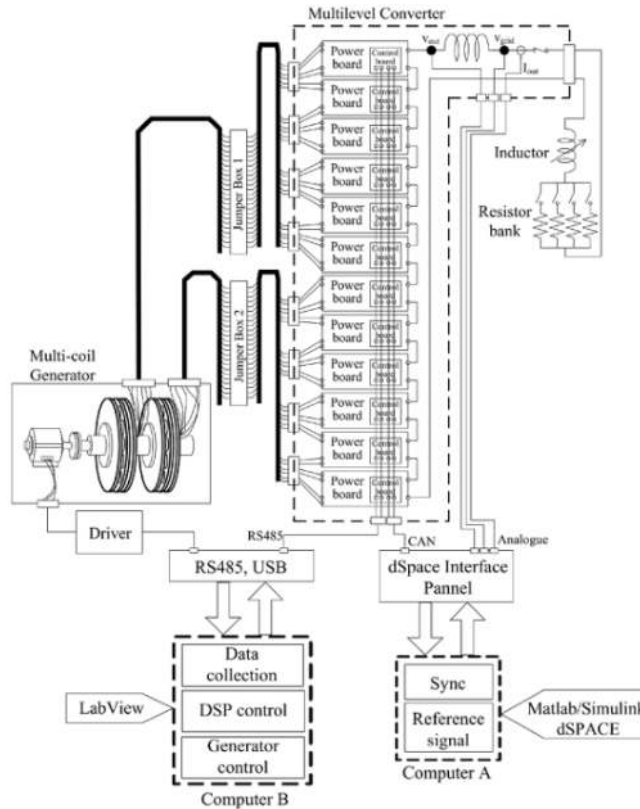

Figure 14. Circuit diagram of multilevel converter based on multiple winding stator [25].

5. Z-source inverters

V-source inverter is widely used in wind energy conversion systems. V-source inverters have the following demerits as theoretical and experimental point of view:

- The ac output voltage is limited below and cannot exceed the dc-rail voltage or the dc-rail voltage has to be greater than the ac output voltage. Therefore, the V-source inverter is a step-down inverter. For couple of applications where the available dc voltage is limited, increasing voltage is demanded to have wide-range operation capability. Hence, additional dc-dc boost converter is needed to obtain a desired ac output which increases system cost and decreases system efficiency.
- The upper and lower switches of each phase leg cannot be turned on at the same time either by purpose or by electromagnetic interference (EMI) noise. Otherwise, phase leg would be short-circuited. The shoot-through problem is emerged by EMI noises. Providing dead time between upper and lower switches which is used to prevent phase leg short-circuiting, will result in high THD at output voltage waveform.
- An output LC filter is needed for providing a sinusoidal voltage, which causes additional power loss and control complexity [28].

In order to overcome the above problems of the traditional V-source converters, [28] presents an Z-source converter for implementing dc-to-ac power conversion. Typical Z-source converter structure is depicted in Fig. 15. In this type of converter, unique impedance network is used to couple the converter main circuit to the power source, load, or another converter, for providing superior performances in comparison with traditional V-source converters where a capacitor is used. Hence, the Z-source converter dominates the aforementioned disadvantages and restrictions of the traditional V-source converter and provides a novel power conversion configuration. In Fig. 15, a two-port network that consists of a split-inductor L_1 and L_2 and capacitors C_1 and C_2 connected in X shape is employed to provide an impedance source (Z-source) coupling the inverter to the dc source, load, or another converter. The dc source can be a battery, diode rectifier, thyristor converter, fuel cell, a capacitor, or a combination of those. Fig. 15 shows two three-phase Z-source inverter configurations. The inductance L_1 and L_2 can be provided through a split inductor or two separate inductors.

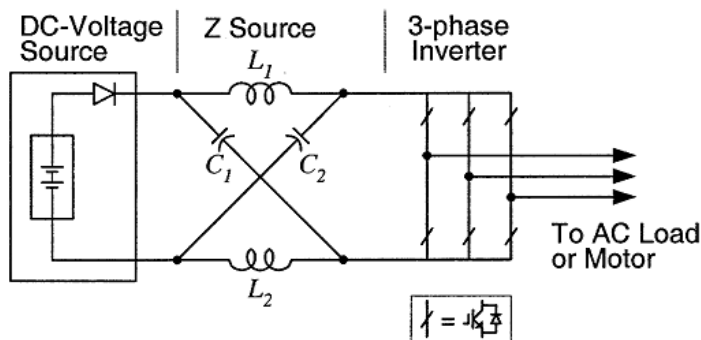

Figure 15. Z-source inverter configuration.

Fig.1 shows the traditional two-stage power conversion for wind energy conversion applications. Because wind turbine usually produce a voltage that changes widely depending on wind speed. For wind power generation, a dc–dc boost converter is needed because the V-source inverter cannot produce an ac voltage that is greater than the dc voltage. Z-source inverter can directly produce an ac voltage greater and less than the wind turbine voltage. So Z-source inverter is a combination of dc-dc boost converter and traditional VSI.

5.1. Quasi Z-source inverters

Multiple structures have been derived from main structure of Z-source inverter that is mentioned above. In this structure, the current drawn from the source is discontinuous. This causes couple of limitations in some applications, and a decoupling capacitor bank at the front end is sometimes used to prevent current discontinuity and protect the energy source. In order to prevail the frailties in the classical ZSI, quasi-Z-source inverters (qZSIs) have been proposed [29-31]. The qZSI provides a lower voltage stress on capacitors. The ratio between the dc-link voltage across the inverter bridge, v_{PN} , and the input dc voltage, V_{dc} (the boost factor of the classical ZSI and qZSI), can be expressed as

$$B = \frac{v_{PN}}{V_{dc}} = \frac{1}{1 - 2\frac{T_0}{T}} = \frac{1}{1 - 2D} \quad (9)$$

where T_0 is the interval of the shoot-through state during the switching period T and $D = T_0/T$ is the duty cycle ratio of shoot-through state.

The boost factor from (9) indicates that when D is between 0 and 0.5, B varies in $(1, \infty)$. The infinite value of B is not achievable in practical because of the parasitic effects found in the physical components. Therefore, the ZSI and qZSI are not appropriate for applications where both a high boost voltage and a buck voltage gain are required. To overcome the boost limitations in (9), some papers have recently focused on increasing the boost factor of the ZSI by adding the inductors, capacitors, and diodes to the Z-impedance network in order to produce a high dc-link voltage for the main power circuit from a very low input dc voltage. They are, namely, continuous-current diode/capacitor-assisted extended-boost quasi-ZSIs [32], switched-inductor ZSIs [33], switched-inductor quasi-ZSIs [34] and single-stage boost inverters with couple inductor [35].

5.1.1. Extended-Boost ZSI Topologies

In [32], new converter topologies are mainly categorized as diode-assisted boost or capacitor-assisted boost topologies. All these topologies can be modulated using the modulation methods proposed for the original ZSI. The other main advantage of these topologies is their expandability which was not possible with the original ZSI. In these topologies, in order to increase the boosting range, another stage can be cascaded at the front end without increasing the number of active switches. The only additions for each added new stage would be one

inductor, one capacitor, and two diodes for the diode-assisted case and one inductor, two capacitors, and one diode for the capacitor-assisted case. For each added new stage, the boost factor is increased by a factor of $1/(1 - D_s)$ in the case of the diode-assisted topology, where D_s is shoot-through duty ratio. In the case of capacitor-assisted topology, the boost factor is changed to $1/(1 - 3D_s)$ in comparison with $1/(1 - 2D_s)$ in the traditional topology. Furthermore, hybrid type of topologies can be achieved by combination of capacitor- and diode-assisted techniques, if the number of stages is larger than two [32]. Diode-assisted extended-boost qZSI topologies are shown in Fig.16.

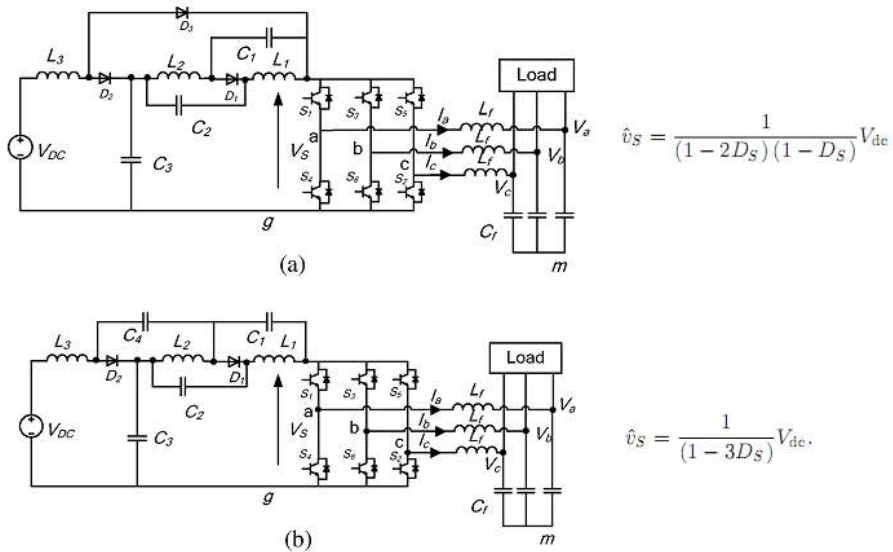

Figure 16. Extended-boost ZSI inverter (a) Diode-assisted extended-boost qZSI (b) Capacitor-assisted extended-boost qZSI [32].

In Fig.16, \hat{v}_s is the output voltage of impedance network of extended-boost ZSI inverter.

5.1.2. Switched Inductor Z-Source Inverter

Recently significant improvement of dc-dc conversion techniques such as switched capacitor (SC), switched inductor (SL), hybrid SC/SL, voltage multiplier cells and voltage lift techniques have been introduced in [33, 36-38], which are used to achieve the high step-up capacity in transformer-less and cascade configurations. The main purpose is to reach a high efficiency, high power density, and simple structures. In [33], the combination with the Z-source inverter and advanced dc-dc improvement techniques has been proposed. In [33], the concept of the SL techniques has been combined into the classical Z-source impedance network, and

consequently, a new SL Z-source impedance network has been proposed [33]. The new proposed topology is then defined the SL Z-source inverter is depicted in Fig.17.

The main characteristics are summarized as:

- The basic X-shape configuration is preserved.
- Only six diodes and two inductors are added in comparison with the traditional ZSI.
- The boost factor has been increased from $1/(1 - 2D)$ to $(1 + D)/(1 - 3D)$.
- The new structure is extensible for the further development using the coupled inductor techniques and other potential improving techniques [33].

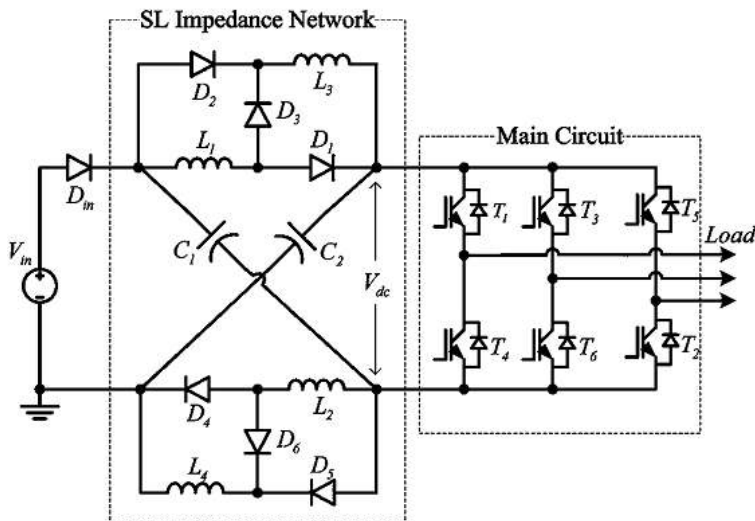

Figure 17. Switched inductor Z-source inverter [33].

5.1.3. Switched-Inductor Quasi-Z-Source Inverter

In order to overcome the shortcomings of the classical ZSI, quasi-ZSIs (qZSIs) have been proposed. qZSIs have many advantages, such as reducing passive component ratings and improving input profiles. In [34], the switched-inductor structure has been applied to the continuous input current quasi-Z-source topology to create a novel topology which is called an SL-qZSI. Compared with the SL-ZSI, the proposed SL-qZSI enhances input current, reduces the passive component count, and enhances reliability. Moreover, the shoot-through current, voltage stress on capacitors, and current stress on inductors and diodes in the proposed SL-qZSI are lower than in the SL-ZSI for the same input and output voltages. The proposed SL-qZSI avoids the inrush current at start-up, which may damage the devices [34]. Fig.18 shows the SL-qZSI topology.

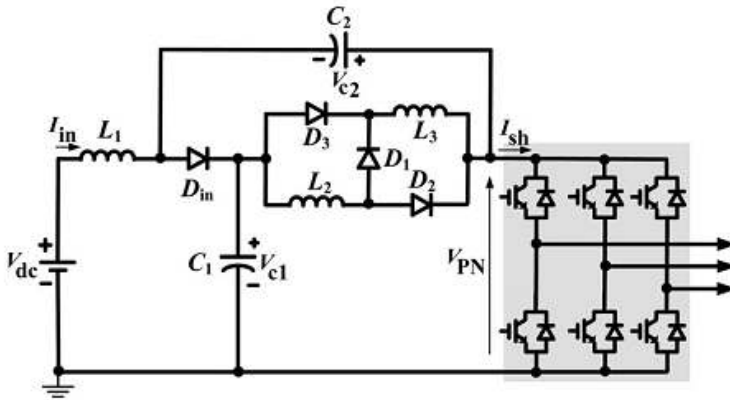

Figure 18. Switched-inductor quasi-Z-source inverter [34].

Regarding that no current flows to the main circuit during start-up, SL-qZSI topology provides inrush current elimination, in contrast with SL-ZSI topology. However, the inductors and capacitors in the proposed switched-inductor qZSI still resonate. Compared with a conventional continuous-current qZSI, the proposed inverter adds only three diodes and one inductor, and the boost factor increases from $1/(1 - 2D)$ to $(1 + D)/(1 - 2D - D^2)$.

5.1.4. Single-Stage Boost Inverter With Coupled Inductor

In [35] single-stage boost inverter with a unique impedance network that consisting coupled inductor has been proposed. The bus voltage can be stepped up by applying shoot-through zero state to accumulate and transfer energy within the impedance network. Similar to ZSI, the single-stage boost inverter completely avoids damaging devices during shoot-through zero states. So, it has enhanced reliability. Second, the inductors and capacitors do not have to be of high consistency which leads to easier circuit parameters design. Third, both shoot-through zero states and coupled inductor's turn ratio can be regulated to control the boost gain. So, the output voltage can be regulated in a wide range and can be stepped up to a higher value. Finally, the bus voltage equals the sum of the capacitor voltages, and it is higher than each capacitor voltage. This ensures status capacitor voltage ratings can be fully utilized. The single-stage boost inverter with coupled inductor is appropriate for applications where the input voltage has wide range variation from relatively low to higher level while output must have a stable ac voltage [35]. Single-stage boost Z-source inverter with coupled inductor is shown in Fig.19.

5.1.5. Enhanced-Boost Z-Source Inverters with Switched Z-Impedance

Fig. 20 shows the proposed Z-source inverter that produces high output voltage gain. In traditional Z-source inverters for high boosting voltage, low modulation index is required, so under these conditions output voltage will have low quality with high total harmonic distortion.

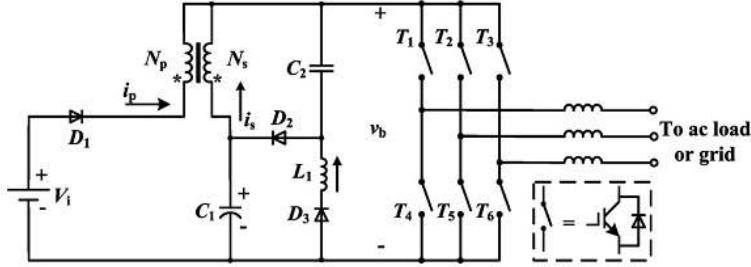

Figure 19. Single-stage boost Z-source inverter with coupled inductor [35].

tion. Compared with the conventional high-boost ZSI topologies, the proposed inverter by authors uses shorter shoot-through duration and larger modulation index to improve the output waveform quality [39].

The boost factor of proposed ZSI can be calculated as:

$$B = \frac{1}{2D^2 - 4D + 1} \quad (10)$$

The output ac voltage can be calculated by:

$$\hat{V}_{ac} = M.B. \frac{V_{in}}{2} = G. \frac{V_{in}}{2} \quad (11)$$

where

$$G = M.B = (0 \sim \infty) \quad (12)$$

is buck–boost factor. The buck–boost factor (G) can be controlled by changing D and M . Duty cycle of shoot-through, D , is limited by modulation index by the following relation:

$$D \leq 1 - M \quad (13)$$

The boost factor from (10) indicates that when D is between 0 and 0.29, B varies in $(1, \infty)$. However, the infinite value of B is not accessible due to parasitic effects of physical components. Even if a large value of D is used to produce the high boost gain, the modulation index must be small as indicated in (13). However, low modulation index, M will result in poorer spectral performances and low THD. Small M is generally not preferred since it leads to low

output waveform quality and high power losses due to lower order harmonics at output waveforms.

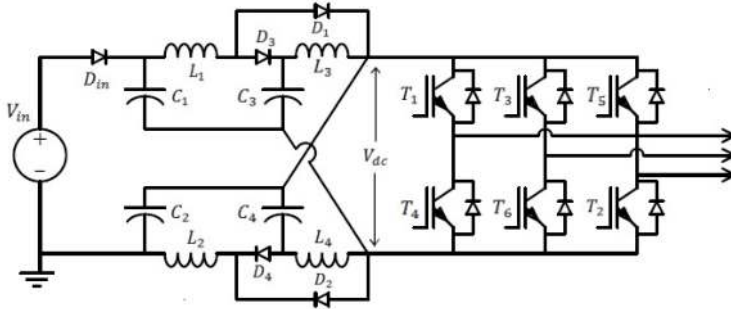

Figure 20. Proposed Z-source inverter with switched Z-impedance [39].

5.1.5.1. Simulation Results

The proposed topology shown in Fig. 20 has been simulated by PSIM software platform. The main circuit parameters for proposed topology are as follows:

$$L_1 = L_2 = L_3 = L_4 = 700 \mu\text{H}, \quad C_1 = C_2 = C_3 = C_4 = 500 \mu\text{F}$$

The switching frequency $F_s = 10\text{kHz}$

Three phase load $R = 60 \Omega$, $L = 5\text{mH}$,

DC input voltage $V_{in} = 100$

Fig. 21 shows that with the same duty ratio the proposed topology produces higher boost factor than diode assisted QZSI, alternate cascaded ZSI, conventional ZSI, and SL-ZSI. In other word the new topology requires lower duty ratio for the same boosting voltage. Lower duty ratio will lead in higher modulation index of M and lower THD at the output voltage. So this topology is very suitable for renewable energy conversion systems, without requirement of dc-dc converters. Fig. 22 shows the output voltage gain against modulation index for five topologies. In order to produce the same output voltage gain, the proposed topology uses higher modulation index than other two traditional methods.

Fig. 23 shows the simulation results for the proposed ZSI with shoot-through duty cycle of $D = 0.18$ and modulation index of $M = 0.82$. From (10), the boost factor, $B = 2.9$. From simulation results one can observe that the capacitors' voltage V_{c1} and V_{c3} are, respectively, boosted to 195 and 237.5 V in the steady state, and the peak dc-link voltage V_{dc} is boosted to 290 V. So the boosted factor can be calculated to be $290/100 = 2.9$. Meanwhile, the peak ac output phase voltage \hat{V}_{ac} has been boosted to 119 V. These results clearly verify the high boosting capability of the proposed ZSI.

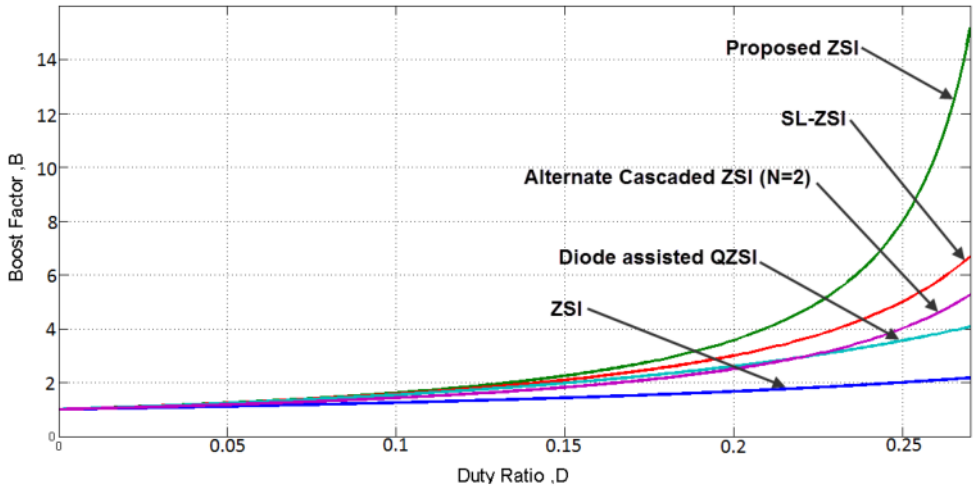

Figure 21. Boost Factor against the duty cycle of shoot-through.

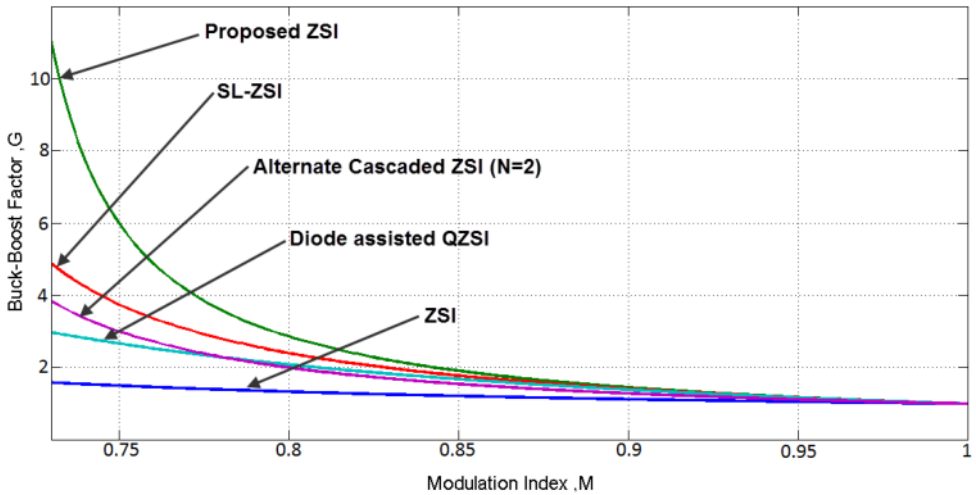

Figure 22. Buck-Boost factor against the modulation index.

5.1.5.2. Experimental Results

Fig. 24 shows the experimental results for proposed ZSI when shoot-through duty cycle $D = 0.18$ and modulation index $M = 0.82$. DC link voltage is boosted from 100 V to 268 V, which is slightly less than the calculated value ($2.9 \times 100 = 290$ V) from (10) due to the voltage reduction on the passive components, diodes, and switching devices. Capacitor voltages V_{c1} and V_{c3} are boosted to 186V, and 219 V, respectively. Meanwhile, the rms value of line to line output

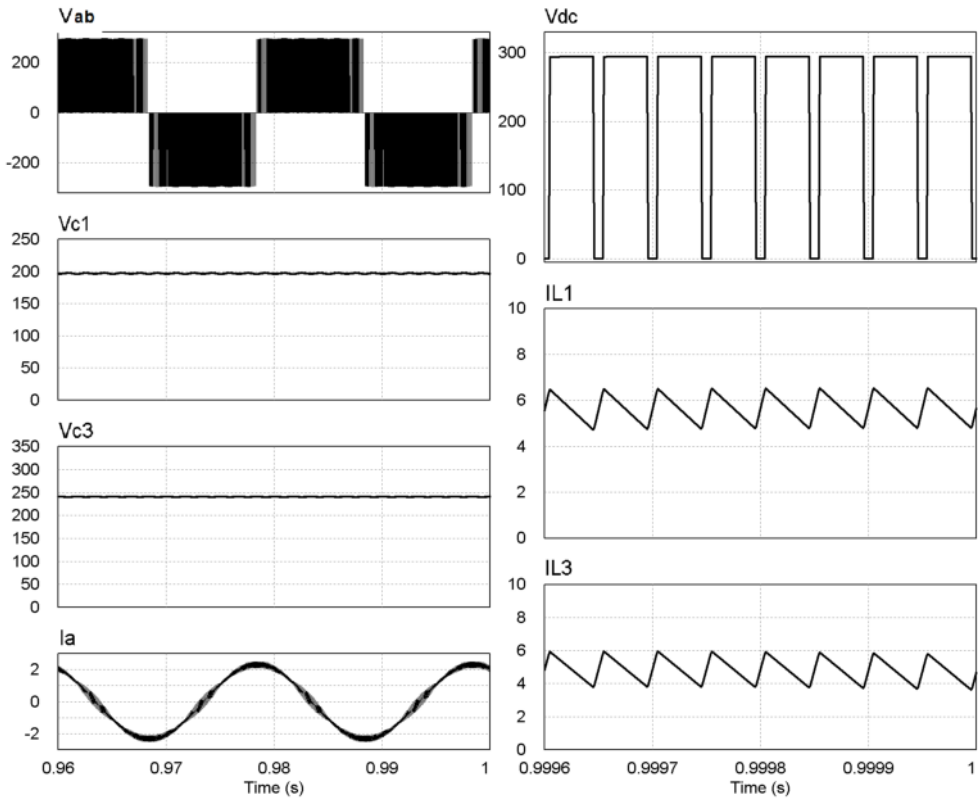

Figure 23. Simulation results for the proposed ZSI, $M=0.82$ and $D=0.18$.

voltage is 193V. Fig. 24 further shows the dc-link voltage, inductor current, and load current which clearly are similar to simulations except for some spikes and switching noises superimposed. These spikes and noises are not seen in simulation and are thus likely picked up from the hardware semiconductor switching. Because of proper snubber design, the MOFETs have enough protection against the spikes and noises. From Fig. 24 it is very clear that the peak dc-link voltage maintains constant value during the non-shoot-through states, and it is quite consistent with the theoretical value. The simulation and experimental results of Figs. 23 and 24 match well with each other and those of the theoretical analysis for the proposed inverter.

5.2. Trans Z-source Inverters

The voltage-fed Z-source inverter can have theoretically infinite voltage boost gain. However, the higher the voltage boost gain, the smaller the modulation index has to be used. In wind energy conversion applications, a low-voltage dc source has to be boosted to a desirable ac output voltage. A small modulation index results in a high voltage stress imposed on the inverter bridge. Transformer-based Z-source inverter (trans-ZSIs) has the possibility of

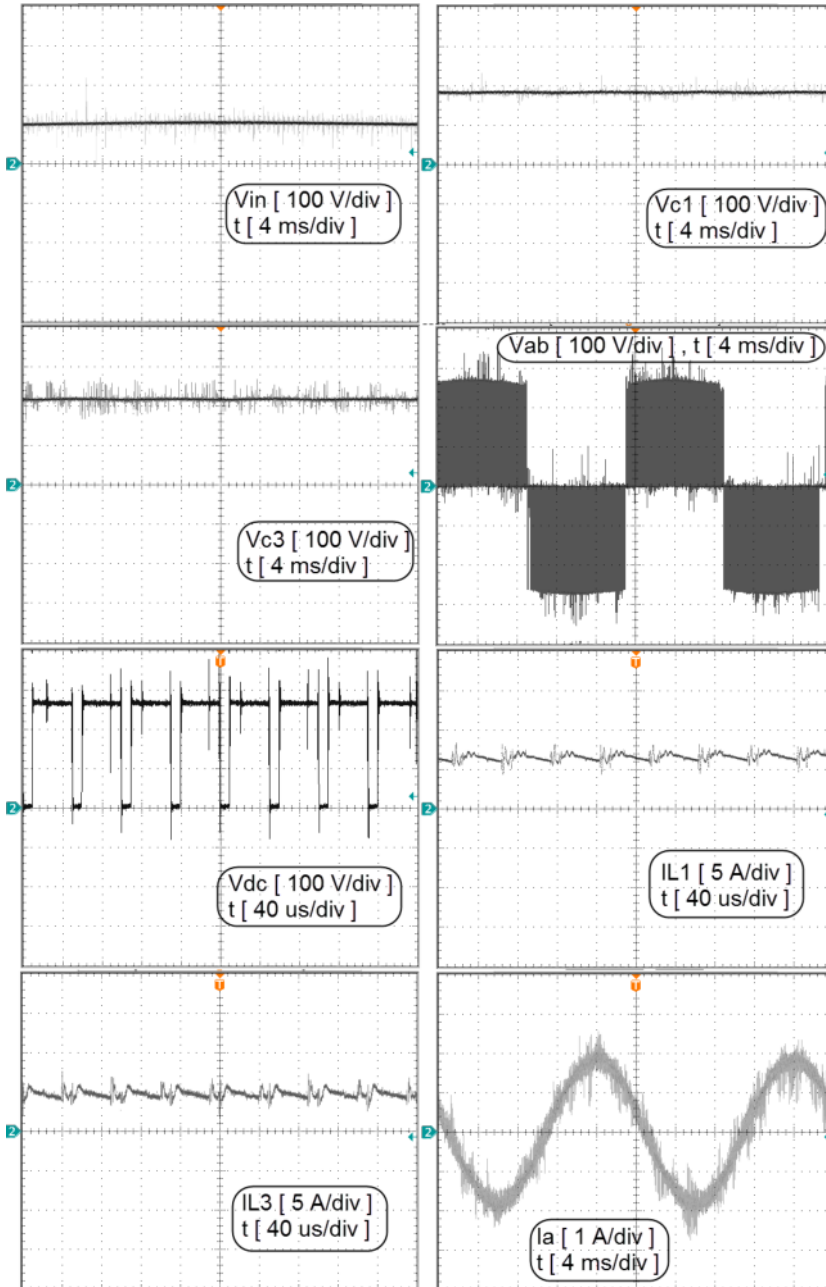

Figure 24. Experimental results for the proposed ZSI, $M=0.82$ and $D=0.18$.

increasing voltage gain with the minimum component count [31, 40]. Applying a transformer to the Z-source network has been introduced in the trans-Z-source. Voltage-fed trans-quasi-ZSI proposed in [40], where two inductors in the impedance Z-network are replaced by a transformer with a turn ratio of $n:1$ to achieve a high voltage gain. It comprises one transformer, one capacitor, and one diode. Fig. 25 depicts transformer-based Z-source inverter circuit diagram. The boost factor of this inverter is increased to

$$B = \frac{1}{1 - (1+n) \frac{T_0}{T}} = \frac{1}{1 - (1+n)D} \quad (14)$$

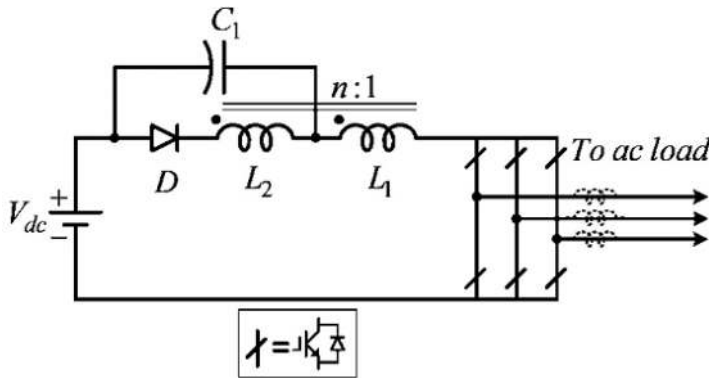

Figure 25. Transformer-based Z-source inverter [39].

5.3. Z-source converters applications in wind energy conversion systems

With regards to wind energy conversion systems that usually requires to increase the dc-link voltage to applicable standard voltage to supply ac load, high step-up voltage conversion must be used. In order to boost the dc link voltage in traditional wind energy conversion systems, power electronic transformer (PET) has widespread usage to convert the low dc-link voltage to applicable dc-voltage that is desirable in dc-to-ac inverters. Circuit diagram of traditional energy conversion system based on PET is depicted in Fig. 26.

In recent wind energy conversion systems, power electronic transformer (PET) is replaced with ZSI, qZSI and trans-ZSI high step-up converters to convert low dc-link voltage to desirable dc link voltage. This will lead in power electronic devices reduction and power conversion stages reduction in wind energy conversion system. Application of ZSI in renewable energy conver-

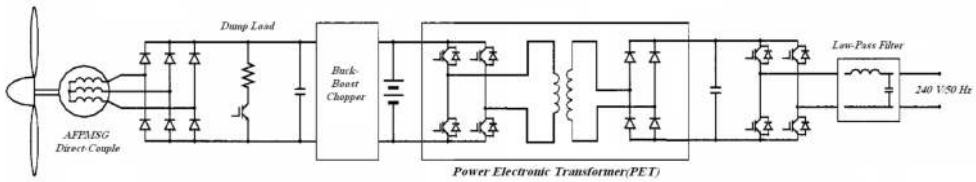

Figure 26. Wind energy conversion system based on power electronic transformer (PET).

tion systems will increase the power conversion reliability and decrease system costs. Fig. 27 shows typical configuration of wind energy conversion system based on ZSI inverters.

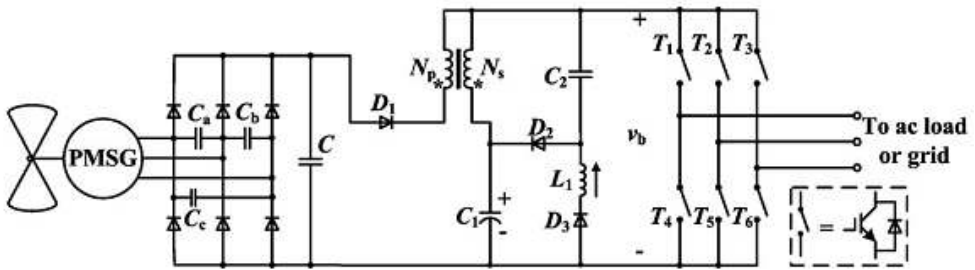

Figure 27. Typical configuration of wind energy conversion system based on single-stage boost inverter with coupled inductor [35].

6. Conclusion

In this chapter, various power electronic circuit topologies for small-scale wind energy conversion systems are investigated and considered. In order to convert wind turbine generator voltage to desirable and suitable output voltage, power electronic converters should be applied between wind turbine generator and load. In order to utilize maximum power point tracking methods on wind turbine to exploit maximum power from wind energy conversion system power electronic conversion system should have high efficiency and variable and high boost capability. To achieve this aim, new generator configuration and various Z-source converters which are proposed in literature are considered in this chapter. Furthermore, novel configuration of ZSI has been proposed and introduced by authors. Compared with the conventional ZSI, diode assisted QZSI, alternate cascaded ZSI ($N=2$), and SL-ZSI, the proposed inverter has the highest boosting ability. The proposed inverter uses shorter shoot-through duration and larger modulation index to improve the output waveform quality.

Author details

Mostafa Abarzadeh^{1*}, Hossein Madadi Kojabadi¹ and Liuchen Chang²

*Address all correspondence to: mst.abarzadeh@gmail.com

¹ Department of Electrical Engineering, Sahand University of Technology, Tabriz, Iran

² Department of Electrical and Computer Engineering, University of New Brunswick, NB, Canada

References

- [1] Abarzadeh M., Madadi kojabadi H., Chang L. Small Scale Wind Energy Conversion Systems. In: Al-Bahadly I., editor. Wind Turbines: InTech; 2011. P639-652.
- [2] Abarzadeh M., Madadi kojabadi H., Chang L. Power Electronics in Small Scale Wind Turbine Systems. In: Rupp Carriveau, editor. Advances in Wind Power: InTech; 2012. P305-335.
- [3] Yuan Lo K., Ming Chen Y., Ruei Chang Y: MPPT Battery Charger for Stand-Alone Wind Power System. IEEE Transactions on Power Electronics, 2011; 26(6) 1631 - 1638.
- [4] Smith J., Thresher R., Zavadil R., DeMeo E., Piwko R., Ernst B., and Ackermann T: A mighty wind. IEEE Power and Energy Magazine, 2009; 7(2) 41-51.
- [5] Nayar C., Dehbonei H., Chang L. A Low Cost Power Electronic Interface for Small Scale Wind Generators in Single Phase Distributed Power Generation System. In: Australasian Universities Power Engineering Conference (AUPEC); 25-28 September 2005; Hobart. IEEE; 2005.
- [6] Pathmanathan M, Tang C, Soong W.L, Ertugrul N. Comparison of power converters for small-scale wind turbine operation. In: Australasian Universities Power Engineering Conference (AUPEC); 14-17 December 2008; Sydney. IEEE; 2008. p. 1-6
- [7] Borowy B. S., Salameh Z. M.: Dynamic response of a stand-alone wind energy conversion system with battery energy storage to a wind gust. IEEE Transactions on Energy Conversion. 1997; 12(1) 73–78.
- [8] Billinton R., Bagen, Cui Y.: Reliability evaluation of small standalone wind energy conversion systems using a time series simulation model. Generation, Transmission and Distribution, IEE Proceedings, 2003; 150(1) 96–100.
- [9] Bagen, Billinton R., Evaluation of different operating strategies in small stand-alone power systems. IEEE Transactions on Energy Conversion, 2005; 20(3) 654–660.

- [10] Singh B., Kasal G.K: Solid state voltage and frequency controller for a stand alone wind power generating system. *IEEE Transactions on Power Electronics*, 2008;23(3) 1170–1177.
- [11] Chen Z., Spooner E: Grid interface options for variable-speed, permanent-magnet generators. *Electric Power Applications, IEE Proceedings*, 1998; 145(4) 273–283.
- [12] Chen Z., Spooner E: Grid power quality with variable-speed wind turbines. *IEEE Transactions on Energy Conversion*, 2001; 16(2) 148–154.
- [13] Probst O., Martinez J., Elizondo J., Monroy O. Small Wind Turbine Technology In: Al-Bahadly I., editor. *Wind Turbines: InTech*; 2011. P107-136.
- [14] Muljadi E., Forsyth T., Butterfield C.P. Soft-stall control versus furling control for small wind turbine power regulation. In: *Wind power Conference proceedings*; 27 April-1 May 1998; Bakersfield, CA.
- [15] Muljadi E., Pierce K., Migliore P: Soft-stall control for variable-speed stall-regulated wind turbines, *Journal of Wind Engineering and Industrial Aerodynamics*. 2000; 85(3) 277-291.
- [16] Bialasiewicz J.T. Furling control for small wind turbine power regulation. In: *IEEE International Symposium on Industrial Electronics (ISIE)*; 9-11 June 2003. IEEE; 2003.
- [17] Blaabjerg F., Liserre M., Ma K.: *Power Electronics Converters for Wind Turbine Systems*. *IEEE Transactions on Power Electronics*, 2012; 48(2) 708 - 719.
- [18] Rashid M.H. *Power Electronics, circuits, devices and applications*, 3rd edition: Prentice-Hall; 2007.
- [19] Keith H. Billings. *Switchmode power supply handbook*: McGraw-Hill; 1999.
- [20] Marty Brown. *Power Supply Cookbook*, 2nd edition: Butterworth–Heinemann; 2001.
- [21] Czarkowski D. DC-DC Converters. In: Rashid M.H. editor. *Power Electronics Handbook*: ACADEMIC PRESS; 2001. P211-223.
- [22] Espinoza J.R. Inverters In: Rashid M.H. editor. *Power Electronics Handbook*: ACADEMIC PRESS; 2001. P225-267.
- [23] Abarzadeh M. *Modelling, Design and Implementation of Grid Connected Small Scale Wind Generation System*. Msc thesis. Sahand University of Tech; 2011.
- [24] Dargahi V., Khoshkbar Sadigh A., Abarzadeh M., Alizadeh Pahlavani M.R., Shoulaie A: Flying Capacitors Reduction in an Improved Double Flying Capacitor Multicell Converter Controlled by a Modified Modulation Method. *IEEE Transactions on Power Electronics*, 2012; 27(9) 3875 - 3887.
- [25] Ng, C.H.; Parker, M.A.; Ran, L.; Tavner, P.J.; Bumby, J.R.; Spooner, E.: A Multilevel Modular Converter for a Large, Light Weight Wind Turbine Generator. *IEEE Transactions on Power Electronics*, vol.23, no.3, pp.1062, 1074, May 2008

- [26] M. Veenstra and A. Rufer, Control of a hybrid asymmetric multilevel inverter for competitive medium-voltage industrial drives. *IEEE Transactions on Industry Applications*, vol. 41, no. 2, pp. 655–664, Mar./Apr. 2005.
- [27] Pulikanti, S.R.; Agelidis, V.G.: Hybrid Flying-Capacitor-Based Active-Neutral-Point Clamped Five-Level Converter Operated With SHE-PWM, *IEEE Transactions on Industrial Electronics*, vol.58, no.10, pp.4643, 4653, Oct. 2011
- [28] Fang Zheng Peng: Z-source inverter, *IEEE Transactions on Industry Applications*, vol.39, no.2, pp.504, 510, Mar/Apr 2003
- [29] J. Anderson and F. Z. Peng, Four quasi-Z-source inverters. In: *Power Electronics Specialists Conference (PESC)*; 15-19 June 2008; Rhodes. IEEE; 2008; pp. 2743–2749.
- [30] P. C. Loh, F. Gao, and F. Blaabjerg: Embedded EZ-source inverters, *IEEE Transactions on Industry Applications*, vol. 46, no. 1, pp. 256–267, Jan./Feb. 2010.
- [31] Minh-Khai Nguyen; Young-Cheol Lim; Yi-gon Kim: TZ-Source Inverters, *IEEE Transactions on Industrial Electronics*, vol.60, no.12, pp.5686, 5695, Dec. 2013
- [32] C. J. Gajanayake, F. L. Luo, H. B. Gooi, P. L. So, and L. K. Siow: Extended boost Z-source inverters, *IEEE Transactions on Power Electronics*, vol. 25, no. 10, pp. 2642–2652, Oct. 2010.
- [33] M. Zhu, K. Yu, and F. L. Luo: Switched-inductor Z-source inverter, *IEEE Transactions on Power Electronics*, vol. 25, no. 8, pp. 2150–2158, Aug. 2010.
- [34] M. K. Nguyen, Y. C. Lim, and G. B. Cho: Switched-inductor quasi-Z-source inverter, *IEEE Transactions on Power Electronics*, vol. 26, no. 11, pp. 3183–3191, Nov. 2011.
- [35] Y. Zhou and W. Huang: Single-stage boost inverter with couple inductor, *IEEE Transactions on Power Electronics*, vol. 27, no. 4, pp. 1885–1893, Apr. 2012.
- [36] A. Ioinovici: Switched-capacitor power electronics circuits, *IEEE Circuits and Systems Magazine*, vol. 1, no. 4, pp. 37–42, Sep. 2001.
- [37] H. S. H. Chung, A. Ioinovici, and W. L. Cheung: Generalized structure of bi-directional switched-capacitor dc/dc converters, *IEEE Transactions on Circuits and Systems I: Fundamental Theory and Applications*, vol. 50, no. 6, pp. 743–753, Jun. 2003.
- [38] B. Axelrod, Y. Berkovich, and A. Ioinovici: Switched-capacitor/switched-inductor structures for getting transformerless hybrid dc-dc PWM converters, *IEEE Transactions on Circuits and Systems I: Fundamental Theory and Applications*, vol. 55, no. 2, pp. 687–696, Mar. 2008.
- [39] H. Fathi Kivi, and H. Madadi Kojabadi, Enhanced boost Z-source inverters with switched Z-impedance, *IEEE Transactions on Industrial Electronics*, vol. 63, no. 2, pp. 691–703, 2016.

- [40] W. Qian, F. Z. Peng, and H. Cha, Trans-Z-source inverters, *IEEE Transactions on Power Electronics*, vol. 26, no. 12, pp. 3453–3463, Dec. 2011.

