Temperature Effects on Liquid Crystal Nonlinearity

Lamees Abdulkaeem Al-Qurainy and
Kais A.M. Al Naimee

Additional information is available at the end of the chapter

<http://dx.doi.org/10.5772/intechopen.70414>

Abstract

The effect of temperature variation on nonlinear refractive indices of several types of liquid crystal (LC) compounds has been reported. Five samples have been investigated: two pure components (E7, MLC 6241-000) and three mixtures are obtained by mixing the previous two in different proportions. Birefringence, the average refractive index and the temperature gradients of refractive indices of the LCs are determined. The variations in refractive indices and birefringence were fitted theoretically using the modified Vuks equation. Excellent agreement is obtained between the fitted values and experimental data. Finally, the bistability of nonlinear refractive indices with temperature of liquid crystal (LC) compounds has been studied. The bistability of liquid crystals based on temperature is clearly observed for all samples. Also, the extraordinary refractive index has larger bistability than the ordinary refractive index. The measurements are performed at 1550 nm wavelength using wedged cell refractometer method.

Keywords: extraordinary, refractive index, liquid crystal, birefringence, order parameter

1. Introduction

Liquid crystals exhibit optical anisotropy or birefringence (Δn). This is an essential physical property of liquid crystals and is a key element in how they are implemented in the display [1, 2], photonic devices [3], communications signal processing [4], and beam steering [5].

When light propagates through anisotropic media such as liquid crystals, it will be divided into two rays which travel through the material at different velocities, and therefore have different refractive indices, the ordinary index (n_o), and extraordinary index (n_e), and the difference is called as birefringence or double refraction ($\Delta n = n_e - n_o$). Depending on the values of n_e and n_o , birefringence can be positive or negative [6, 7].

Temperature plays a fundamental role in affecting the refractive indices of LCs. As the temperature increases, ordinary (n_o) and extraordinary (n_e) refractive indices of LCs behave differently from each other [8, 9].

Several techniques have been studied to describe the temperature effect on LC refractive indices. Horn measured the refractive indices as a function of temperature throughout the nematic phase of 4-n-pentyl-4-cyanobiphenyl (5CB) and the smectic A and nematic phases of 4-n-octyl-4-cyanobiphenyl (8CB) using the method of Pellet and Chatelain at the wavelength (589 and 632.8 nm) [10]. Wu developed a single-band model and a three-band model for understanding the refractive index dispersions of liquid crystals. The three- and two-coefficient Cauchy equations based on the three-band model for the wavelength- and temperature-dependent refractive indices of anisotropic liquid crystals were derived by Jun Li and Wu. For low birefringence liquid crystal mixtures, the two-coefficient Cauchy model works equally well as the three-coefficient model in the off-resonance spectral region [11]. A four-parameter model for describing the temperature effect on the refractive indices of LCs based on the Vuks equation was derived by Jun Li et al. Four different LC materials with different birefringence were used to validate these parameters. An excellent agreement between theory and experiment was obtained [12]. Jun Li et al. measured the refractive indices of E7 LC mixture at six visible and two infrared ($\lambda = 1.55$ and $10.6 \mu\text{m}$) wavelengths at different temperatures using Abbe and wedged cell refractometer methods [13]. In the present chapter, the temperature effect on nonlinear refractive indices of several types of liquid crystal (LC) compounds has been studied. In the beginning, the mathematical models are discussed. Second, using the refractive indices data, other parameters can be determined, such as birefringence (Δn), average refractive indices, and the temperature gradient of refractive indices (dn_o/dT , dn_e/dT). Finally, the bistability of nonlinear refractive indices with temperature of LC is also reported. The measurements performed at 1550 nm wavelength using wedged cell refractometer method. The variation in refractive indices was fitted theoretically using the modified four-parameter model, which is based on the Vuks equation.

2. Modeling

The classical Clausius-Mossotti equation correlates the dielectric constant (ϵ) of an isotropic media with molecular packing density (N), which means the number of molecules per unit volume and molecular polarizability (α) are as follows [6, 14, 15]

$$\frac{\epsilon - 1}{\epsilon + 2} = \frac{4\pi}{3} N\alpha \quad (1)$$

The Lorentz-Lorenz equation correlates the refraction index of anisotropic medium with molecular polarizability at optical frequencies and obtained the following equation [14, 15]

$$\frac{n^2 - 1}{n^2 + 2} = \frac{4\pi}{3} N\alpha \quad (2)$$

For an isotropic LC, the ordinary and extraordinary refractive indices are determined by corresponding ordinary and extraordinary molecular polarizability α_o and α_e . Vuks modified the Lorentz-Lorenz equation by assuming that the internal field in a liquid crystal is equal in all directions, and therefore produce a semi-empirical equation correlating macroscopic refractive index with microscopic molecular polarizability [11, 15].

$$\frac{n_{e,o}^2 - 1}{\langle n^2 \rangle + 2} = \frac{4\pi N}{3} \alpha_{e,o} \quad (3)$$

n_e and n_o are the extraordinary and ordinary refractive indices, $\langle n^2 \rangle$ is defined as $\langle n^2 \rangle = (n_e^2 + 2n_o^2)/3$

The temperature-dependent LC refractive indices based on Vuks model can be expressed by the average refractive index $\langle n \rangle$ and birefringence Δn as [11, 16],

$$n_e = \langle n \rangle + \frac{2}{3} \Delta n \quad (4)$$

$$n_o = \langle n \rangle - \frac{1}{3} \Delta n \quad (5)$$

On the other hand, the LC birefringence is linearly proportional to the order parameter S . Through Haller's semi-empirical equation, the order parameter can be approximated as

$$S = \left(1 - \frac{T}{T_c}\right)^B \quad (6)$$

where T is the operating temperature, T_c is the clearing temperature of LC material, and B is the material constant, for many LC compounds and mixtures studied $\beta = (0.2-0.25)$. Thus, the temperature-dependent Δn can be written as

$$\Delta n(T) = (\Delta n)_o \left(1 - \frac{T}{T_c}\right)^\beta \quad (7)$$

where $(\Delta n)_o$ is the LC birefringence in the crystalline state at absolute zero ($T = 0$ K). From Eqs. (6) and (7), the order parameter can be written as:

$$S = \frac{\Delta n}{(\Delta n)_o} \quad (8)$$

The average refractive index decreases linearly with increasing temperature as [16]:

$$\langle n \rangle = A - BT \quad (9)$$

Substituting Eqs. (7) and (9) back to Eqs. (4) and (5), the modified four-parameter model for describing the temperature effect on the LC refractive indices is obtained [17-19]:

$$n_e(T) \approx A - BT + \frac{2(\Delta n)_o}{3} \left(1 - \frac{T}{T_c}\right)^\beta \quad (10)$$

$$n_o(T) \approx A - BT - \frac{(\Delta n)_o}{3} \left(1 - \frac{T}{T_c}\right)^\beta \quad (11)$$

Eqs. (10) and (11) contain four unknown parameters A , B , $(\Delta n)_o$, and β . The parameters A and B can be obtained by fitting the temperature-dependent average refractive index using Eq. (9), while $(\Delta n)_o$ and β can be obtained by fitting the birefringence data Δn as a function of temperature using Eq. (7). By taking temperature derivatives of Eqs. (10) and (11), the temperature gradient for n_e and n_o can be derived [9, 19–24].

$$\frac{dn_e}{dT} = -B - \frac{2\beta(\Delta n)_o}{3T_c \left(1 - \frac{T}{T_c}\right)^{1-\beta}} \quad (12)$$

$$\frac{dn_o}{dT} = -B + \frac{\beta(\Delta n)_o}{3T_c \left(1 - \frac{T}{T_c}\right)^{1-\beta}} \quad (13)$$

3. Experimental refractive index

Five samples have been investigated in this work; two of them are E7 and MLC 6241-000 samples, the clearing temperatures are 333 and 373.7 K, respectively. The other three have been obtained by mixing the previous two liquid crystals in different proportions (75% E7 with 25% MLC 6241-000, 50% E7 with 50% MLC 6241-000, and 25% E7 with 75% MLC 6241-000). The clearing temperature (T_c) of three mixture samples is measured using hot-stage optical microscope, and they are found to be 348, 353, and 368 K, respectively.

The effect of temperature variation on nonlinear refractive indices of these liquid crystal compounds has been reported using wedged cell refractometer method. The cell is made up of two glass substrates separated by two spacers that have different thickness as shown in **Figure 1**. The wedged angle was measured using an optical method [9], and the angle value of five samples is shown in **Table 1**.

The experimental setup used during this work is shown in **Figure 2**, and a more detailed description of this setup and the measurement method can be found in [9]. The laser beam is divided into two rays, when it passes through LC sample because of birefringence of LC, the values of two refractive indices (n_o and n_e) of the liquid crystal can be calculated by these equations

$$n_o = \frac{\sin(\theta + \delta_o)}{\sin\theta} \quad (14)$$

$$n_e = \frac{\sin(\theta + \delta_e)}{\sin\theta} \quad (15)$$

where θ is the angle of the wedged formed by two plates, δ_o and δ_e are the angles formed by two beams R_o and R_e .

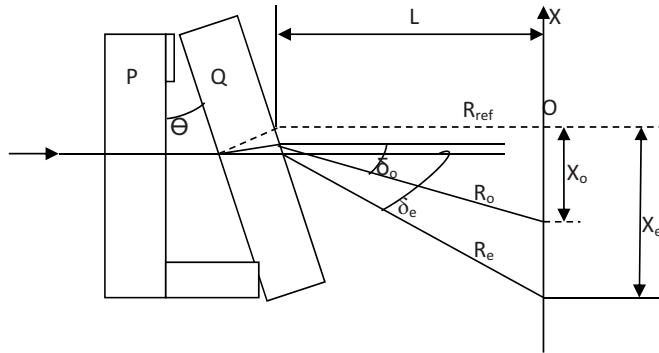

Figure 1. The used liquid crystal wedged cell.

Sample	Angle
E7	0.036215581
25% E7 with 75% MLC 6241-000	0.036635508
50% E7 with 50% MLC 6241-000	0.049305551
75% E7 with 25% MLC 6241-000	0.032724923
MLC 6241-000	0.052359877

Table 1. The angle's value formed by the two substrates of five samples.

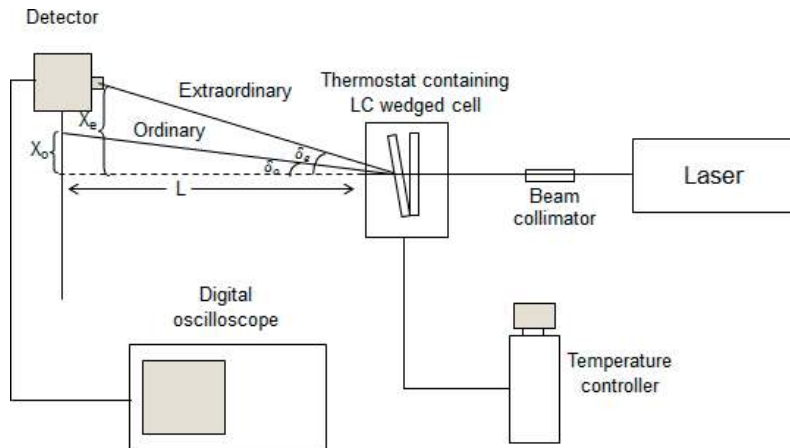

Figure 2. The experimental setup for the measurement of the refractive indices of LC.

$$\delta_o = \tan^{-1}\left(\frac{x_o}{D}\right) \quad (16)$$

$$\delta_e = \tan^{-1}\left(\frac{x_e}{D}\right) \quad (17)$$

So that

$$n_o = \frac{\sin(\theta + \tan^{-1}(x_o/D))}{\sin\theta} \quad (18)$$

$$n_e = \frac{\sin(\theta + \tan^{-1}(x_e/D))}{\sin\theta} \quad (19)$$

These measurements have been repeated many times by changing the temperature of the LC sample to measure the refractive indices at different temperatures. Also, this experiment has been repeated by decreasing the temperature of LC sample to study the bistability of liquid crystal due to temperature.

4. Results and discussions

4.1. Nonlinear refractive index

The refractive indices of the five liquid crystals were measured using wedged cell refractometer method at 1550 nm wavelength [9]. **Figure 3** shows the temperature dependence of the refractive indices n_o and n_e of E7 and MLC 6241-000. Red squares and blue circles are experimental data for refractive indices n_e and n_o of E7 and MLC 6241-000, respectively. The solid curves are fittings using the four-parameter model Eqs. (10) and (11). The fitting parameters are listed in **Table 2**.

The temperature dependence of refractive indices of three LC mixtures is shown in **Figure 4**. Blue squares, green triangles, and red circles represent the refractive indices of (50% E7 with 50% MLC 6241-000, 25% E7 with 75% MLC 6241-000, and 75% E7 with 25% MLC 6241-000), respectively. The solid curves are fittings using Eqs. (10) and (11).

Brugioni et al. also studied the temperature effect on nonlinear refractive indices of E7 liquid crystal at mid-infrared region (10.6 μm) using a wedge cell refractometer method as shown in **Figure 5** [13, 25].

Figure 6 shows the wavelength-dependent refractive indices of E7 at $T = 25^\circ\text{C}$. Squares and circles represent the n_e and n_o of E7 in the visible region, while the downward and upward triangles stand for the measured data at $\lambda = 1.55$ and $10.6 \mu\text{m}$, respectively [25]. **Figure 6** also indicates that the refractive indices will saturate in the far-infrared region, the agreement between experiment and theory is very good.

The temperature-dependent birefringence of E7 and MLC 6241-000 at 1550 nm is shown in **Figure 7**. Blue squares and red circles represent the birefringence of E7 and MLC 6241-000,

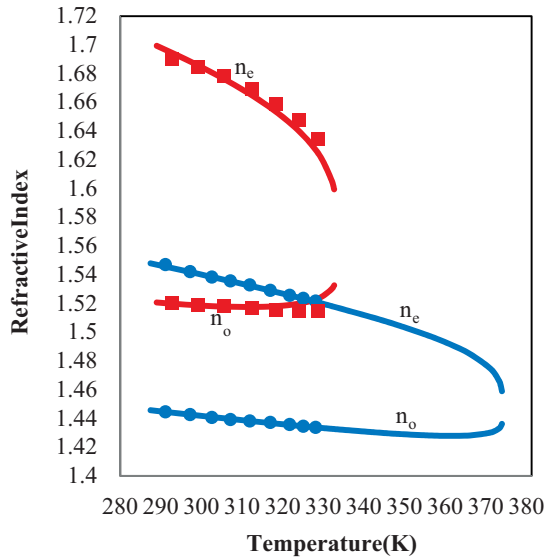

Figure 3. Temperature dependent refractive indices of E7 and MLC 6241-000 at $\lambda = 1550$ nm. Red squares and blue circles represent the refractive indices n_e and n_o of E7 and MLC 6241-000, respectively. The solid curves are the fitting using Eqs. (10) and (11).

LC materials	$\langle n \rangle$		Δn	
	A	B (K^{-1})	$(\Delta n)_0$	β
E7	1.750172	5.88×10^{-4}	0.301812	0.259542
25% E7 with 75% MLC 6241-000	1.61647	4.17×10^{-4}	0.153497	0.246991
50% E7 with 50% MLC 6241-000	1.622715	4.18×10^{-4}	0.189193	0.22493
75% E7 with 25% MLC 6241-000	1.650715	4.49×10^{-4}	0.182306	0.204806
MLC 6241-000	1.6008	4.21×10^{-4}	0.147301	0.248339

Table 2. Fitting parameters for the average refractive index $\langle n \rangle$ and birefringence Δn of five LCs at 1550 nm.

respectively, while solid lines are fitting results using Eq. (7). The fitting parameters for these samples are also listed in **Table 2**. Through fittings, we obtain parameters $(\Delta n)_0$ and β . As shown in **Figures 3, 4, and 7**, the four-parameter model fits the experimental data of samples E7 and MLC 6241-000 very well.

Figure 8 shows the temperature-dependent birefringence of three mixing samples. Blue triangles, green circles, and red squares, represent the birefringence LCs of (50% E7 with 50% MLC 6241-000, 25% E7 with 75% MLC 6241-000, and 75% E7 with 25% MLC 6241-000), respectively. The solid lines are fitting curves using Eq. (7). The LC mixture (50% E7 with 50% MLC 6241-000) has higher birefringence.

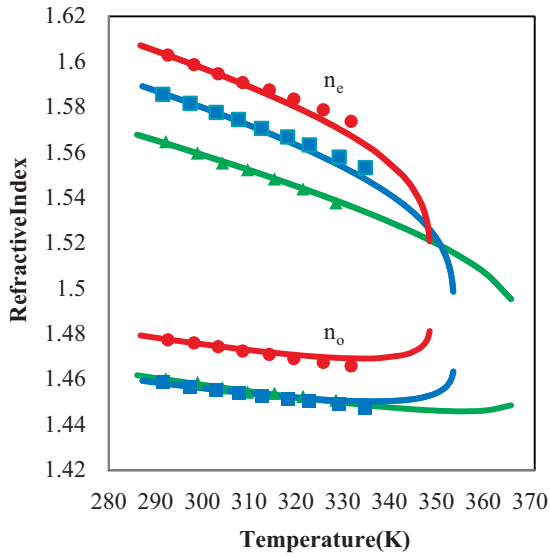

Figure 4. Temperature-dependent refractive indices of three mixture samples at $\lambda = 1550$ nm. Red circles, blue squares, and green triangles represent the refractive indices n_e and n_o of (75% E7 with 25% MLC 6241-000, 50% E7 with 50% MLC 6241-000, and 25% E7 with 75% MLC 6241-000), respectively. The solid curves are the fitting using Eqs. (10) and (11).

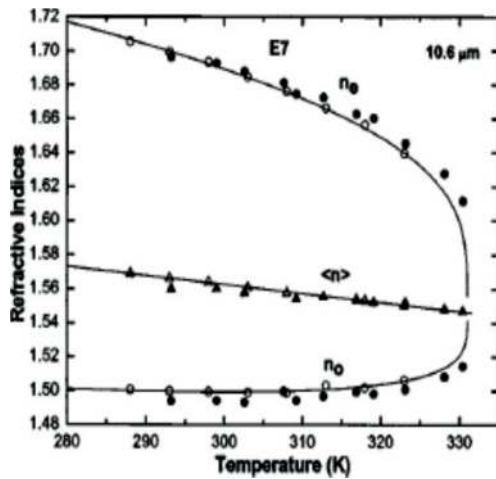

Figure 5. Temperature-dependent refractive indices of E7 at $10.6 \mu\text{m}$. The filled circles are the refractive indices measured by the wedged LCell refractometer method. The filled triangles are the average refractive index calculated by the experimental data. The open circles represent n_o and n_e extrapolated from the experimental data measured at visible spectrum using the extended Cauchy model. The open triangles are the average refractive index calculated by the extrapolated n_e and n_o , respectively. The solid curves are the fitting using Eqs. (10) and (11).

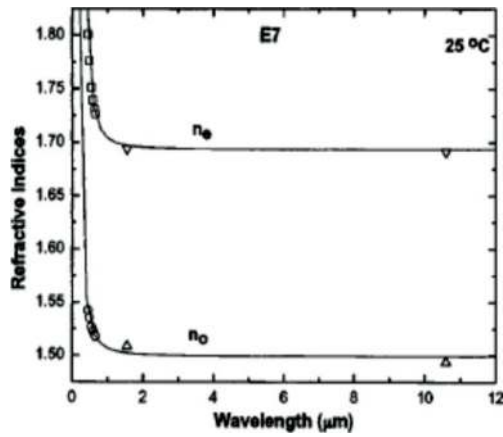

Figure 6. Wavelength-dependent refractive indices of E7 at $T = 25^\circ\text{C}$. The open squares and circles are the n_e and n_o of E7 measured at the visible spectrum. The solid curves are the fittings to the experimental data measured at the visible spectrum using the extended Cauchy model. The downward and upward triangles are n_e and n_o of E7 measured at $T = 25^\circ\text{C}$ and $\lambda = 1.55$ and $10.6 \mu\text{m}$, respectively.

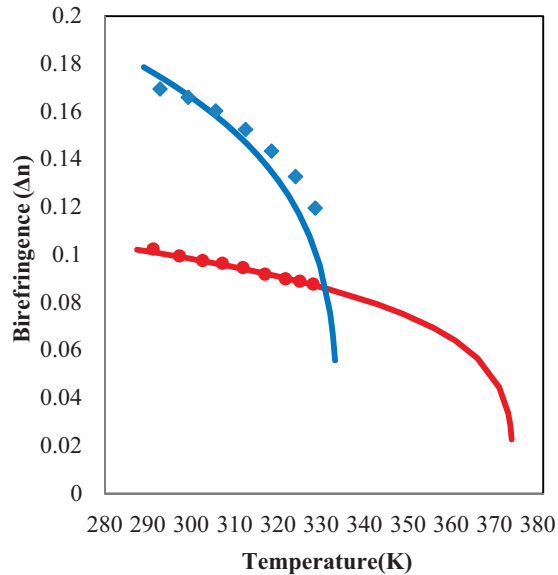

Figure 7. Temperature-dependent birefringence of E7 and MLC 6241-000 at $\lambda = 1550 \text{ nm}$, blue squares and red circles represent the birefringence of E7 and MLC 6241-000, respectively. Solid lines are fitting results using Eq. (7).

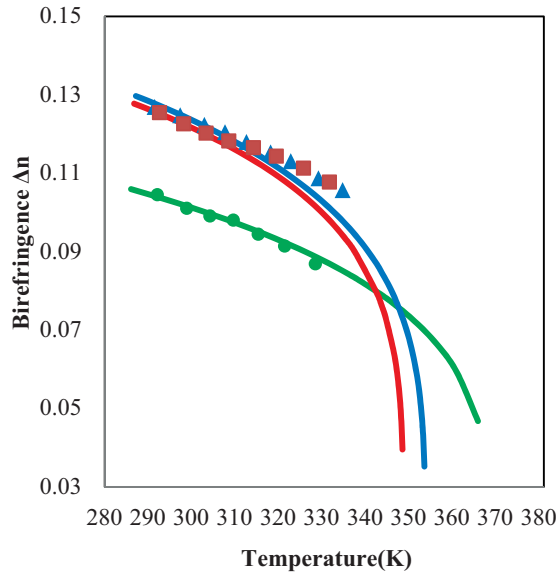

Figure 8. Temperature-dependent birefringence of three mixture samples at $\lambda = 1550$ nm. Red squares, blue triangles, and green circles represent the birefringence LCs (75% E7 with 25% MLC 6241-000, 50% E7 with 50% MLC 6241-000, and 25% E7 with 75% MLC 6241-000), respectively. Solid lines are fitting results using Eq. (7).

The temperature-dependent average refractive index of five liquid crystal samples is shown in **Figure 9**. Green triangles, red squares, black circles, brown stars, and blue monoclinic represent the average refractive index LCs of E7, 75% E7 with 25% MLC 6241-000, 50% E7 with 50% MLC 6241-000, and 25% E7 with 75% MLC 6241-000, and MLC 6241-000, respectively, while solid lines are fitting results using the four-parameter model (Eq. (9)). The fitting parameters A and B for these five samples are listed in **Table 2**. Average refractive index decreases linearly as the temperature increases.

4.2. Temperature gradient of refractive index

For practical applications, it is necessary to operate the LC device at room temperature. So, LC should be designed with crossover temperature (T_c) lower than 300 K to obtain a positive dn_o/dT at room temperature. The temperature dependence of $-dn_o/dt$ and dn_o/dt for liquid crystal can be found using Eqs. (12) and (13). These are shown in **Figure 10a–e**. The calculated values of crossover temperatures for LCs (E7, MLC 6241-000, 25% E7 with 75% MLC 6241-000, 50% E7 with 50% MLC 6241-000, and 75% E7 with 25% MLC 6241-000) are ~ 311.1 , 360.54, 354.61, 335.8, and 333.56 K, respectively. Negative temperature gradient ($-dn_o/dt$) positive for all LC samples, that means the extraordinary refractive index decreases with increase in temperature, whereas the positive temperature gradient (dn_o/dt) changes its sign from negative to positive value. The dn_o/dt is negative when the temperature is below T_c , whereas it becomes positive when the temperature is above T_c . To achieve a high dn_o/dT , high birefringence and low clearing temperature are two important factors for this.

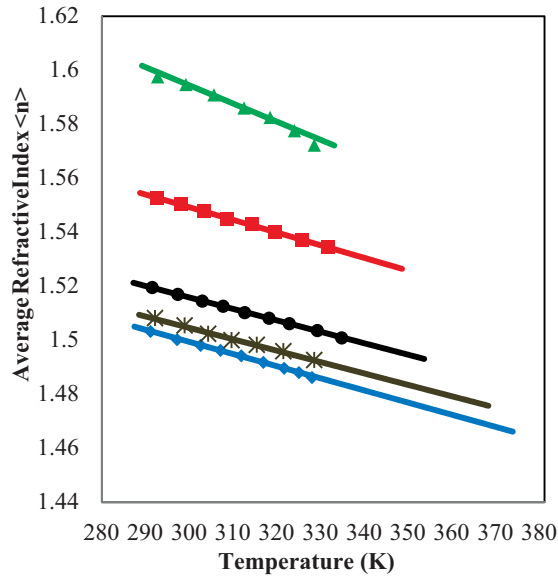

Figure 9. Temperature-dependent average refractive index $\langle n \rangle$ of five LCs at 1550 nm. Green triangles, red squares, black circles, brown stars, and blue triangles represent the average refractive index LCs of E7, 75% E7 with 25% MLC 6241-000, 50% E7 with 50% MLC 6241-000, and 25% E7 with 75% MLC 6241-000, and MLC 6241-000, respectively. Solid lines are fitting results using Eq. (9).

4.3. Studying bistability based on temperature

The refractive indices of the five liquid crystal samples were measured at $\lambda = 1550$ nm in the temperature range from 290 to 330 K. **Figure 11a–e** shows the temperature-dependent extraordinary refractive index of E7, MLC 6241-000, and three mixture samples (25% E7 with 75% MLC 6241-000, 75% E7 with 25% MLC 6241-000, and 50% E7 with 50% MLC 6241-000), respectively. From these figures, the bistability of LCs due to temperature for extraordinary refractive index is clearly observed. In the case of mixture (50% E7 with 50% MLC 6241-000), the two curves of increasing and decreasing liquid crystal's temperature intersect at 310 K to be equal until they reach to 291 K as shown in **Figure 11e**.

Figure 12a–e shows the temperature dependent ordinary refractive index of E7, MLC 6241-000, and three mixture samples (25% E7 with 75% MLC 6241-000, 75% E7 with 25% MLC 6241-000, and 50% E7 with 50% MLC 6241-000), respectively. Also, from these figures the bistability of LCs due to temperature is clearly observed for ordinary refractive index. As shown in **Figure 12e**, for mixture (50% E7 with 50% MLC 6241-000), the values of ordinary refractive index in the case of decreasing temperature become larger than its values in the case of increasing temperature case after the intersect point at 310 K.

Figure 13a–e shows the birefringence bistability of the five liquid crystal samples. The bistability is represented by the area between the temperature refractive indices and birefringence (increasing and decreasing). The measured areas are listed in **Table 3**.

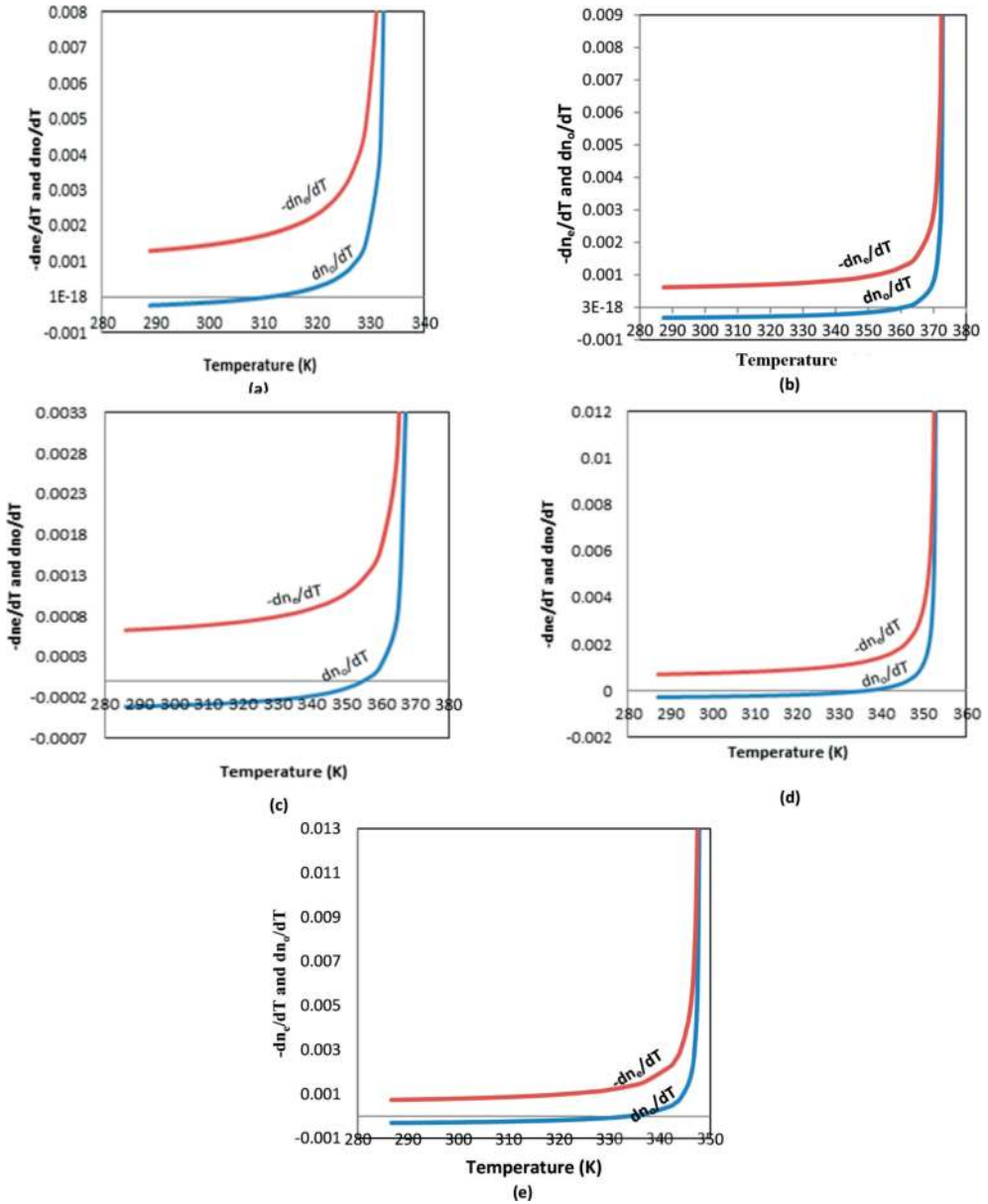

Figure 10. Temperature gradient for n_e and n_o of LC samples (a) E7, (b) MLC 6241-000, (c) 25% E7 with 75% MLC 6241-000, (d) 50% E7 with 50% MLC 6241-000, and (e) 75% E7 with 25% MLC 6241-000 at 1550 nm. Blue and red solid lines represent the calculated dn_o/dT and $-dn_e/dT$, respectively. The crossover temperature for these samples are around 311.2, 360.6, 354.7, 335.9, and 333.6 K for E7, MLC 6241-000, 25% E7 with 75% MLC 6241-000, 50% E7 with 50% MLC 6241-000, and 75% E7 with 25% MLC 6241-000, respectively.

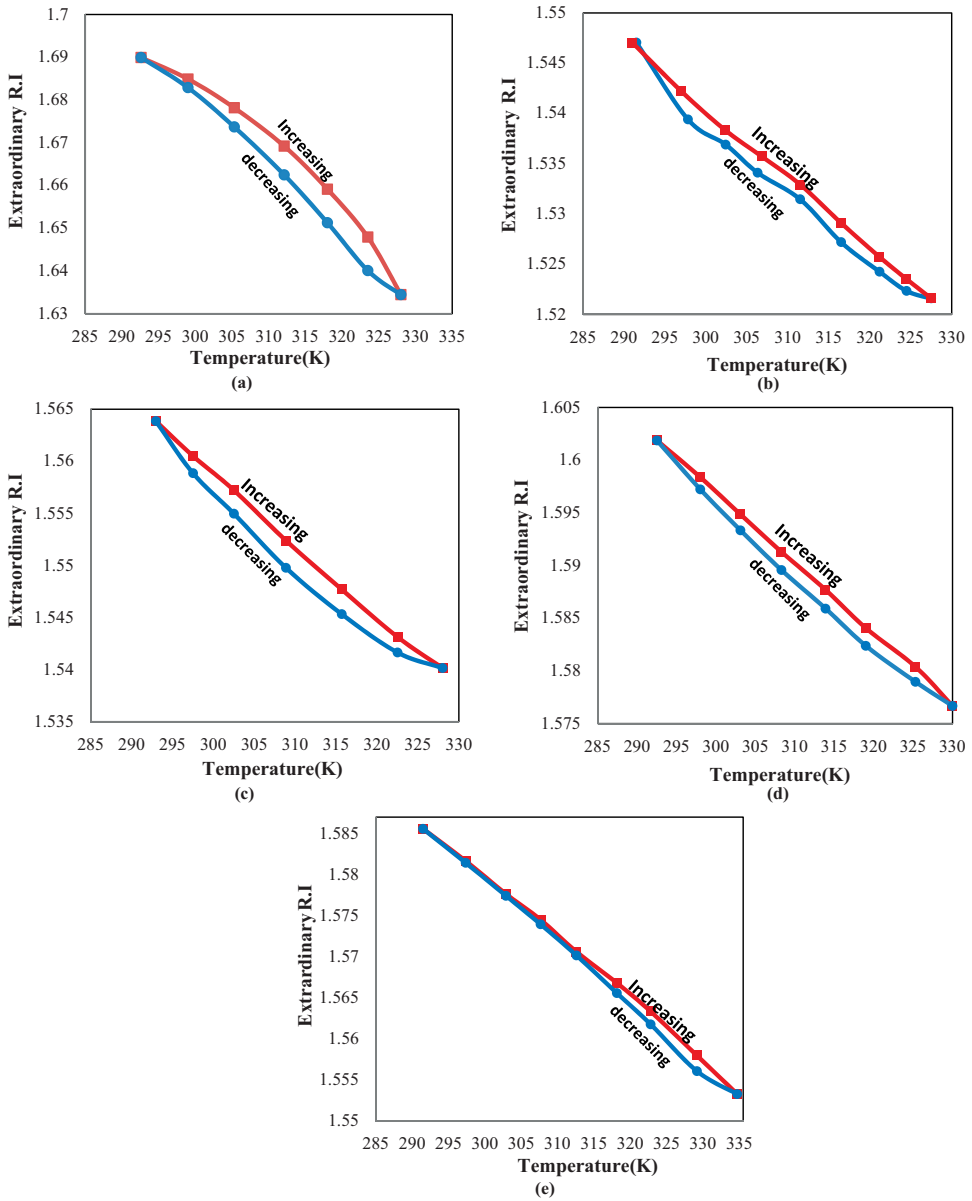

Figure 11. Temperature dependent extraordinary refractive index of (a) E7, (b) MLC 6241-000, (c) 25% E7 with 75% MLC 6241-000, (d) 75% E7 with 25% MLC 6241-000, and (e) 50% E7 with 50% MLC 6241-000, at 1550 nm. Squares and circles represent extraordinary refractive index for increasing (red line) and decreasing (blue line) temperature, respectively.

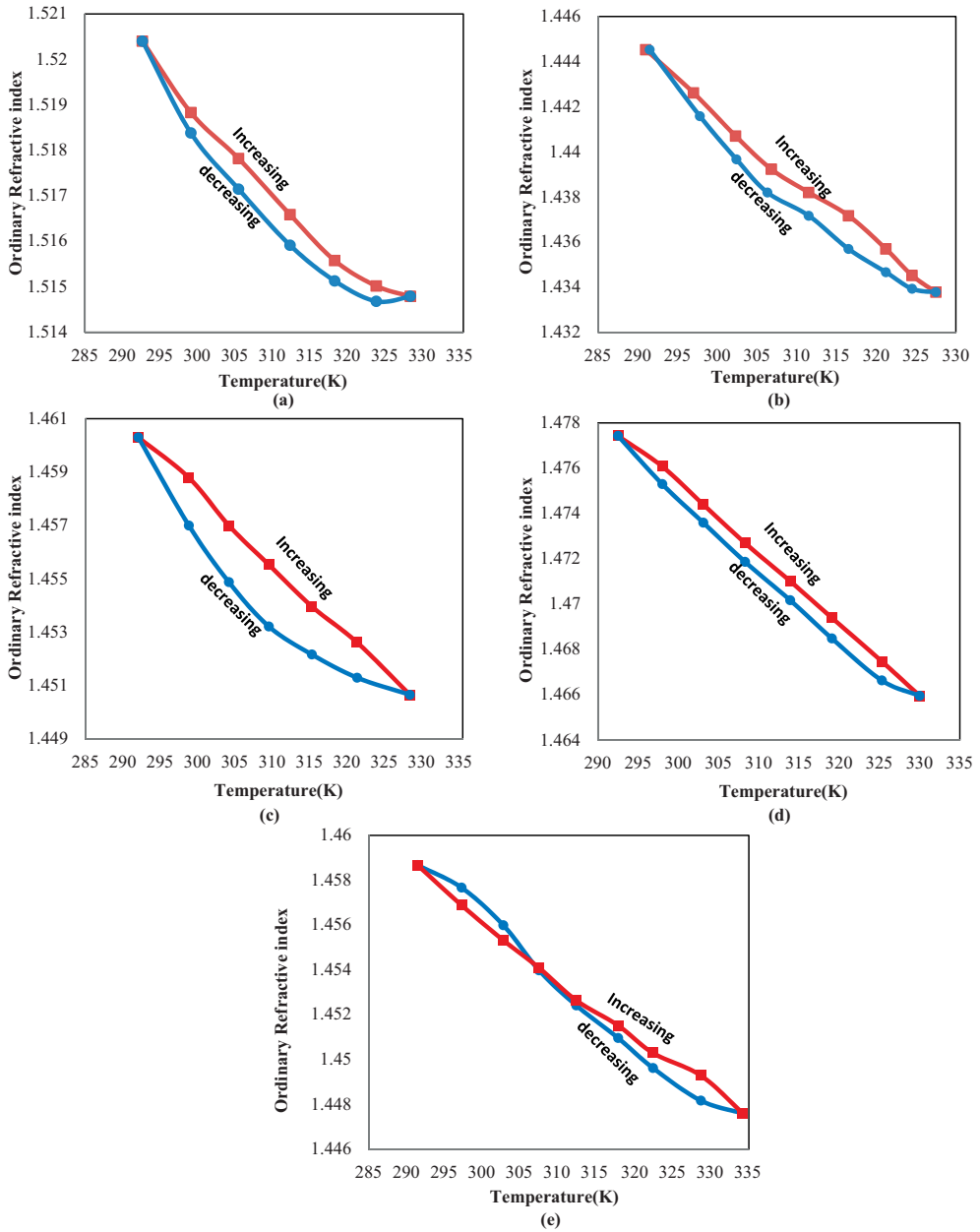

Figure 12. Temperature-dependent ordinary refractive index of (a) E7, (b) MLC 6241-000, (c) 25% E7 with 75% MLC 6241-000, (d) 75% E7 with 25% MLC 6241-000 and (e) 50% E7 with 50% MLC 6241-000 at 1550 nm. Squares and circles represent ordinary refractive index for increasing (red line) and decreasing (blue line) temperature respectively.

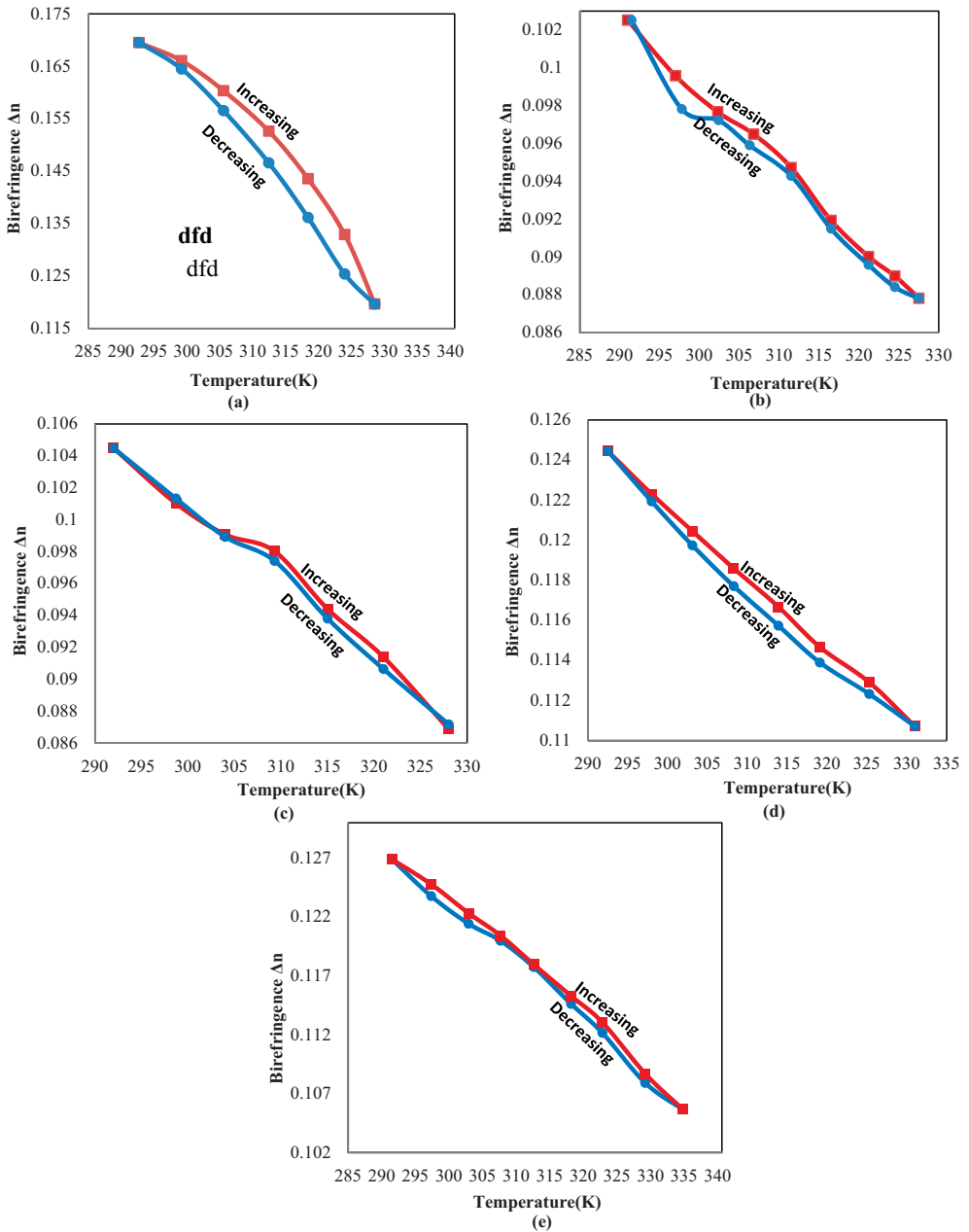

Figure 13. Temperature-dependent birefringence (Δn) of (a) E7, (b) MLC 6241-000, (c) 25% E7 with 75% MLC 6241-000, (d) 75% E7 with 25% MLC 6241-000, and (e) 50% E7 with 50% MLC 6241-000 at 1550 nm. Squares and circles represent birefringence refractive index for increasing and decreasing temperature.

Sample	Area		
	Extraordinary R.I	Ordinary R.I	Birefringence
E7	0.16882	0.01577	0.15304
25% E7 with 75% MLC 6241-000	0.06328	0.05379	0.00599
50% E7 with 50% MLC 6241-000	0.03333	0.00693	0.0264
75% E7 with 25% MLC 6241-000	0.05007	0.02704	0.02303
MLC 6241-000	0.05643	0.0337	0.02272

Table 3. The area between increasing and decreasing temperature curves of liquid crystal samples.

From these measurements, the extraordinary refractive index has larger bistability than the ordinary refractive index.

5. Conclusions

The ordinary and extraordinary refractive indices of five types of liquid crystals were measured at near-infrared region (1550 nm) and in temperature range from 290 to 330 K, using a wedged cell refractometer method. The variation in refractive indices, and average refractive index were fitted theoretically using a modified four-parameter model. Excellent agreement between the experimental data and fitted values by using four-parameter model is obtained. In addition, the birefringence of liquid crystal as a function of the temperature is calculated; high birefringence is obtained when the mixing is 50% E7 with 50% MLC 6241-000. The temperature gradients of liquid crystal refractive indices are presented; high birefringence and low clearing temperature are two important factors to achieve large dn_o/dT . The bistability of LCs due to temperature is also studied. The liquid crystal bistability based on the temperature is clearly observed for all samples. Also, the extraordinary refractive index has larger bistability than the ordinary refractive index.

Author details

Lamees Abdulkaem Al-Qurainy^{1*} and Kais A.M. Al Naimee^{1,2}

*Address all correspondence to: lamees.alqurainy@ino.it

1 Physics Department, College of Science, University of Baghdad, Bagdad, Iraq

2 C.N.R. Istituto Nazionale di Ottica Applicata, Firenze, Italy

References

- [1] Wu ST, Yang DK. Reflective Liquid Crystal Displays. New York: Wiley; 2001
- [2] Abuleil MJ, Abdulhalim I. Birefringence measurement using rotating analyzer approach and quadrature cross points. *Optical Society of America*. 2014;**53**:2097-2104
- [3] Wu ST, Hsu CS, Chuang YY. Room temperature Bis-tolane liquid crystals. *Japanese Journal of Applied Physics*. 1999;**38**
- [4] Yang CSh, Lin ChJ, Pan RP, Que CT, Yamamoto K, Tani M, Pan CL. The complex refractive indices of the liquid crystal mixture E7 in the Terhertz frequency range. *Optical Society of America*. 2010;**27**
- [5] McManamon PF, Dorschner TA, Corkum DL, Friedman LJ, Hobbs DS, Holz M, Liberman S, Nguyen HQ, Resler DP, Sharp RC, Watson EA. Optical phased Array technology. *Proceedings of IEEE*. 1996;**84**
- [6] Scharf T. Polarized Light in Liquid Crystals and Polymers. John Wiley and Sons, Inc.; 2007
- [7] Durbin SD, Arakelian SM, Cheung MM, Shen YR. Highly nonlinear optical effects in liquid crystals. *Journal of Physique*. 1983;**44**:161-169
- [8] Thingujam KD, Sarkar SD, Choudhury B, Bhattacharjee A. Effect of temperature on the refractive indices of liquid crystals and validation of a modified four-parameter model. *Acta Physica Polonica A*. 2012;**122**
- [9] Abdulkareem L, Abdalah SF, Al Naimee K, Meucci R. Temperature effect on nonlinear refractive indices of liquid crystals in visible and NIR. *Optics Communications*. 2016;**363**:188-194
- [10] Horn RG. Refractive indices and order parameters of two liquid crystals. *Journal of Physics*. 1978;**39**:105-109
- [11] Wu ST. A Semiempirical model for liquid crystal refractive index dispersions. *Journal of Applied Physics*. 1991;**69**:2080-2087
- [12] Li J, Guaze S, Wu ST. Temperature effect on liquid crystal refractive indices. *Journal of Applied Physics*. 2004;**96**:19-24
- [13] Li J, Wu ST, Brugioni S, Meucci R, Faetti S. Infrared refractive indices of liquid crystals. *Journal of Applied Physics*. 2005;**97**
- [14] Blinov LM. Structure and Properties of Liquid Crystals. Springer; 2011
- [15] Yang DK, Wu ST. Fundamentals of Liquid Crystal Devices. Wiley and Sons, Ltd.; 2006
- [16] Li J, Wu ST. Extended Cauchy equations for the refractive indices of liquid crystals. *Journal of Applied Physics*. 2004;**95**

- [17] Thingujam KD, Sarkar SD, Choudhury B, Bhattacharjee A. Effect of temperature on the refractive indices of liquid crystals and validation of a modified four- parameter model. *Acta Physica Polonica A*. 2012;**122**:754-757
- [18] Li J, Guaza S, Wu ST. High dno/dT liquid crystals and their applications in a thermally tunable liquid crystal photonic crystal fiber. *Molecular Crystals and Liquid Crystals*. 2006;**453**:355-370
- [19] Guaza S, Li J, Wu ST, Spadlo A, Dabrowski R, Tzeng Y, Cheng K. High birefringence and high resistivity Isothiocyanate-based Nematic liquid crystal mixtures. *Liquid Crystals*. 2005;**32**:1077-1085
- [20] Li J, Gauzia S, Wu ST. High temperature-gradient refractive index liquid crystals. *OSA*. 2004;**12**
- [21] Yang CSh, Lin ChJ, Pan RP, Que CT, Yamamoto K, Tani M, Pan CL. The complex refractive indices of the liquid crystal mixture E7 in the Terhertz frequency range. *Optical Society of America*. 2010;**27**
- [22] Li J, Wen CH, Lu R, Wu ST. Refractive indices of liquid crystals for display applications. *Journal of Display Technology*. 2005;**1**
- [23] Kumar A. Calculation of optical parameters of liquid crystals. *Acta Physica Polonica A*. 2007;**112**
- [24] Ozbek H, Ustunel S, Kutlu E, Cetinkaya MC. A simple method to determine high-accuracy refractive indices of liquid crystals and the temperature behavior of the related optical parameters via high-resolution birefringence data. *Journal of Molecular Liquids*. 2014;**199**:275-286
- [25] Brugioni S, Meucci R, Faetti S. Refractive indices of liquid crystals E7 and K15 in the mid- and near-IR regions. *Opticheskii Zhurnal*. 2006;**73**:15-17