

## Chapter

# Cryobiology and Cryopreservation of Sperm

*Ali Erdem Öztürk, Mustafa Numan Bucak, Mustafa Bodu,  
Nuri Başpınar, İlhami Çelik, Zhiquan Shu,  
Nazan Keskin and Dayong Gao*

## Abstract

Low temperature has been utilized to keep living cells and tissues dormant but potentially alive for cryopreservation and biobanking with great impacts on scientific and biomedical applications. However, there is a critical contradiction between the purpose of the cryopreservation and experimental findings: the cryopreserved cells and tissues can be fatally damaged by the cryopreservation process itself. Contrary to popular belief, the challenge to the life of living cells and tissues during the cryopreservation is not their ability to endure storage at cryogenic temperatures (below  $-190^{\circ}\text{C}$ ); rather it is the lethality associated with mass and energy transport within an intermediate zone of low temperature ( $-15$  to  $-130^{\circ}\text{C}$ ) that a cell must traverse twice, once during cooling and once during warming. This chapter will focus on (1) the mechanisms of cryoinjury and cryoprotection of human sperm in cryopreservation, and (2) cryopreservation techniques and methods developed based on the understanding of the above mechanisms.

**Keywords:** cryopreservation, cryobiological characteristics, sperm

## 1. Introduction

The pioneering studies in cryobiological science starting from the middle of the last century is based on the idea that whether life span and longevity could be extended by storing various frozen tissues and organs or even human body for many years. Possible cellular and tissue destruction during the freeze-thaw processes became the subject of curiosity.

The male reproductive cell, spermatozoon, was first discovered in 1677 by Van Leeuwenhoek and was called “Animalacula.” The early studies to obtain pregnancy by artificial insemination were done by Lazzaro Spallanzani in 1776 [1, 2]. The studies with scientific basis and modern vital cell freezing studies began in 1949 after the discovery of glycerol as a cryoprotectant by Polge et al. [3] and spermatozoon became the first mammalian cell to be successfully frozen [4]. Following the success in freezing spermatozoa, Whittingham et al. [5] successfully froze the mouse embryo by using dimethylsulfoxide (DMSO) as a cryoprotectant, in 1972. Nowadays, millions of children have been born from cryopreserved sperms or embryos.

Sperm cryopreservation has been successfully applied in various fields to benefit the human kind and animals, including assisted reproduction, rescuing the endangered species, and saving the ecosystem. However, we also know that damage

can be caused to the cells during the cryopreservation process. In this review, the mechanisms of damage to the sperm cells during the process of cryopreservation will be taken under spotlight and we will try to elucidate them in a cause-effect manner.

## **2. What is cryobiology?**

Cryobiology is a multidisciplinary science, studying the physical and biological behaviors of living materials (e.g., cells and tissues) at low temperatures. Cryobiology contains many disciplines such as, cellular biology, theriogenology and molecular biology, engineering and mathematics, veterinary and human medicine, intensive and extensive farming on land and in watery environments [6]. Optimization of the cryopreservation procedure of spermatozoa needs all the above-mentioned disciplines because of the complex cellular structure, activation and capacitation mechanisms of spermatozoon [7].

## **3. Dormant or dead? two aspects of freezing of cells**

Freezing biological time occurs when the cells are cooled down in controlled manner under temperatures lower than necessary for continuing their normal physiological activities. Damaged or dying cells exhibit characteristic changes that cause structural differentiation under destruction process and are dragged into a possible death. In the present case, there are two types of scenarios, where cells may be damaged or killed: necrosis and apoptosis.

### **3.1 Necrosis**

The cell death takes place through one of the pathways such as necrosis, necrobiosis, or apoptosis. In necrosis, a pathological cell death, the cell has been severely damaged as a result of sudden and extreme trauma, and soon death occurs. Because the cell loses control of permeability of plasmalemma, the cytosol rapidly swells by excessive inflow of water and ions, and organelle becomes excessively swollen. As a result, the cell lyses without spending energy. The cell contents and endotoxins leak out of the collapsed or inflammatory cells into the area where inflammatory changes begin. In this case, neighboring cells and tissue elements may also be exposed to damage as well [8]. Factors causing damage by disrupting the local homeostatic balance of the cells and tissues such as hypoxia, viral, and bacterial infections, toxins, radiation and changes in temperature are the main causes of necrosis. Necrosis, as an irreversible process, is also defined as a transition of cell into a definite death and loss of all of its physiological functions.

### **3.2 Apoptosis**

Apoptosis, which is a programmed cell death differs from necrosis with a variety of morphological, biochemical, and physical changes.

Essentially, apoptosis is a physiological cell death, a natural process that occurs during embryonic development and periodically in organs such as mammary gland and uterus, which undergo cyclic changes. In this case, the cell systematically ceases all of its functions and breaks down by incorporating its structural components into vesicles [9]. The main histological differences between apoptosis and necrosis are summarized in **Table 1**.

Cellular results	Necrosis	Apoptosis
General cellular changes	The cell is swollen, massive cell death occurs in a very large area.	Cells die in groups, apoptotic bodies are formed.
Organelles	Damaged	Not damaged
Mitochondria	Mitochondria, due to lack of ATP swell and break down	Mitochondria are swollen, cytochrome-C is released.
Cell membrane	There is structural deterioration, selective permeability control is lost.	It is intact, the surface takes a crater appearance, vesicles are formed.
Nucleus	Chromatin loses its normal organization and is in the form of thick chromatin yarns. Pyknosis, karyorrhexis, or karyolysis develops.	Chromatin is fragmented, it is concentrated in the form of a hat, nucleolus is dispersed
Causal factors	Anoxia, starving, physical and chemical traumas that lead to ATP deficiency.	They are physiological and pathological conditions that do not lead to ATP deficiency.
Effects on the tissue	The inflammatory events develop, degenerated cell debris is found in the environment and these are engulfed by phagocytes. There is a common tissue destruction.	There is no inflammation, the resulting apoptotic vesicles are phagocytosed by neighboring cells and macrophages, a rapid involution occurs without collapse in the tissue.

**Table 1.**  
*Comparison of the effects of necrosis and apoptosis on cells, organelles, and tissues [10, 11].*

Apoptosis consists of three stages as, final decision, execution, and cleaning phase. The cell receives a nonreversible lethal apoptotic stimulation beyond the time of decision. In the execution phase, condensation of chromatin in the cell, shrinking of the cytoplasm, formation of buds in the cell membrane, fragmentation of DNA, and formation of apoptotic bodies occur.

These changes are affected by different enzymes such as proteases, lipases, and nucleases. In the final stage of the cleaning process, apoptotic bodies are phagocytosed by macrophages [tingible body macrophages (TBM)] or neighboring cells [9]. The main difference between the consequences of apoptosis and necrosis is that the apoptotic cell never leaks the cytoplasmic contents into the extracellular space and destroys the genetic content before phagocytosis. All these events are of great importance in the removal of cytotoxic T lymphocytes containing virus-infected cells and activated harmful granules. In this respect, apoptosis is a clean way of cell death [12].

Stress factors such as heat and cold shocks, oxidative stress, ultraviolet light, and ionizing radiation trigger the activation of stress-activated protein kinases (SAPKs) such as c-Jun N-terminal kinase (JNK) and p38. JNK is an important element of the signal pathway leading to apoptosis in response to stress conditions [9, 13]. Apoptosis related to our subject arises as cold-induced apoptosis, rather than the lethal effect of long-term storage, freezing damage or cold-struck damage occurs [14]. Contrary to the assumption that very low temperatures are lethal to cells, the cells are more severely damaged at moderate temperatures between  $-15$  and  $-60^{\circ}\text{C}$ . All chemical or biological reactions are almostly ceased at the liquid nitrogen temperature ( $-196^{\circ}\text{C}$ ). The only reaction that can occur at  $-196^{\circ}\text{C}$  is the one arisen from cosmic radiation. A 200–400 rad dose of radioactivity can damage 63% of a cell population [15]. The earth is exposed to 0.1 rad cosmic radiation per year [16]. This corresponds to the amount of radiation that the frozen mammalian cell will be exposed to for 2000–4000 years at  $-196^{\circ}\text{C}$ .

Cells that are stored at temperatures above  $-80^{\circ}\text{C}$ , deteriorate over time and continue their cellular activities due to presence of solutes with different ion

concentrations in the environment that are not fully frozen. Death can occur anytime, depending on temperature, animal breed, cell type, and freezing medium [16]. For a cell, which can be stored theoretically for 4000 years at  $-196^{\circ}\text{C}$ , it can be considered that biological time has stopped [16].

#### **4. Structure of biological membranes**

All gamete cells, oocyte, and sperm, have a liquid mosaic membrane structure that are mainly composed of various phospholipids and proteins [17]. The cell membrane has at least three major tasks: to separate the cells from the external environment, to ensure that they have a specific shape, and to control the exchange of various solutes between the cell and the external environment.

The major structural components involved in the membrane structure are phospholipids, glycolipids, transmembrane proteins, peripheral proteins, and cholesterol. According to Parks et al. [18], membrane integrity is dependent on four important factors as follows:

1. Preservation of membrane integrity by bonds between the lipids to prevent lateral displacement of the lipids;
2. In order to preserve the stability of the lipids, they have to bond with the building blocks of the cell skeleton, with proteins forming a naturally occurring column;
3. The presence of large integral membrane proteins which serve to provide diffusion between the intracellular and the external environment and to stabilize intracellular balances; and
4. The presence of phospholipids and aquaporins with selective permeability in the membrane structure.

There are two layers, internal and external, formed by different types of phospholipids linked together in a chain form in the cell membrane. Positively charged phospholipids such as phosphatidylcholine and sphingomyelin tend to be present in the outer leaflet of the cell membrane, whereas anionic phospholipids such as phosphatidylethanolamine, phosphatidylserine, and phosphatidylinositol tend to be present in the inner leaflet. The interactions between these two phospholipid layers work to form the transmembrane channels by cholesterol and proteins [18]. Phospholipids, which provide fluidic and variable membrane structure and are predominant in the docosahexaenoic acid chain, constitute 65–70% of total membrane lipids [19].

In order to make a more detailed explanation of the biological membrane structure, the first necessity is to identify the phospholipid and the above-mentioned sub-groups of phospholipids.

##### **4.1 Phospholipids**

Phospholipid consists of a phosphate group, one or two fatty acid groups attaching to this group, an alcohol group, and the glycerol or sphingosine backbone linking them. Phospholipids, which form the majority of the cell membrane, also increase the resistance of the cell to cold shock. It was also found that resistance to cold shock was higher in live sperm with high phospholipid/cholesterol ratio [20].

#### 4.1.1 Phosphatidylcholine

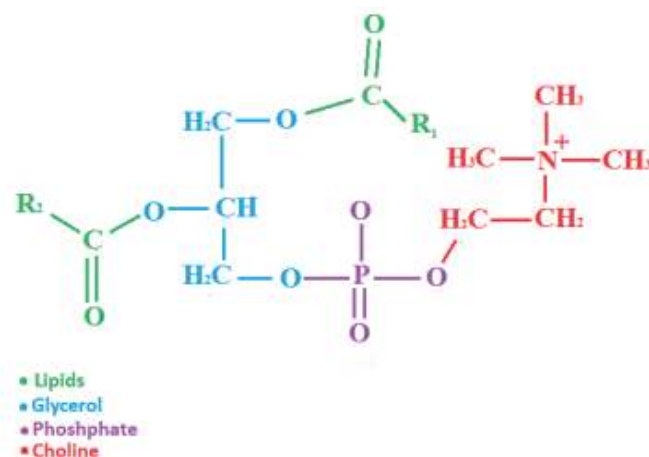
It is a membrane lipid that consists of a phosphate group, two fatty acids, and the glycerol backbone of choline. Phosphatidylcholine, also known as lecithin, is present in high amount in the membrane and plays an active role on membrane stability. Simpson et al. [21] found that phosphatidylcholine exhibited protective properties against cold shock and that phosphatidylcholine-rich spermatozoa exhibited better motility levels than the spermatozoa deprived of phosphatidylcholine [21]. Sariozkan et al. obtained a higher level of motility in the group with 5% lecithine compared to the control group for bull sperm [22] (**Figure 1**).

#### 4.1.2 Phosphatidylinositol

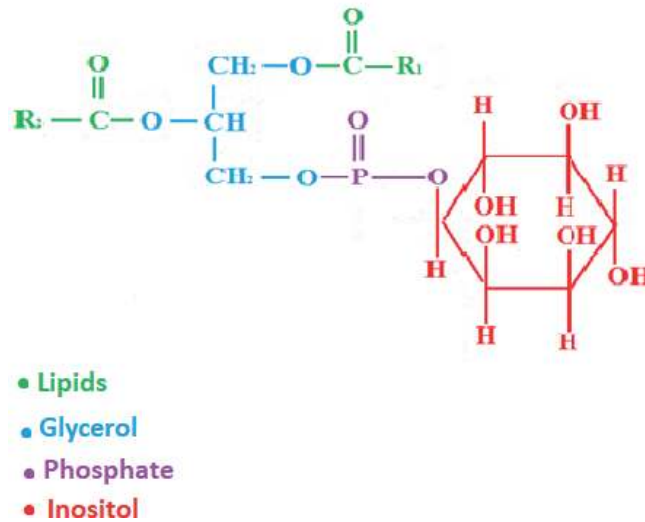
It is a membrane lipid that consists of a phosphate group, two fatty acids, and a glycerol backbone of inositol. It has functions in the growth and division of the cell, exchange of membranous materials, participating in the cytoskeleton structure and binding to the target proteins (membrane proteins) to maintain membrane stability and fulfilling their tasks [23]. Luconi et al. found that human sperm with phosphatidylinositol exhibited higher motility level [24] (**Figure 2**).

#### 4.1.3 Phosphatidylserine

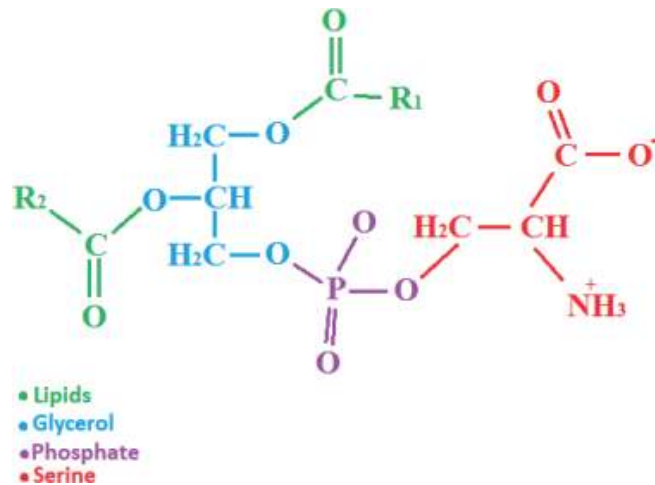
It is a membrane lipid consisting of two fatty acids and glycerol backbone of serine. It causes the start of capacitance or apoptotic changes through displacement between membrane foliage. Arrighi et al. [25] emphasized that phosphatidylserine is localized mainly in the head and middle region of a normal spermatozoon, emphasizing phosphatidylserine externalization in apoptotic spermatozoa, and 14% externally phosphatidylserine apoptotic spermatozoon in normal semen. Removing these externalized phosphatidylserine apoptotic spermatozoa from the environment, results in an increase in fertility. Wilhelm et al. [26] also investigated the effect of phosphatidylserine and cholesterol supplementation on sperm parameters after freezing/thawing, and consequently, samples with phosphatidylserine and cholesterol showed higher motility and viability than the control group (**Figure 3**).



**Figure 1.**  
Diagram of phosphatidylcholine molecule.



**Figure 2.**  
Diagram of phosphatidylinositol molecule.



**Figure 3.**  
Diagram of phosphatidylserine molecule.

#### 4.1.4 Phosphatidylethanolamine

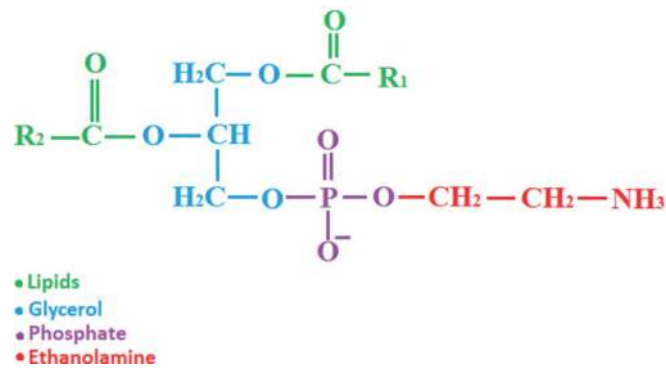
It is a class of lipids that consist of two fatty acids and a glycerol backbone of ethanolamine. It has the ability to build hydrogen bonds with other membrane proteins with its two electrons. This ability contributes to membrane integrity and plays a role in membrane reforming during phase transitions [27] (**Figure 4**).

#### 4.1.5 Sphingomyelin

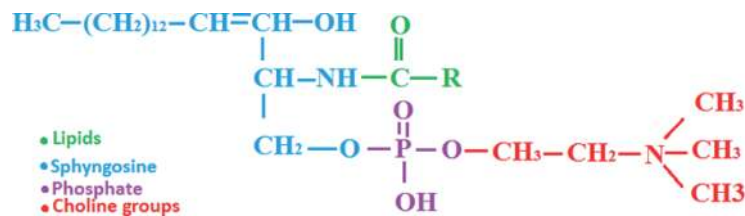
Unlike the other membrane lipids mentioned above, the backbone of sphingomyelin is formed by sphingosine (an unsaturated aminoalcohol) instead of glycerol. It is a membrane lipid consisting of a fatty acid and a sphingosine backbone of choline group (**Figure 5**).

Although phospholipids constitute the great majority of membrane structure, the most effective molecule is cholesterol that provides integrity to both the phospholipids and other components. The effect of cooling and freezing on the sperm





**Figure 4.**  
 Diagram of phosphatidylethanolamine molecule.

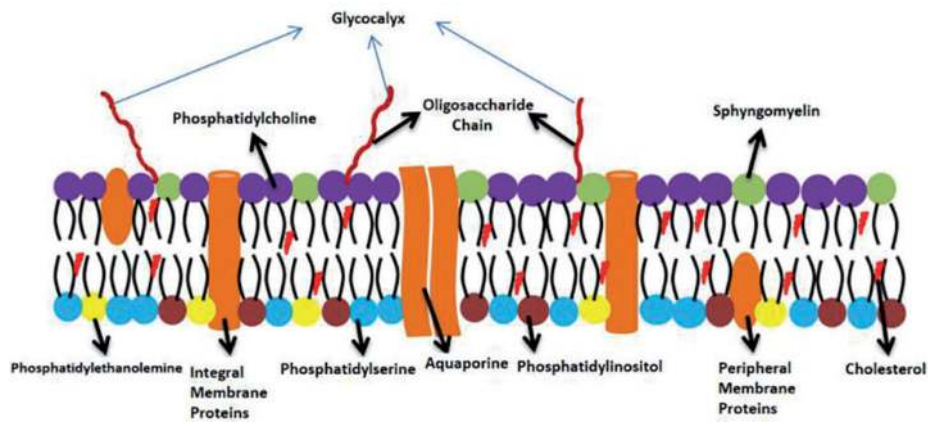


**Figure 5.**  
 Diagram of sphingomyelin molecule.

membrane is directly related to the cholesterol/phospholipid ratio in the membrane, saturation in the hydrocarbon chains (the chain formed by the addition of hydrogen bonds between the hydrogen and carbon atoms of the lipids themselves), and protein/phospholipid ratio [28]. At the same time, it was proven that cholesterol in phosphatidylcholine, phosphatidylethanolamine, and cholesterol mixtures was observed more intensely in the areas of phosphatidylcholine [29]. The cholesterol molecule is considerably smaller in size than phospholipids and therefore has the ability to move freely in the membrane. The cholesterol molecule is mostly concentrated in portions, where hydroxyl groups are rich in phospholipid ester carbonyls [30]. If cholesterol was extruded from the spermatozoon plasma membrane, there was an increase in fluidity, permeability, and fusion capacity in the membrane structure, and the structure of the membrane was damaged [31, 32]. When cholesterol was added into membrane, the membrane stability and motility increased, whereas capacitance decreased.

Cholesterol plays an effective role in the phase transitions in the membrane structure. As the cell membrane passes from the liquid crystal phase to the lamellar gel phase, the membrane cholesterol densifies the structure of the hydrocarbon chains of the fluid phospholipids and causes degradation of the lipids in the gel phase [33]. There are various proteins along with lipids on the cell membrane. Proteins, which have the functions of contributing to the membrane integrity by forming the attachment area to the lipids, and allowing the cells to exchange materials from the outside, are divided into two membrane proteins of, namely, the peripheral membrane and the integral membrane.

Peripheral membrane proteins can be found both on the exterior and interior of the cell. It has the task of forming protein-protein bonds and participating in the skeletal structure of the membrane. Integral proteins, which are another type of proteins, are opened both internally and externally of the cell and interact with both environments. It has functions, such as creating a holding place for cytoskeleton and glycoproteins, generating responses by receiving signals from various



**Figure 6.**  
A schematic representation of cell membrane components is shown.

chemical substances, and providing the exchange of substances between the inner and outer environments of the cell.

During freezing and thawing, protein channels called aquaporins (AQP) have functions to control the water inlet and outlet to the cell. Aquaporins are composed of four different monomers, which are independent of each other, in many cell types, from bacteria to plants and to mammalian cells. These four different monomers combine and form a tetramer. While each monomer is only water-permeable, the fifth channel in the middle allows passage of both water and various ions [34]. It is much faster and easier for water to pass through aquaporin channels when compared to membrane lipid. Although, there are 200 kinds of aquaporins in all living species, there are only 13 kinds of aquaporins in mammals. AQP7, AQP8, and AQP11 were identified on the spermatozoon membrane. While AQP7 is responsible for sperm glycerol metabolism, AQP8 is responsible for the water exchange of the cell. AQP11 is involved not only in the membrane structure, but also in the tail as well as in the exchange of cellular matter [35].

Cells use oligosaccharide chains (sugar chains formed by combining 2–20 monosaccharides) that extend out of the membrane as a tentacle or an arm to perceive various structures in the extracellular environment, interact with other cells, and initiate the necessary physicochemical reactions. These sugar chains are termed glycolipid chains when derived from lipids and glycoprotein chains when derived from proteins. These glycolipids and glycoprotein chains extend outward to bring a network-like structure around the cells. This network-like structure is called glycocalyx (**Figure 6**).

#### 4.2 Damage and phase changes in the membrane structure

The cell membrane is a fluidic mosaic structure with cholesterol, integral and peripheral proteins, lipids, and many more.

There are many different types of phospholipids in the cell membrane. The changes that occur during freezing-thawing also originate from the structural differences in these phospholipids. The main factor that drives the structural differences is the dimensional changes between the head part forming the phospholipids and the acyl chains. These dimensional changes directly affect the various changes in the membrane structure at the later stage as well as lipids depending on the lipid type.

If in a phospholipid, the head and acyl chains are similar or identical in size, the phospholipid molecule is in a cylindrical form. Phosphatidylcholine is an example for this kind of phospholipids. This kind of phospholipids is termed as



bilayer lipids and are not significantly affected by phase changes during cell cooling. In the homogeneous phospholipid distribution that occurs during the phase change, these types of phospholipids in the form of bilayers are gathered together to form the bilayer membrane model; in other words, they continue to create the lamellar phase of the liquid crystal. If in a phospholipid the head and acyl chain are in different sizes, the phospholipid is in an inverted or flat cone-like form. This kind of phospholipids is called non-bilayer form phospholipids. Phosphatidylethanolamine is as an example for this type of lipids.

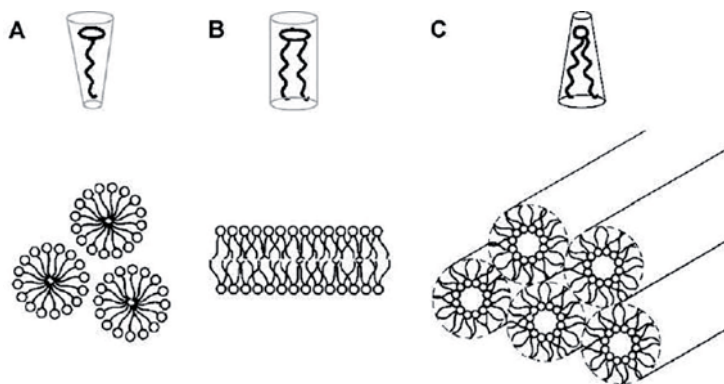
When the cell starts to cool down, the non-bilayer form of phospholipids undergoes a phase transition from the liquid crystal phase to the gel phase [36]. If the head and acyl chains are of different sizes in a phospholipid, this kind of lipids are also called non-bilayer lipids. During the phase changes, the non-bilayer lipids in the aggregate come together to bring up the different structures, which will be mentioned in the next section. Non-bilayer form phospholipids mainly consist of 2 types of phospholipids:

*Type 1:* Polar (+charged, hydrophilic) head in type 1 non-bilayer phospholipids is larger than apolar (–charged, nonpolar) tail. For this reason, they are in the form of an inverted cone. When the membrane is cooled, the negatively charged heads are directed outward and the neutral apolar parts are inwardly arranged to form micelle-like structures depending on temperature changes [37].

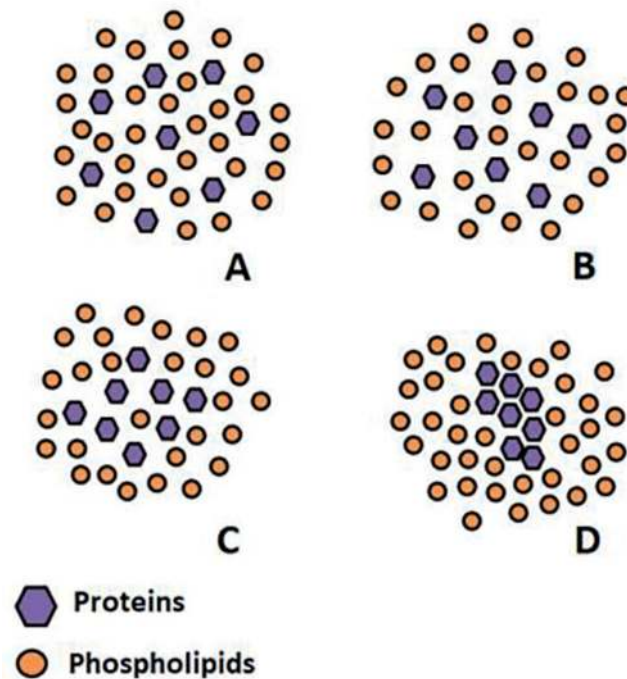
*Type 2:* For polarity of type 2 form phospholipids, the polar head is smaller than the apolar tail. For this reason, they are in the form of a flat cone, and when temperature changes, the negatively charged head part is arranged in the apolar neutral part outwardly and called hexagonal II ( $H_{II}$ ) [38] (**Figure 7**).

Non-bilayer lipids are distributed heterogeneously on the cell membrane and carry out some vital tasks for the cell, including:

1. providing membrane flexibility,
2. participating in the barrier activity against the outer environment,
3. protecting their stability by binding to the membrane's peripheral proteins through creating a surface to attach to the proteins, and
4. building the structures that integral proteins can hold, etc.



**Figure 7.** This schematic representation depicts phospholipid-shaped non-bilayer type 1 lipids as indicated by the letter A and they are schematized at the bottom just below. In B, bilayer form phospholipid is schematized and bifilar lamellar form with a normally arranged phospholipid model was also depicted in the case where the cells were not subjected to heating or cooling (at a 36°C temperature). In C, non-bilayer type 2 lipids and hexagonal form II formulated due to heat exchange are schematized [37].



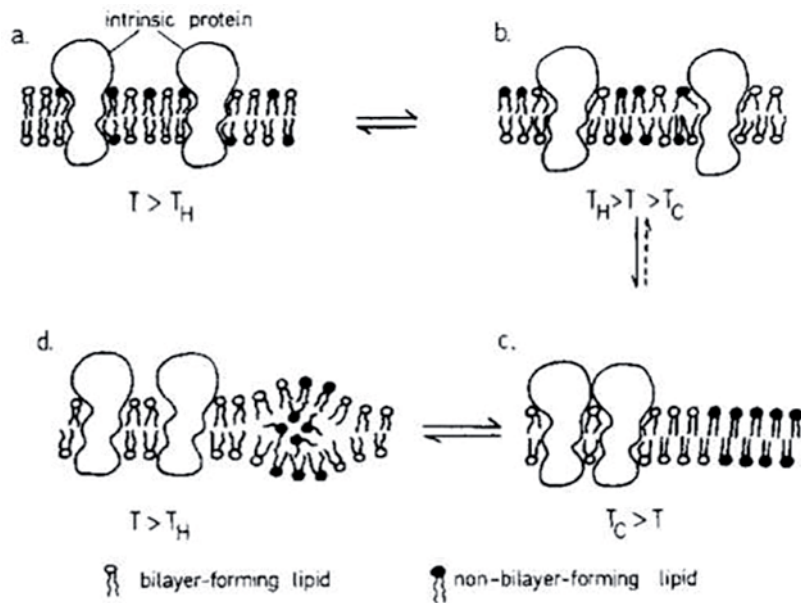
**Figure 8.**

*In this schematic, the effect of cooling on the cell membrane structures is shown. The phospholipid-protein components, which are in a heterogeneous structure starting from A, show clusterings due to cooling (B, C) as mentioned above, and membrane proteins appear to be tight in the center while phospholipids appear to be like honey pellets in the last stage (D).*

Membrane phospholipids enter a phase transition generally between 36 and 5°C. These phase changes are species-specific and cause different responses to temperature changes depending on the animal's spermatozoa. When cell cooling starts, some phospholipids in the membrane structure undergo phase changes. The phospholipids in the non-bilayer form are bound to each other by hydrocarbon-chain bonds. As the hydrocarbon chains undergo crystallization and hardening, the lipids passing through the hexagonal Form II become more tightly bonded to each other, and the membrane proteins weakly bound to phospholipids cause aggregation on the membrane. They are tightly agglomerated to occupy less space than normal (**Figure 8**).

The phospholipids that are interlocked with the proteins and hydrocarbon bonds that come together due to phase changes during cooling of the cells are in the nonlamellar phase at  $-196^{\circ}\text{C}$ . However, during thawing, proteins and phospholipids do not return to their original situations. In this process, the membrane in the form of non-bilayer phospholipids came together and converted into the structures in the form of phospholipid micelles and hexagonal Form II. However, during thawing, these phospholipids cannot recombine to form bilayer phospholipids and turn into a fluidic mosaic membrane structure; therefore, the membrane structure has permanently been damaged (**Figure 9**). In this case, the non-bilayer phospholipids interacting with proteins are separated from the proteins and converted into a homogeneous form, different from the mosaic form.

Since proteins and various phospholipids are arranged in a heterogeneous structure in the normal arrangement of cells, exchange of substances is achieved in almost every region of the cell membrane. When the membrane structure is deteriorated in this way, substance exchange occurs especially where protein aggregation is intense. In this case, the non-bilayer phospholipids in specific interactions with proteins are separated from proteins and transformed from fluidic mosaic to homogeneous form [40].



**Figure 9.** Bilayer and non-bilayer phospholipid interactions during cooling and after re-thaw process [39]. The figure shows the phase separations in biological membranes associated with cooling biological membranes from their growth temperature (a) to a temperature below the gel (b) to liquid-crystalline phase-transition temperature (c) and reheating to the growth temperature (d). Lipids that tend to form hexagonal-II phase are indicated by a solid head group.

Proteins are one of the basic building blocks of the cell and carry out many functions in the cell metabolism. Hydrogen bonds in the water molecules play a very important role in the denaturation of proteins. In the hydrophobic polar (HP) protein model, amino acids are reduced to polar (represented by P, charge or dipole) or nonpolar (H) point entities. Hydrophobicity is defined as the desire to reduce surface area of proteins that are interacting with water, and is related to the conversion of neighboring molecules into a similar energy-attractive structure. The hydrophobic molecules in the solution produce a more energetically favorable structure compared to the water bodies by forming ice-like cages in their surroundings at low temperatures. The cell systematically tries to reduce the energy by increasing the number of cages. This is the cold denaturation of proteins [41]. On the opposite side, at higher temperatures, water molecules do not form cages. Irregular water molecules around the hydrophobic amino acids in proteins are energetically less advantageous than the water bodies. Thus, the proteins try to hide their hydrophobic parts in the building blocks. Biological structures, especially proteins, undergo structural changes during temperature changes. For this reason, nucleic acids and many polysaccharides need to stay in a certain temperature range with specific ionic strength and pH value to fulfill their functions. Cold protein denaturation occurs at a temperature range of 0 to  $-20^{\circ}\text{C}$ , reversibly or irreversibly, but mostly irreversibly. Globular proteins often undergo partially reversible denaturation. During denaturation, the covalent bonds between the atoms forming the peptide bonds between the amino acids of the proteins are not broken, but only hydrogen bonds change their structure. Protein denaturation during freezing or thawing leads to protease leaks from liposomes presenting in the acrosome and loss of membrane integrity.

## 5. Cryoprotective agents (CPA)

Prior to the discovery of cryoprotective agents, some successful cooling protocols relied on extracellular ice formation suppression and sustaining cell viability

by various chemical agents [7]. Mammalian cells had not been successfully cryopreserved until 1949 by Polge, Smith, and Parkes when glycerol was accidentally found to have protective functions in freezing cells [3]. It has also been observed that if the correct dose of cryoprotectant is used and the cells are cooled down at the optimal cooling rate, the survival potency of cells is increased [42].

Cryoprotectants are used to avoid or decrease the cold shock damage and intracellular ice formation during freezing, recrystallization during thawing, and membrane destabilization. Cryoprotectants can reduce the freezing point and the proportion of salts and solutes in the sample by increasing the amount of liquid fraction, and suppress ice formation both outside and inside of the cells [43]. In biological structures, while the hydrogen bonds between the membrane phospholipids are connected by the oxygen atoms contained in the water molecules, the cryoprotecting substances such as glycerol are replaced by water. These bonds have utmost importance for membrane integrity [44]. It has been reported that supplementation of 0.2 M sucrose or trehalose into bull semen during freezing and thawing increases sperm viability [45]. A good cryoprotectant should be water-soluble and have minimal toxic effects [46].

Cryoprotectants can be divided into two groups according to their mechanism of action, as penetrating and non-penetrating cryoprotectants.

### **5.1 Penetrating cryoprotectants**

Penetrating cryoprotectants have low molecular weight and therefore they have the ability to enter the cells. In this way, they can affect both intracellular and extracellular environments.

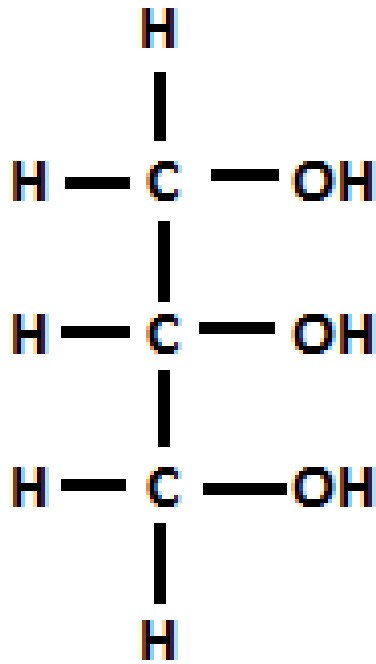
When cryoprotectant is added into the cell suspension, cytosolic water moves to the exterior milieu of the cell due to the water chemical potential difference between inside and outside of the cells. The penetrating cryoprotectant penetrates into cells because of the concentration difference. This process lasts until an equilibrium between intracellular and extracellular environments for both water and cryoprotectant is reached. The freezing point of the intracellular medium is decreased, and the intracellular ice formation (IIF) can be eliminated or prevented. Penetrating cryoprotectants penetrate into the cells, form new hydrogen bonds with water molecules by breaking the hydrogen bonds between them, and thereby change the structure of water. In this way, the cryoprotective function exhibits by preventing the cells from reaching high concentration of ions and avoiding extreme dehydration due to water loss during freezing [47].

Penetrating cryoprotectants such as glycerol, dimethyl sulfoxide ( $\text{Me}_2\text{SO}$  or DMSO), ethylene glycol, formamide, 1,2-propanediol, 2,3-butanediol, and propylene glycol affect spermatozoa during cryopreservation by changing the physical properties of intracellular solution, decreasing the intracellular ice formation, increasing the resistance to cold shock, regulating the protein and lipid structure of the cell membrane, and increasing membrane fluidity [48]. In the following part, two most widely used penetrating cryoprotectants, glycerol and DMSO, will be discussed.

#### *5.1.1 Glycerol*

Many penetrating cryoprotectants have been tested, giving different results in cryopreservation of gamet cells of different species. However, the most commonly used penetrating cryoprotectant is still glycerol, which was discovered in 1949 by Polge et al. [3] as a result of sperm vitrification.

As shown in **Figure 10**, a glycerol molecule contains three hydroxyl groups. Each glycerol molecule is capable of binding to three water molecules. Because of the



**Figure 10.**  
*Diagram of a glycerol molecule.*

smaller molecular size, glycerol can easily pass through the membrane pores. With the decrease of temperature, the hydroxyl bonds formed between water molecules get hardened and solidified. For this reason, the frozen water expands and damages the cell. As a cryoprotectant, glycerol exerts its function by preventing water molecules from becoming large-volume ice crystals by binding to the hydrogen atom of the water molecules and interlocking during freezing.

In addition to the osmotic effect on cells, glycerol directly acts on the cell membranes. Amann and Picket [49] have shown that glycerol exerts its primary effect in the extracellular environment, but it also intracellularly affects the cell membranes and organelle membranes. It binds to phospholipid groups in the plasma membrane, reduces the membrane fluidity, [50] and also forms a particulate clump in the membrane by interacting with membrane proteins and glycoproteins [51, 52]. At the same time, it creates structures similar to gap junctions (small connection channels between cells) in the membrane, reduces the electrical capacitance of the membrane, and causes large-scale rearrangement of membrane structure [53]. Glycerol causes a decrease in the membrane fluidity by providing interactions between the inner and outer layers of the membrane through regulating the structure of fatty acid acyl chains. Glycerol also affects the polymerization (creating multiple monomers to form larger and differently shaped macromolecules, called polymers) and depolymerization (decomposition of large macromolecules into smaller monomers) of microtubules, which indirectly affect the plasma membrane. Changes in the microtubule structures in the tail of spermatozoon influence the interactions between microtubule-associated proteins [54].

While glycerol has many benefits as a cryoprotectant, its use in high dose has a detrimental effect on the cells. These harmful effects appear in at least seven cellular activities:

- It denatures proteins [46].
- It increases the viscosity of cytosol.



- It causes changes in the polymerization and depolymerization of  $\alpha$  and  $\beta$  tubulins, the basic proteins of the microtubules found in the spermatozoon tail.
- It causes structural changes in the microtubuli.
- It acts on the bioenergetic balances.
- It acts directly on the plasma membrane and glycocalyx (a meshwork cell coat that is formed mainly by external proteins, externally-located glycoproteins and glycolipids providing various chemical interactions between the cell and the external milieu) [55].
- It creates osmotic stress due to slow penetration through the cell membrane than other cryoprotectants [56].

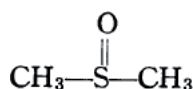
Si et al. measured the motility and integrity of both sperm and acrosomal membranes that were frozen with different concentrations of glycerol (2, 5, 10, and 15%) and dimethyl sulfoxide (2, 5, 10, and 15%) in their study on Rhesus monkeys. The highest motility was measured as 45.5% in the 5% glycerol group. In terms of membrane integrity, the control group had the highest score (77.9%), while the 5% glycerol group had lower value (61.6%). Values of acrosomal integrity were 91.2 and 82.4% for the control group and 5% glycerol group, respectively. When these two parameters taken into consideration, DMSO had lower augmenting effects on Rhesus monkey semen than glycerol [57].

Awad and colleagues compared glycerol, ethylene glycol, and methanol as cryoprotectants and measured the sperm motility post thawing. The best result was obtained with 3% glycerol (72.4% motility). Motilities of sperm cryopreserved with 3% ethylene glycol or 3% methanol were significantly lower (56.9 and 22.6%, respectively) [58].

### 5.1.2 Dimethyl sulfoxide (DMSO)

Dimethyl sulfoxide (DMSO) is a liquid at room temperature with color scale changing from colorless to yellow. It is soluble in water, ethanol, acetone, diethyl ether, benzene, chloroform, as well as in aromatic compounds. Apart from being a cryoprotectant for semen, DMSO also has anti-inflammatory properties, bacteriostatic and tranquilizing effects, diuretic and local analgesic activity. It is a penetrant and carrier, and it can strengthen the effect of insulin [59] (**Figure 11**).

When used in concentration of 5–10%, DMSO protects against damage on mouse T and B lymphocytes [60], human embryos [61], and many cellular systems during freezing and thawing. Sometimes, DMSO has even higher protective potential than that of glycerol in freezing sperm of some animal species, such as elephants [62, 63]. Despite that DMSO has the same mechanism of action with glycerol, DMSO has lower penetrability in human and porcine spermatozoons [64]. At the same time, DMSO has better protective capacity than glycerol and ethylene glycol in sperm freezing/thawing process and is more active in testicular tissues than glycerol and 1,2-propanediol [7].



**Figure 11.**  
Diagram of DMSO molecule.

Anchordoguy et al. used different cryoprotectants (DMSO, glycerol, proline, sucrose, and trehalose) for shrimp sperm and measured the viability. DMSO showed the highest viability (56.3%), followed by glycerol (29.3%). Proline and sucrose gave similar viability (24.5%), whereas trehalose gave relatively lower viability (16.2%). The group without cryoprotectant did not show any viability after thawing [65].

Two used different concentrations of DMSO and glycerol in this study of cryopreservation of semen of black grouper fish and graded the motility scores from 0 to 4. The level 0 means no motility, 1 means 0–25% motility, 2 means 25–50% motility, 3 means 50–75% motility, and 4 means 75–100% motility. Results of the study revealed that 10% DMSO resulted in level 3 of motility, 20% DMSO resulted in level 4, and 30% DMSO resulted in level 1. However, glycerol solutions with different concentrations showed level 0 motility [66].

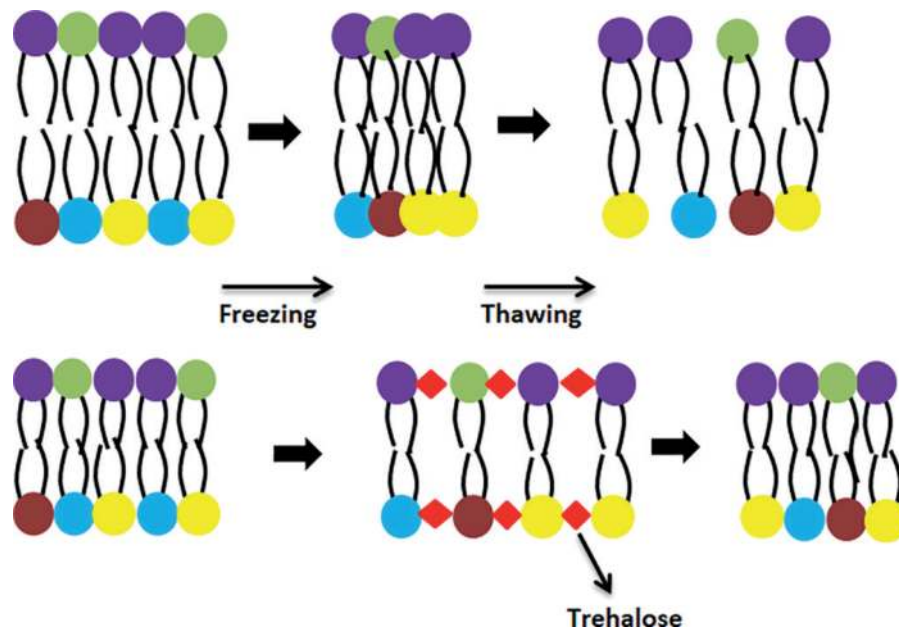
## 5.2 Non-penetrating cryoprotectants

Non-penetrating cryoprotectants cannot penetrate through the sperm membrane and only act in the extracellular environment. They also function by incorporating the membrane structure or reducing the freezing point of the medium [48]. They are generally divided into two groups: low molecular weight cryoprotectants and high molecular weight cryoprotectants [45]. Non-penetrating cryoprotectants with low molecular weight include three subgroups as monosaccharides (glucose and galactose), disaccharides (sucrose and trehalose), and trisaccharides (raffinose and melezitose). Cryoprotectants with high molecular weight [e.g., polyethylene glycol (PEG), ficoll 70, polyethylene oxide (PEO), polyvinyl alcohol (PVA), polyvinyl pyrrolidone (PVPP), etc.] exert their functions by reducing the ice crystals formed externally during the freezing/thawing process to decrease cellular damage. As a special and effective cryoprotectant, trehalose will be discussed as follows.

Sugars used during sperm cryopreservation serve as an energy source and an osmotic pressure regulator, cryoprotectant, and cellular ice formation reducer [67]. As a disaccharide formed by binding two D-glucose molecules, trehalose extends the distance between the membrane phospholipids by binding to the polar part of the phospholipids in the cell membrane. These cavities formed in the membrane prevent the formation of ice in the cell by helping the outflow of water from the cell during freezing, preventing harmful effect of cellular dehydration, and stabilizing the cell membrane.

Phospholipids accumulate due to van der Waals forces when energy is drawn from the environment by cooling sperm and transition occurs from liquid crystal phase to gel phase. During thawing, irregular voids occur in the cell membrane. This causes damage in the membrane structure, irregular ion and water leakage both into and out of the cell [68]. When trehalose is added into the medium, it forms gaps between phospholipids in the cell membrane and these gaps prevent the phospholipids from aggregation during freezing and protect the entity of membrane structure after thawing [69] (**Figure 12**).

In a study by Bucak et al. on freezing ram semen, two different doses of glutathione (5, 10 mM), taurine (50, 100 mM), and trehalose (50 and 100 mM) were used as cryoprotectants, and motility of the semen samples were measured at 0, 6, 24 and 30 h post thawing. The highest motility was obtained in samples containing 50 mM trehalose [67]. Hu et al. investigated cryopreservation capacity of trehalose on five different groups of bull sperm. Group 1 was the control group without trehalose, whereas groups 2–5 contained trehalose with concentrations of 25, 50, 100 mM trehalose, and 200 mM. The group with 100 mM trehalose had the highest semen motility, mitochondrial activity, acrosome integrity than those of the other



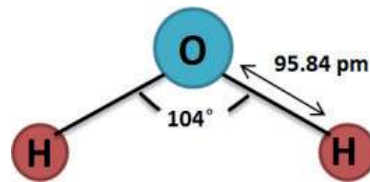
**Figure 12.**  
Schematic drawing of cryoprotective effect of trehalose on membrane phospholipids.

groups [70]. Öztürk et al. studied the effect of arginine and trehalose on bovine sperm samples in their study. Trehalose showed higher (50.5% subjective, 64.7% CASA) motility than arginine (29% subjective, 12.2% CASA) when compared to the control group [71]. Uysal and Bucak studied rapid (10°C/min from 5 to -25°C, 50°C/min from -25 to -130°C) and slow (0.5°C/min from 5 to -25°C, 50°C/min from -25 to -130°C) cooling rates with different doses of trehalose (0, 50, 100, 150 mM), and investigated sperm motility, survivability, membrane integrity, and morphologically abnormal sperm rates after thawing. Evaluations showed that the medium with 100 mM trehalose resulted in the best scores (sperm motility 72.0%, morphologic sperm abnormalities 25.5%, sperm viability 75.9%, and sperm membrane integrity 68.2%) [72]. Bucak and his colleagues also used trehalose (50, 100 mM), taurine (25, 50 mM), cysteamine (5, 10 mM), and hyaluronan (0.5, 1 mM) as antioxidants in their study of ram sperm cryopreservation. Motility, acrosomal damage, viability, and total abnormality parameters were examined. The group with 50 mM trehalose, 25 mM taurine, and 5 or 10 mM cysteamine provided the best results [73].

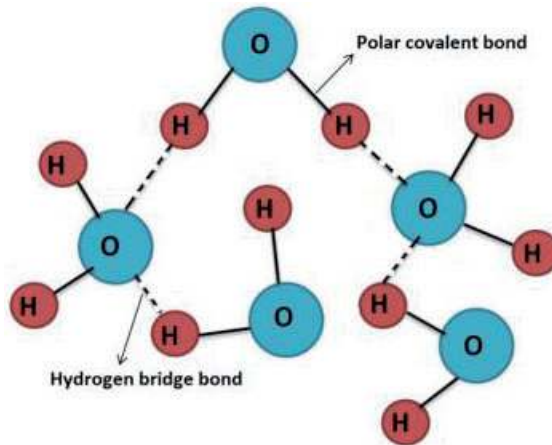
## 6. Molecular structure of water in liquid and solid phases

As the main source of life, water is different from most of the other molecules in the nature. Depending on the amount of energy in the environment, the water molecules undergo changes in their structure and phase transitions occurring between liquid, solid, and gas phases. Water molecules are in the liquid phase at the mammalian body temperature and perform very important tasks in almost every living cell.

The water molecule consists of two hydrogen atoms binding to a negatively charged oxygen atom at an angle of 104.52° with covalent bonds of 95.84 picometer in length [74] (**Figure 13**). Hydrogen bonds are formed between water molecules (**Figure 14**). The fluid structure of the water at room temperature is based on the fact that these bonds are constantly breaking and re-bonding [75].



**Figure 13.**  
*Schematic drawing of the hydrogen bridge bond.*



**Figure 14.**  
*Schematic drawing of water molecules.*

As mentioned earlier, water molecules are in liquid form in living organisms. However, during cooling, the covalent bonds between oxygen and hydrogen are shortened and the hydrogen bonds become hardened and extended. So, they tend to line up in a symmetrical manner and to expand. Important effects on water-based biological molecules should not be overlooked. The water itself is described as a biomolecule, even as the 21st amino acid [76]. In some cases, the ability of protein molecules to perform their normal functions depends on the presence of water molecules on their surface [77]. The bond between water and protein surface is formed by giving the proton in the hydrogen atom of water to the protein or by taking the proton in the hydrogen of the amine group and its derivatives (NH, NH<sub>2</sub>, NH<sub>3</sub>), which forms the backbone of proteins. Water molecules also build bridges ("water bridges") to provide interactions between the atoms of different protein molecules [78].

## 7. Cryobiological events during freezing and thawing

During cooling and thawing, spermatozoa undergo various changes in their chemical and physical status. The first one is the phase change of lipids in the sperm membrane, generally happening between 17 and 36°C. Different lipids have different phase transition temperatures. Proteins are normally found in asymmetric position between the membrane lipids in the liquid crystal structure. When the lipids transform to gel phase, membrane structures are disrupted and ion metabolism is regulated. When the membrane lipids are in liquid crystal or gel phases, the leakage of liquid electrolyte through the membrane is minimal. However, during phase changes of lipids, the membrane permeability is increased [79], which causes

solute leakage. Lipid phase changes occur not only during cooling but also during thawing. Fluorescent diacetate leaching was observed in the spermatozoa treated with fluorescent diacetate and re-dissolved by cooling to  $-5$ ,  $-10$  and  $-20^{\circ}\text{C}$  [19].

The second change that takes place is the transformation of the cytosolic water in the cell into ice. Spontaneous ice formation occurs between  $-5$  and  $-15^{\circ}\text{C}$ . Generally, above  $-5^{\circ}\text{C}$ , the internal and external milieu of the cell are supercooled, and no ice formation is observed. At the temperature between  $-5$  and  $-10^{\circ}\text{C}$ , ice formation starts in the extracellular environment, then cells are dehydrated and intracellular environment is supercooled. The fate of the cryopreserved cells, life or death, depends on the following cooling and thawing process [28].

### 7.1 Cryobiological damages during freezing

As mentioned in the two factor hypothesis proposed by Peter Mazur, damage arising from freezing occurs through two components. The first one can be defined as the direct damage caused by ice (ice injury), and the second one as the effect of the solution ion concentration on the cell (solution injury) [2].

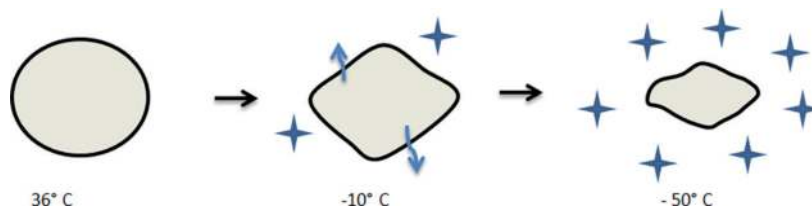
However, this situation appears in different manners in male and female gametes. While intracellular ice formation is observed in mammalian oocytes and embryos at different degrees of cooling [80], the case is not the same for spermatozoa [81]. The main factors include the pressure on spermatozoa caused by ice crystals formed in the external environment and the harmful effect of the high concentration of salt and mineral inside the cell.

### 7.2 Two-factor hypothesis of cryoinjury

The two-factor hypothesis suggested by Peter Mazur can be explained as follows:

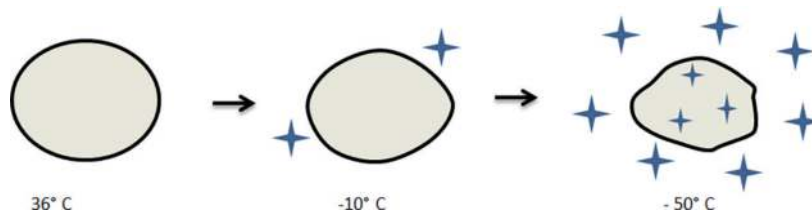
*Factor 1:* During cooling, extracellular ice formation happens first, which leads to the increase of solute concentration outside of cells. If the cooling rate is slow enough, the cells will have enough time to dehydrate and the cytosolic water will outflow from the cells until it is balanced with extracellular water. Dehydration of cells may include a few steps: separation of water molecules from the cytoplasmic liquid environment to the lipid part, diffusion in the lipid bilayer, and migration from lipid to external fluid, all of which are associated with activation energy (threshold energy value for a chemical reaction to takes place) (**Figure 15**). In this case, injury to the cells is majorly from the highly concentrated solutes in the cells [16]. Some biological constructs (e.g., eight-cell embryos) may be resistant to solution effects [82].

*Factor 2:* If the cooling rate is rather high, the cells will not have enough time to discharge cytosolic water into the extracellular environment, and water will freeze inside the cells [16] (**Figure 16**).



**Figure 15.** Schematic of factor 1 in “two-factor” hypothesis of cryoinjury. During slow cooling procedure, intracellular water has enough time to outflow from the cells.





**Figure 16.** Schematic of factor 2 in “two-factor” hypothesis of cryoinjury. If cells are cooled rapidly, water does not have time to outflow and freezes both inside and outside of the cells.

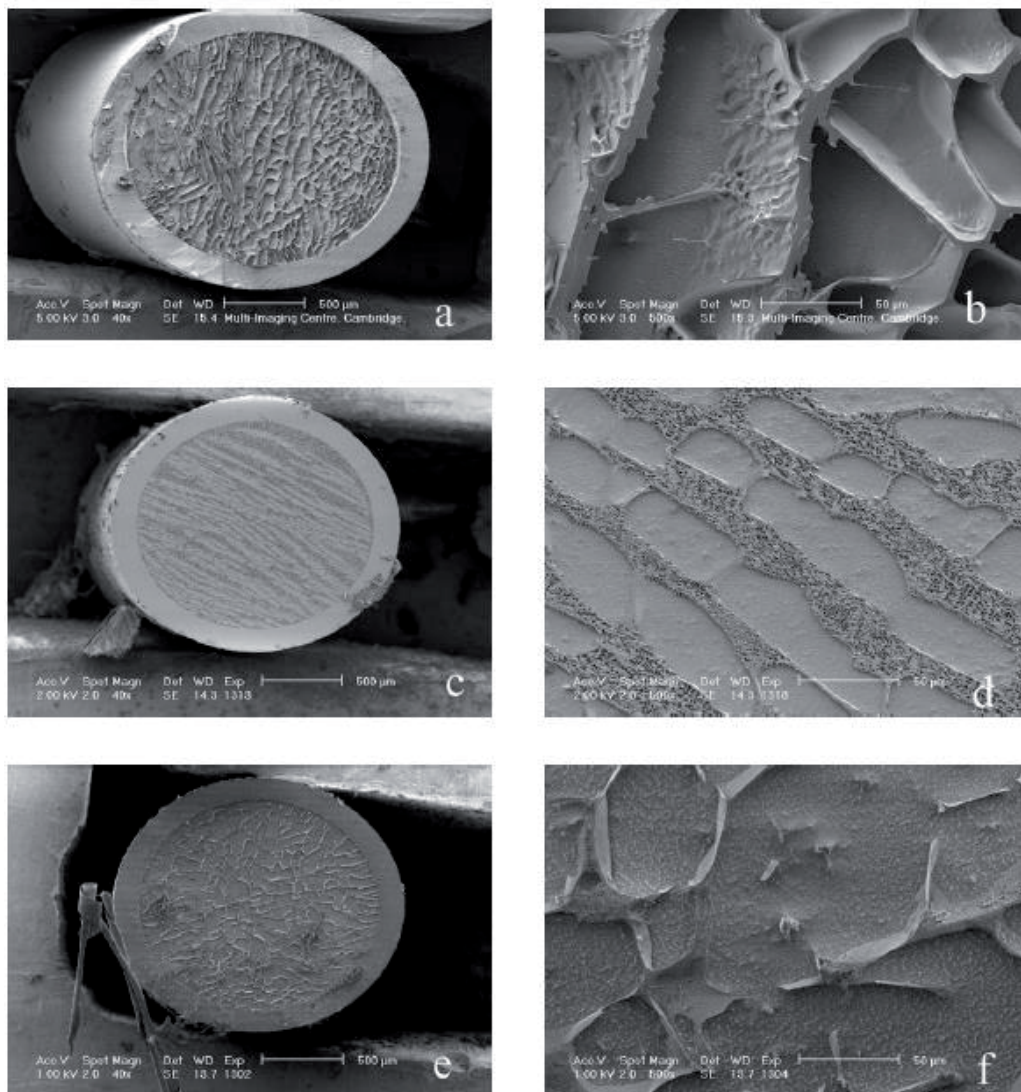
In more detail, when the cells are cooled slow enough, the cells dehydrate and an increase in the intracellular solute concentration is observed before reaching the freezing temperature. In long term, the cells are damaged due to severe dehydration and the increased intracellular ion concentration, which allows the exchange of some critical ions (e.g., potassium) via channels in the membranes [83]. The increase in the ion concentration causes the water-insoluble proteins in the cell to interfere with these ions and transit into a soluble form. The osmotic pressure remains unchanged as these ions bound to proteins causing an artificial decrease in intracellular ion concentration. Protein concealment of intracellular potassium and chloride ions allows the entry of sodium from exterior, and the cytosolic ion concentration increases again. During defrosting, the extracellular ice first melts, dilutes the outer environment, and water enters the cells. As the amount of cytosolic water increases, the potassium and chlorine-binding proteins liberate from the bonds and the hidden potassium and chloride reappear. As the amount of intracellular ions increases, the cells begin to rehydrate, during which process cracks in the cell membrane and cell lysis were observed [82].

On the other side, if the cells are cooled down too quickly, the intracellular water will not have enough time to balance with the extracellular environment, freeze inside the cells, and damage the intracellular structure and cell membrane [6]. The inhibition of intracellular ice formation by cryoprotectants is undoubtedly helpful on the survival of the cell [84]. However, the increase in the amount of intracellular solution leads to damages such as protein denaturation, cell lysis (cell membrane breakage), and mitochondrial and nucleus damage [85].

The morphological and physiological differences in the spermatozoa of different animal species must be taken into consideration. Thus, the sperm of different species will have different responses to cryopreservation; therefore, the optimal cryopreservation protocol would be different for them. For example, the optimal cooling rate was 100°C/min for the bull sperm, whereas 1–10°C/min for human [84], 30–50°C/min for pig [85], and 50–60°C/min for ram [45, 86].

Morris used different cryoprotecting agents (CPAs) in the sperm cryopreservation with both rapid and slow cooling procedures (**Figures 17 and 18**) [87]. Bucak et al. studied the protective effects of different antioxidants added to the diluent medium on cryopreserved spermatozoa (supported by the Scientific and Technological Research Council of Turkey, project No: 114O642). In this study, sperm cryodamages were ultrastructurally demonstrated. In the Scanning Electron Microscopy (SEM), vacuole-like structure and head, neck, tail deformations were visualized (**Figure 19**) [88]. In the Scanning Transmission Electron Microscopy (STEM), membrane deformations, head, axoneme, acrosome, mitochondrion damages, and double tail were observed (**Figure 20**) [88].

Ice crystals formed in the extracellular medium also act on the cytosol and may result in intracellular ice formation. When cells are in close proximity or in contact



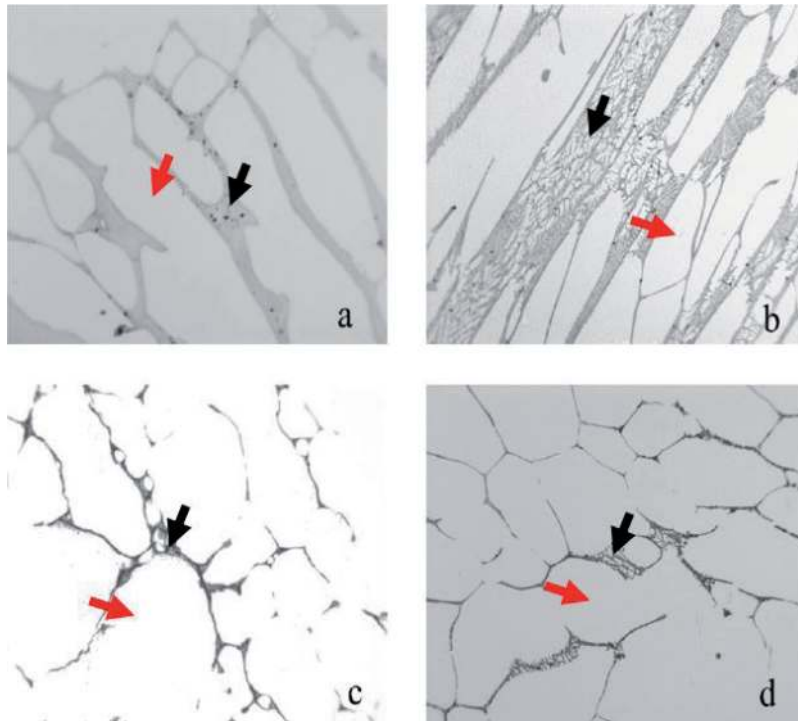
**Figure 17.**

*In (a) and (b), samples with added glycerol (3 volumes of 0.1 M sodium citrate to 1 volume of 0.33 M fructose and 1 volume of 0.33 M glucose + 4 ml of egg yolk +3 ml of glycerol) were frozen at 10°C/min visualized with a Cryo-scanning electron microscope. In (c) and (d): Glycerol added samples were frozen at 3000°C/min. In (e) and (f), sperm were frozen at 3000°C/min without glycerol. In (a), there are channels occurs (in which the spermatozoa can be protected) under the effect of glycerol, whereas (c) shows narrow channels as opposed to (a). In (e) no cryoprotectant substance is added and it is observed that the formed ice does not leave enough space for spermatozoa. This is illustrated in more detail in **Figure 18** [87].*

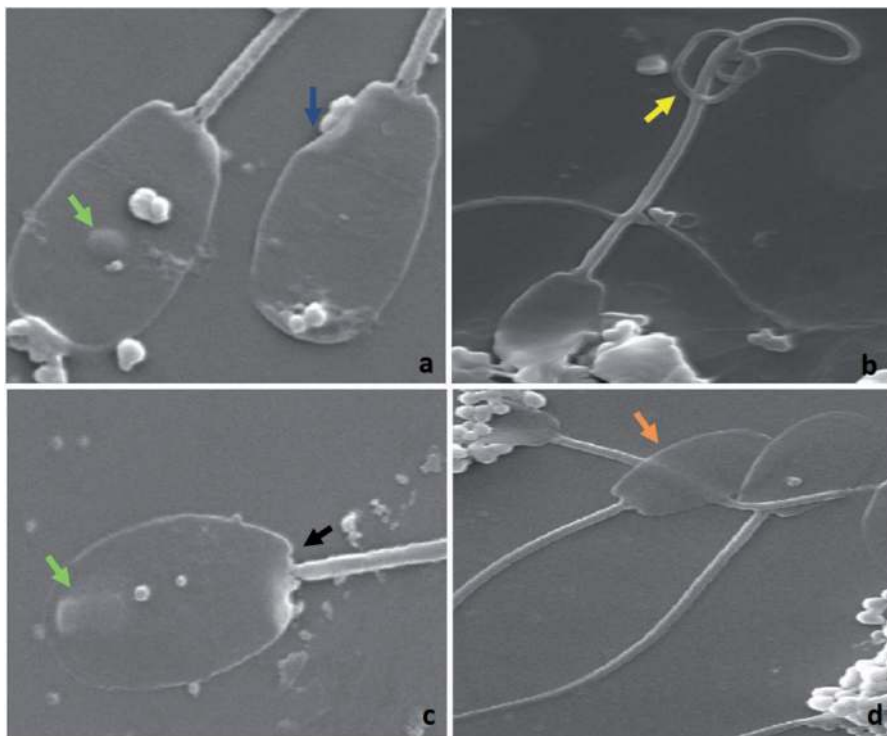
with any of extracellular ice crystals, the aquaporin channels in the cell membrane are also affected. Small ice crystals penetrate through the aquaporins into the cytosolic milieu and may trigger intracellular ice formation [34].

### 7.3 Damage during thawing

Rapid cooling causes the formation of small intracellular ice crystals. Such small ice crystals have higher energy than large ice crystals because of their small radius curves and they are thermodynamically more irregular. Due to this free energy difference, they show melting at lower temperatures than large ice crystals. Recrystallization is a phenomenon that small ice crystals combine together into larger ones, which cause defects such as various cuts and defects on organelles and membranes in the cell by physical pressure or crystals [87, 90]. Damage due to

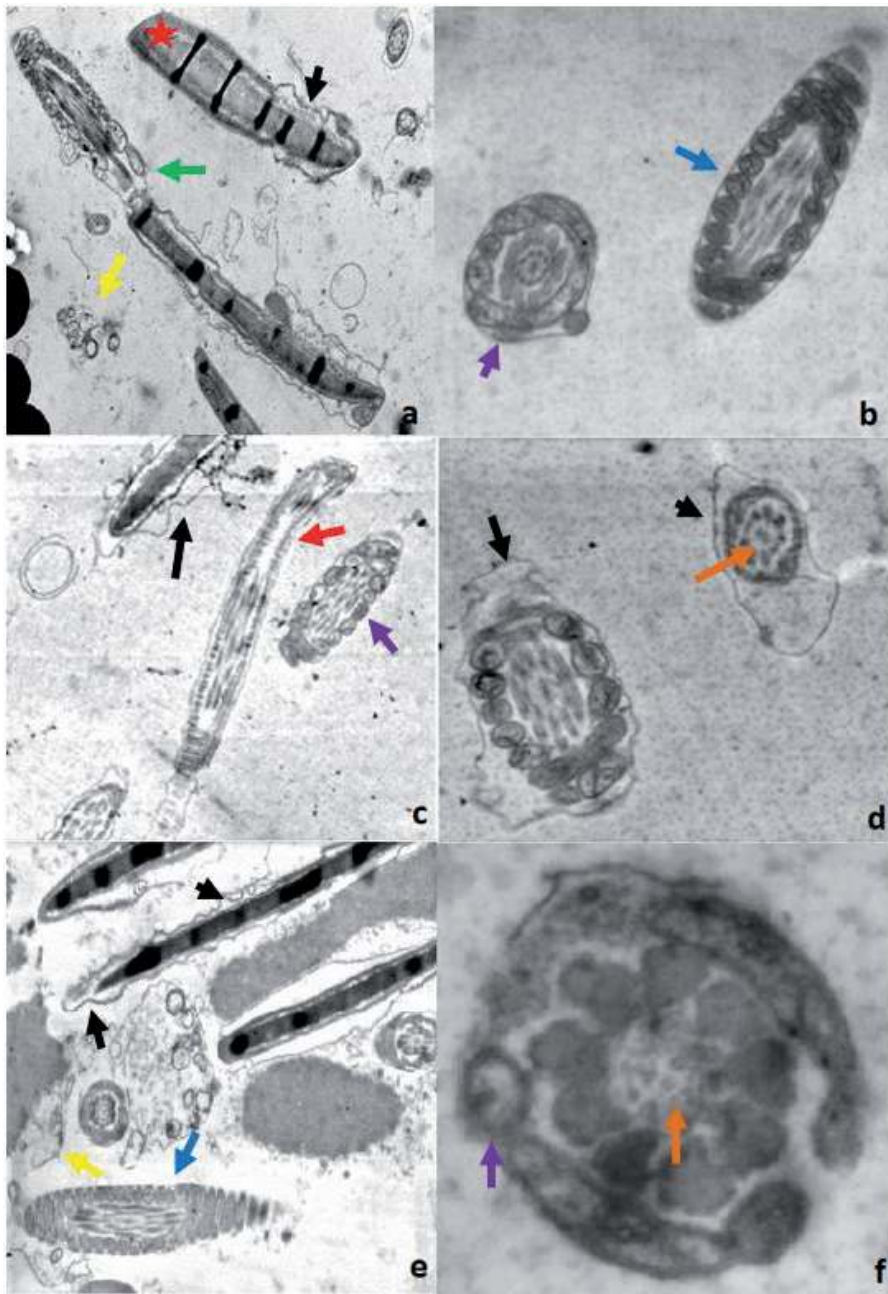


**Figure 18.**  
 In the above photographs, glycerol was added and frozen at a rate of  $10^{\circ}\text{C}/\text{min}$  (a), glycerol added and frozen at  $3000^{\circ}\text{C}/\text{min}$  (b), frozen at  $10^{\circ}\text{C}/\text{min}$  without glycerol (c), and frozen at  $3000^{\circ}\text{C}/\text{min}$  without glycerol (d) samples are illustrated. In the photo shown with the letter A, there is an unfrozen section between the ice masses (red arrow), where cells locate themselves, in the photograph b, the same frozen part is observed but in this part there are small pieces of ice in pieces and it poses a danger to the cells. While there are much smaller frozen canals on c photo, there is small ice crystals in the d picture, even in the unfrozen canals (black arrow) [87].



**Figure 19.**  
 SEM micrographs of frozen-thawed spermatozoa. (a) Vacuole-like structures (green arrow), head damage (blue arrow). (b) Tail damage (yellow arrow). (c) Vacuole-like structures (green arrow), neck damage (black arrow). (d) Normal sperm (orange arrow). a, c:  $10,000\times$ , b:  $5000\times$ , d:  $3000\times$  [88].





**Figure 20.** STEM micrographs of frozen-thawed spermatozoa, (a) nucleus (red star), membrane damages (black arrow), neck damage (green arrow), membrane fragments (yellow arrow). (b) Mitochondrial damage (purple arrow), undamaged middle region (blue arrow). (c) Membrane damages (black arrow), mitochondrial damage (purple arrow), damaged middle region (red arrow). (d) Membrane damages (black arrow), axoneme damage (orange arrow). (e) Membrane damages (black arrow), membrane fragments (yellow arrow), undamaged middle region (blue arrow). (f) Undamaged middle region (blue arrow), axoneme damage (orange arrow) [88, 89].

intracellular ice formation and recrystallization has been demonstrated in yeast, plant cells [91], hamster tissue culture cells [92], and turkey sperm [93]. During defrosting, recrystallization generally starts at  $-40^{\circ}\text{C}$ , and it becomes intense at the temperature range of  $-25$  to  $-20^{\circ}\text{C}$ .

The recrystallization mechanism consists of three types, isomass, active, and migratory.

1. *Isomass*: Isomass is a form of recrystallization that changes the shape of ice crystal. It can also be defined as the tendency of uneven rough surfaced or protruding ice particles combined to form larger particles having a more oval and smooth surface (**Figure 21**).



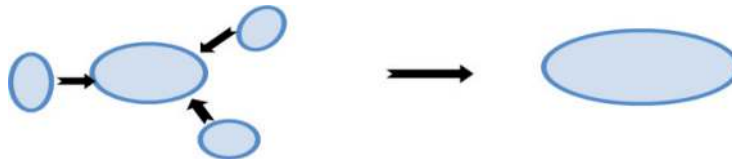
**Figure 21.**  
*Schematic drawing of isomass recrystallization.*

2. *Active*: In the active recrystallization model, two or more smaller ice crystals combine to form a larger ice crystal (**Figure 22**).



**Figure 22.**  
*Schematic drawing of active recrystallization.*

3. *Migratory*: In the migratory recrystallization model, small crystals around a large crystal melt into a large crystal structure (**Figure 23**).



**Figure 23.**  
*Schematic drawing of migratory recrystallization [91].*

Results of the previous studies revealed that the effect of ice formation or recrystallization depends on the crystal size [93] and on the total amount of ice in the cell [94]. In this context, rapid thawing protocol is more beneficial in terms of motility, viability, and membrane-organellar integrity, since small ice crystals do not have enough time to recrystallize when a fast warming protocol is applied. However, Mackenzie has shown that yeast cells cooled in optimal rate do not survive if they are quickly thawed, but sustain vitality when they are slowly thawed [92].

Another damage during thawing is due to the osmotic stress. This is especially true in frozen thawed rabbit [95], mouse [96], and bovine embryos and also freeze-thawed lymphocytes [97] and hematopoietic cells [16, 98]. In addition, remaining cryoprotective agents inside the cell are incorporated into the cytosolic water, lead to cell swollen, and cause various damage in the cell membrane, possibly cell lysis [99].

In the fertilization process, when the sperm reaches the fertilization zone, it enters between oviductal epithelial cells, infiltrates into the oocyte zona



pellucida, undergoes acrosome reaction, opens a pore in the zone pellucida, and finally reaches oolemma. Disturbances in sperm membrane function due to cryopreservation directly affect this entire fertilization mechanism. In this case, fertilization cannot occur under vivo conditions. A spermatozoon with poor motility will have difficulty reaching the fertilization zone, hence has a poor ability to fertilize ovum.

It has been found that after the freeze-thaw procedure, human and bull spermatozoa contain more calcium than unprocessed samples, due to impairment of the selective-membrane permeability of the spermatozoa. Also, the affected spermatozoa cannot exert normal capacitation and fertilization due to high calcium concentration of the cytosolic environment, which also leads to premature acrosomal defects and sperm hyperactivation, causes losses in both capacitation and acrosome reaction [100].

#### **7.4 The DNA damage**

Spermatozoa with DNA damage have relatively limited fertilization ability [101]. These cells have fertilization defects and potentially transfer abnormal genetic materials to the offsprings. These genetic disorders might result in abnormality in embryonic development and aneuploidies (a numerical chromosomal disorder in which the chromosome number differs from the normal, diploid (2n) [102]. Because the spermatozoa with serious genetic damage have low in-vivo and in-vitro fertilization scores, a limited number of embryo could be harvested and embryos will have many of the developmental problems. In the light of these findings, it was concluded that sperm chromatin/DNA integrity is an important prerequisite for healthy fertilization and embryonic development [103]. In addition to abnormal DNA/nuclear protein interactions arising from intracellular ice crystals [104], scientists attributed the DNA damage during freeze-thaw processes to two different mechanisms:

The first mechanism proposed by Zribi et al. [105] is due to DNA damage in cryopreservation, and is thought to be caused by the activation of caspases and apoptosis. According to this hypothesis, apoptotic body-like structures are formed in the sperm cells during the freezing process. Apoptotic changes show themselves as nuclear fragmentation, chromatin condensation, mitochondrial expansion, and unusual changes in the cell membrane [106]. These changes produce the enzymes from cysteine protease group, called caspases, which play an important role during apoptosis. These enzymes are found in the cytoplasm as pro-caspases in zymogen granules and their activation requires a two-step cleavage in the specific aspartic acid residues to form active holoenzymes [9]. The caspases activate sequentially (waterfall-like reaction sequence), leading to a proteolytic helmet. Initiator caspases transduce death signals initiated by apoptotic stimulation to effector caspases. The effector caspases are related proteins, for example, actin or fodrin from cytoskeletal proteins, lamin-A, the nuclear membrane protein, and poly (ADP-ribose) polymerase (PARP) involved in DNA repair break down apoptotic cell morphology [8]. DNA fragmentation is the latest sign of apoptosis, which occurs due to caspase-3 activation. The caspase-3 enzyme inhibits DNA repair by inactivating DNA repairing enzymes namely poly ADP-ribose polymerase (PARP) **Table 2**.

Current studies have shown that there is a positive correlation between the presence of PARP protein and sperm maturation. PARP homologs PARP-1 (75 kDa), PARP-9 (63 kDa), and PARP-2 (60 kDa) were found in injected sperm [107]. In another study [108], oxidative stress and PARP inhibition occurred in early

Subgroup	Function	Member
I	Activator (initiator caspases)	Caspase 2
		Caspase 8
		Caspase 9
		Caspase 10
II	Executioner (Effector caspases)	Caspase 3
		Caspase 6
		Caspase 7
III	Inflammatory mediators	Caspase 1
		Caspase 4
		Caspase 5
		Caspase 11
		Caspase 12
		Caspase 13
		Caspase 14

**Table 2.**  
*Caspase family subgroups and their members [8].*

apoptotic spermatozoa, with water leakage, cell shrinking, and picnosis (volume reduction of the cell nucleus and chromatin condensation). The apoptosis-inducing factor released by the mitochondria (flavin), an enzyme that contains adenine dinucleotide helps oxidization during oxidative phosphorylation, causes DNA fragmentation in flavoprotein [109, 110]. During freezing and thawing, an increase in apoptosis markers was observed. Changes in the apoptotic membrane permeability, membrane potential, caspase activation, and phosphatidylserine externalization due to cryopreservation are also observed [111].

The second mechanism proposed by Thomson et al. [112] is that DNA damage is caused by caspase activation and oxidative stresses in the apoptotic cells exposed to extreme hostility. It is highly possible that freeze-thaw process results in the formation of free oxygen radicals that damage the nuclear DNA [113, 114]. With the weakened DNA repair mechanism [115], the frozen-thawed sperms are vulnerable to oxidative attacks [116]. An increase in the mitochondrial membrane potential due to changes in its membrane fluidity during sperm cryopreservation was also observed, which leads to the formation of free oxygen radicals. Accordingly, DNA damage to the spermatozoon single and double strand breaks by the released free oxygen radicals are very common. The formation of free oxygen radicals reaches peak level in human sperm and seminal leukocytes at 4°C [117]. Frozen semen samples containing high percentage of sperm are more prone to DNA damage. Although the cryopreservation adversely affects antioxidant activity, interestingly, it makes spermatozoa less vulnerable to free oxygen radical damage [118].

The DNA damage in the cryopreserved spermatozoa mainly occurs at early stages during/after thawing. In a previous experiment [119], the highest DNA damage score was observed within the first 4 h after thawing. Therefore, freeze-thawed semen samples should be used immediately in the clinical settings [119]. However, Isachenko et al. [120] suggested that freezing or cryoprotectant did not make any difference in DNA integrity in their study **Table 3**.

References	Cryopreservation method	Results
Spano et al. [122], Donnelly et al. [123], Gandini et al. [124], Zribi et al. [105]	Equilibration at 37°C, freezing in liquid nitrogen at -80°C, storage in liquid nitrogen at -196°C	The freezing/thawing procedure causes DNA damage in the sperm.
De Paula et al. [125]	Freezing up to -20°C, freezing in liquid nitrogen, storage in liquid nitrogen at -196°C	
Petyim and Choavaratana [126]	Freezing with liquid nitrogen under computer control	
Ngamwuttiwong and Kunathikom [127]	Freezing in liquid nitrogen vapor	
Thomson et al. [112]	Programmable freezer	
Steele et al. [128]	Freezing in liquid nitrogen vapor	
Duru et al. [129]	Equilibration at 37°C, freezing in liquid nitrogen at -80°C, storage in liquid nitrogen at -196°C	
Isachenko et al. [130]	Programmable slow cooler + vitrification	
Paasch et al. [131]	Cooling to -20°C, freezing in liquid nitrogen at -100°C, storage in liquid nitrogen at -196°C	

**Table 3.**

*Different studies showing the effects of freezing/thawing protocols on DNA damage [121].*

## 7.5 The mitochondrial damage

Mitochondria and other membrane-bound organelles are found in the majority of eukaryotic cells and the mitochondria have a vital role in ATP synthesis in cells via oxidative phosphorylation [132]. Mitochondrion is found in nine fibrous columns located in the body of the spermatozoon and serves as an energizing engine for the semen [133]. Plasma membranes and mitochondrial membranes show similar sensitivity to cryopreservation. High levels of cholesterol and polyunsaturated fatty acids cause the membrane to become more fluidic under cold conditions.

Mitochondrion is unique double membrane-bound organelle in the cell. There is an intermembrane space between the inner and outer mitochondrial membranes. Matrix facing surface of the inner membrane have oxidative-phosphorylation enzyme system and the cytoplasmic part consisting of structural and functional subunits in which many enzymes are organized. These proteins are crucial for the metabolic processes required by the cell and for the maintenance of the cellular structure. Morphologically, the mitochondria show different characteristics in the sperm of different animal species. While in humans, rhesus monkey, dogs and other mammals, the mitochondria are in oval form, whereas they are cylindrical in fish [134]. The size and number of mitochondria in a given cell may vary according to the bioenergetic needs of species. Mitochondrion has its own DNA (mtDNA) involved in the synthesis of messenger RNA, ribosomal RNA, and transfer RNA, which are highly needed for the internal metabolism of the cell [135]. In the mammalian spermatozoa, mitochondria are located at the middle part of the cell and will form multiple disulfide bonds to form the mitochondrial capsule [136, 137].

Sperm mitochondria, unlike those of the somatic cells, include cytochrome c, cytochrome c oxidase subunits, protein isoforms, and isoenzymes. Mitochondria play a very fundamental role in ATP production by oxidative phosphorylation. In the production of mitochondrial ATP, glycolysis uses carbon fuels such as pyruvate, glutamine, and amino acids [135]. At the same time, mitochondria are involved in other processes such as production of free radicals and apoptosis. The release of free oxygen radicals such as superoxide anion, hydrogen peroxide, and nitric oxide is important. If the free oxygen radical release exceeds the capacity of the antioxidant defense system of a cell, peroxidation of the biological membranes, especially sperm plasma membrane and undesirable conditions can induce oxidative stress, DNA-related aging, and apoptosis [138]. Most importantly, the mitochondria create the activation energy required for the movement of the sperm [139].

ATP formed by oxidative phosphorylation in mitochondria allows motility through microtubules. For this reason, any disorder in the mitochondrion metabolism leads to decreased motility. Oxidative phosphorylation in the mitochondrion requires two basic components in the inner membrane of the mitochondrion, the ATP synthase, and the respiratory chain [140].

During cryopreservation, two types of damage occur in mitochondria. The first is the direct damage in the mitochondrial DNA, deteriorations in the inner and outer membranes of the mitochondrion. The second is the indirect damage caused by losing ability to carry out genetic coding for mitochondrial activity [141]. According to Irvine et al. [142], motility and velocity decrease in sperm with high DNA damage. The nuclear DNA segments damaged during freeze-thawing process may be responsible for the loss of mitochondrial functions.

A change in the mitochondrial membrane fluidity also causes changes in the membrane potential and in exchange and release of free oxygen radicals through the mitochondrial membrane [107]. Peroxidative damage caused by an increase in the concentration of free oxygen radicals is associated with sperm plasma membrane damage and disruption of the aczonemal structure [143].

## **7.6 Free oxygen radicals and lipid peroxidation damage**

Cryobiological events that occur during freezing not only cause physical damage but also disrupt the chemical structures. The cooling of the cell results in the production of free radicals, and it also suppresses the natural defensive mechanism that the cell develops against the formation of free radicals.

Depending on their low activation energy, the free oxygen radicals are more difficult to be removed at low temperatures than the normal enzymatic cleansing. Increasing amounts of free oxygen radicals affect various biomolecules including membrane lipids, proteins, and nucleic acids through nonenzymatic pathways and cause the formation of new free oxygen radicals in the environment. Transition metals such as copper and iron, which are highly effective in intracellular metabolism, such as the cytochromes of the mitochondrial electron transport chain, are important catalysts for the radical chain reactions. In particular, when catalysts are present in the species capable of redox cycling, they exchange electrons mutually between the oxidation sites.

The disruption of the homeostatic balance of the metal inlet and outlet of the cell during cooling leads to the formation of free oxygen radicals, damages the cell wall by thickening. Under normal conditions, while the formation and decomposition of free oxygen radicals are in equilibrium, the disruption of this equilibrium causes continuous formation and association of free oxygen radicals. Restricted free oxygen radicals cause damage to the cellular membrane by impairing lipid

peroxidation. Under normal conditions, the cells have ways to repair such damage, but irreversible damage during storage and thawing can lead to cell death.

During irreversible cell damage or cell death, calcium is an important agent in the cell necrosis. Due to the cold shock, unbalanced free radical formation causes an increase in intracellular calcium. All of these events have increased the importance of antioxidants and calcium channel blockers (calcium enters and exits through the calcium channels in the membrane from the extracellular medium, and this entry-exit mechanism is controlled by the so-called calcium channel blockers) during freezing and thawing. These blockers consist of three prototype agents, diltiazem, verapamil, and nifedipine, and many sub-agents such as amlodipine, benidipine, cilnidipine, felodipine, isradipine, nilvadipine, etc.

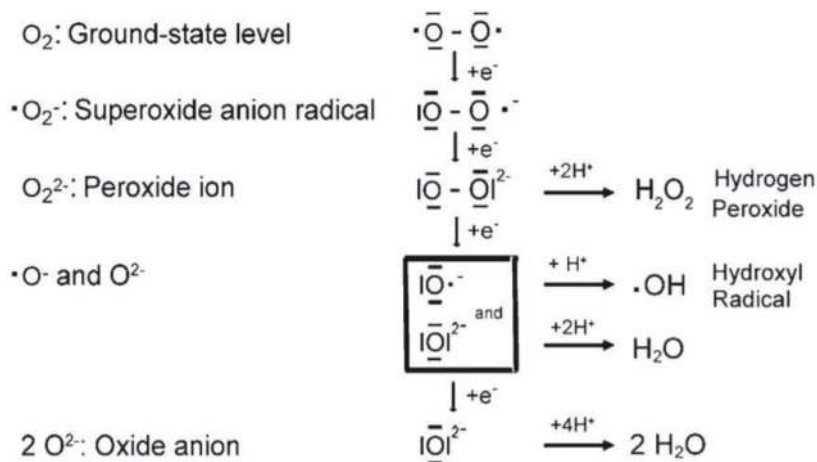
Free oxygen radicals are separated into three groups;

1. *Oxygen free radicals*: superoxide anions ( $O_2^-$ ), hydroxyl radical (OH), and hydroperoxyl radical (HOO).
2. *Non-radical species*: hypochloric acid (HOCl) and hydrogen peroxide ( $H_2O_2$ ).
3. *Reactive nitrogen species and free nitrogen radicals*: nitroxyl, nitrogen oxide, peroxyxynitrite, etc. [144].

Chemically, radicals are molecules having one or more unpaired electrons. This chemical state causes an excessive amount of reactivity with an electrically irregular structure in the predominant molecules. As in the other cells, energy is also produced aerobically in the spermatozoa. Energy is produced by oxidative phosphorylation in mitochondria and by oxidation of nicotinamide adenine dinucleotide (NADH) and is stored in the form of adenosine triphosphate (ATP). In this whole electron transfer chain, oxygen is reduced to free radicals in high electroactivity by taking four electrons. As a result of this reduction reaction, water becomes clear (**Figure 24**).

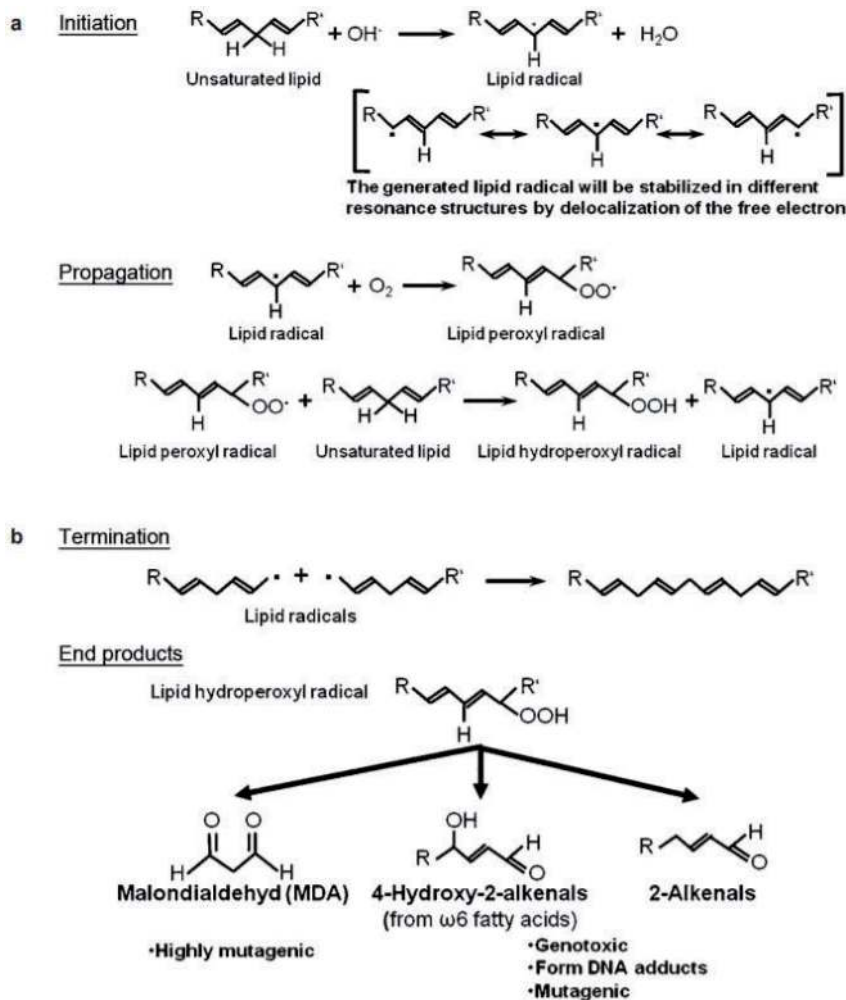
### 7.6.1 Lipid peroxidation

Reactive oxygen groups, which occur during the electron transport chain in the mitochondria, act on membrane lipids, rich in unsaturated fatty acids, causing deterioration of their structure. This is called lipid peroxidation.



**Figure 24.** Formation of reactive oxygen species [145].





**Figure 25.** Formation stages, propagation, and end products of lipid peroxidation [145].

Lipid peroxidation is exerted in three phases, initiation, propagation, and termination:

*Initiation phase:* In the initial phase, the highly reactive OH<sup>-</sup> or hydroxyperoxyl radical (-HO<sub>2</sub>) removes a proton (H<sup>+</sup>) from the medium by affecting the polyunsaturated fatty acids in the lipid layer and converts their existing structure into a lipid radical and releases water. Low reactivity oxygen groups such as H<sub>2</sub>O<sub>2</sub> cannot initiate this reaction [146]. In the present case, lipid radicals can be in various forms with electrons in delocalized state. At this stage, lipid radicals can react with molecular oxygen and are converted to lipid peroxides.

*Propagation phase:* During the propagation phase, the lipid radical formed in the previous phase merges with the oxygen in the molecular state and forms the lipid peroxide radical. The lipid peroxide radical reacts with a neighboring fatty acid to form a new lipid peroxidase and becomes itself a lipid hydroperoxyl. The ongoing reactions in this way are also referred to as the “radical chain reaction.” The lipid peroxidation event affects 60% of the membrane lipids [147].

*Termination phase:* In the last phase, two or more lipid radicals bind to each other to form hydroperoxyl radicals such as malandialdehyde (MDA), 4-hydroxy-2-alkene, and 2-alkenal, which have dangerous properties in the last stage (Figure 25).

## 8. Antioxidants as cellular defense mechanism

In the previous sections, we mentioned about the free oxygen radicals formed in the cell and the antioxidants those produced by the cells to protect themselves from diverse effects of free radicals.

Antioxidants exert their effects by:

- Preventing free oxygen radicals from starting chain reactions,
- Stopping chain reactions that have begun,
- Preventing the formation of free oxygen radicals, and
- Performing peroxides by breaking down and reducing local oxygen concentration [148].

Under normal conditions, spermatozoa reduce antioxidants to counteract with free oxygen radicals that are produced metabolically. These molecules are mainly enzymes. The most known antioxidant enzymes are superoxide dismutase (converts the superoxide anion to  $H_2O_2$ ), glutathione peroxidase (detoxifies the organic peroxides), and catalase (converts  $H_2O_2$  to water) [149, 150]. However, an abnormally high amount of free oxygen radicals released by the freeze-thaw procedure, damage the cell by overcoming its antioxidant defense capacity. In such cases, different antioxidants are supplied into the diluent solutions [151].

Antioxidants are divided into primary and secondary antioxidants.

*Primary antioxidants:* The antioxidants which blocks the chain reaction by cutting in the half enter this group. Antioxidants of this group are mainly: tocopherols (vitamin E), butyl-hydroxyl-anisole (BHA), butyl-hydroxy-toluene (BHT), and ethoxiquine.

*Secondary antioxidants:* These kinds of *antioxidants* prevent oxidation of lipids by delaying their oxidation. They act by binding to metal ions, which catalyze the oxidation of lipids, by binding oxygen itself, and by absorbing UV rays. Some antioxidants such as citric acid, amino acids, ethylene diamine tetra acetic acid (EDTA) and certain phosphoric acid derivatives, ascorbic acid (Vitamin C), ascorbyl palmitate, sulfites, erythorbic acid and sodium erythorbate, and glucose oxidase are examples of secondary antioxidants [152]. Bucak et al. obtained better spermatozoological parameters in the Ankara goat [153–155] and bull [156] spermatozoa frozen in the antioxidants added to the dilution solutions after thawing.

## 9. Discussion

The membrane structure in the semen cells is complex. Several types of phospholipids and proteins, cholesterol and oligosaccharides are involved in cell membrane structure in a manner appropriate for the cell structure and are effective in providing intracellular and extracellular balance.

The osmotic balance between the intracellular and extracellular environment, DNA integrity, the mitochondrial energy system, and many other systematic ovum fertilization by spermatozoa and the transfer of genetic material are all due to the complete and orderly functioning of this biological system as a whole. Although freezing and storing the semen samples at  $-196^\circ\text{C}$  has been a groundbreak in artificial insemination, despite all the precautions taken, a slight decrease in the motility and vitality caused by cold shock occurred during freezing procedure.

Rapid cooling of the cells disrupts the membrane structure, and cells are subjected to physical pressure from both inside and outside due to the formation of intracellular and extracellular ice. Although the slow cooling of the environment removes the physical impression of the ice, the cells are trapped in the solutes with a high ion concentration due to excessive water loss. For this reason, they are exposed to chemical deterioration.

To avoid these two situations, scientists have made efforts to determine the optimum cooling rate, and finally, optimal cooling rates have been determined for the semen of different mammalian species. In addition, various cryoprotectants have been used to prevent ice formation and deterioration of membrane integrity, but these substances with various side effects have also damaged the cells when supplemented.

DNA, which has a highly complex structure, is damaged even when the cooling rate and cryoprotectant are applied at optimal levels. The free oxygen radicals, which are formed as a result of slow metabolism, terrorize the cellular milieu, deteriorate the metabolism, and disrupt almost all functions of the cell. Against these toxic agents, cells produce protective mechanisms called antioxidants, but they are ineffective against high concentrations of free radicals, which are formed excessively in the cold environment. Artificial antioxidants added into the solutions do not provide the desired success so far. Sperms can also be damaged due to recrystallization during thawing.

## **10. Conclusion**

In this chapter, we provide detailed information about cryobiology and cryopreservation of sperm. Necrosis and apoptosis of the cell during freezing are described. The structure of the biological membranes is detailed, the damages of the membranes during the cryopreservation process are mentioned and some cryoprotectants used against membrane damages are given. The structure of water, the mechanism of freezing and ice formation, and the effect of intracellular/extracellular water presence on cryopreservation were explained. These data were enriched with electron microscope images. Apart from physical damage, DNA damage, mitochondrial damage, ROS formation, lipid peroxidation damage, and antioxidative defense mechanism are mentioned. A comprehensive section on cryobiology and freezing of spermatozoa has been tried to be prepared, and it is aimed to give detailed information about cryopreservation.

## **Author details**

Ali Erdem Öztürk<sup>1</sup>, Mustafa Numan Bucak<sup>1</sup>, Mustafa Bodu<sup>1</sup>, Nuri Başpınar<sup>2</sup>, İlhami Çelik<sup>3</sup>, Zhiquan Shu<sup>4,5</sup>, Nazan Keskin<sup>6</sup> and Dayong Gao<sup>4\*</sup>

1 Department of Reproduction and Artificial Insemination, Selcuk University, Konya, Turkey

2 Department of Biochemistry, Selcuk University, Konya, Turkey

3 Department of Histology and Embryology, Selcuk University, Konya, Turkey

4 Department of Mechanical Engineering, University of Washington, Seattle, WA, USA


5 School of Mechanical and Materials Engineering, Washington State University, Everett, WA, USA

6 Department of Histology and Embryology, Pamukkale University, Denizli, Turkey

\*Address all correspondence to: [dayong@uw.edu](mailto:dayong@uw.edu)

## **IntechOpen**

---

© 2019 The Author(s). Licensee IntechOpen. This chapter is distributed under the terms of the Creative Commons Attribution License (<http://creativecommons.org/licenses/by/3.0>), which permits unrestricted use, distribution, and reproduction in any medium, provided the original work is properly cited. 

## References

- [1] Spallanzani L, Di Pietro P. Edizione nazionale delle opere di Lazzaro Spallanzani: Charles Bonnet. Mucchi; 1776
- [2] Pesch S, Bergmann M. Structure of mammalian spermatozoa in respect to viability, fertility and cryopreservation. *Micron*. 2006;**37**:597-612
- [3] Polge C, Smith AU, Parkes A. Revival of spermatozoa after vitrification and dehydration at low temperatures. *Nature*. 1949;**164**:666
- [4] Bucak MN, Tekin N. Kryopro-tektañlar ve gamet hücrelerinin dondurulmasında kryoprotektif etki. *Ankara Üniversitesi Veteriner Fakültesi Dergisi*. 2007;**54**:67-72
- [5] Whittingham D, Leibo S, Mazur P. Survival of mouse embryos frozen to  $-196$  and  $-269^{\circ}\text{C}$ . *Science*. 1972;**178**:411-414
- [6] Gao D, Critser J. Mechanisms of cryoinjury in living cells. *ILAR Journal*. 2000;**41**:187-196
- [7] Benson JD, Woods EJ, Walters EM, Critser JK. The cryobiology of spermatozoa. *Theriogenology*. 2012;**78**:1682-1699
- [8] Ozaydin T, Celik I. Histological, histochemical and immuno-histochemical investigations on the developing small intestines of broilers embryos. *Journal of Animal and Veterinary Advances*. 2012;**11**:2936-2944
- [9] Samali A, Orrenius S. Heat shock proteins: Regulators of stress response and apoptosis. *Cell Stress and Chaperones*. 1998;**3**:228
- [10] Wyllie A, Duvall E. Cell injury and death. In: McGee JO'D, Isaacson PG, Nicholas A, Heather WM, Mary DPE, editors. *Oxford Textbook of Pathology. Principles of Pathology*. Vol. 1. Oxford, UK: Oxford University Press; Slack. 1992. pp. 141-193
- [11] Tinaztepe K, Ozen S, Güçer S, Ozdamar S. Apoptosis in renal disease: A brief review of the literature and report of preliminary findings in childhood lupus nephritis. *The Turkish Journal of Pediatrics*. 2001;**43**:133-138
- [12] Abastado J-P. Apoptosis: Function and regulation of cell death. *Research in Immunology*. 1996;**147**:443-456
- [13] Gabai VL, Meriin AB, Mosser DD, Caron A, Rits S, Shifrin VI, et al. Hsp70 prevents activation of stress kinases a novel pathway of cellular thermotolerance. *Journal of Biological Chemistry*. 1997;**272**:18033-18037
- [14] Nagle WA, Soloff BL, Moss A, Henle KJ. Cultured Chinese hamster cells undergo apoptosis after exposure to cold but nonfreezing temperatures. *Cryobiology*. 1990;**27**:439-451
- [15] Elkind MM, Whitmore GF. *Radiobiology of Cultured Mammalian Cells*. New York, London: Gordon and Breach; 1967
- [16] Mazur P. Freezing of living cells: Mechanisms and implications. *American Journal of Physiology-Cell Physiology*. 1984;**247**:C125-C142
- [17] Singer S, Nicolson GL. The fluid mosaic model of the structure of cell membranes. *Science*. 1972;**175**:720-735
- [18] Parks JE, Graham JK. Effects of cryopreservation procedures on sperm membranes. *Theriogenology*. 1992;**38**:209-222
- [19] Holt W. Basic aspects of frozen storage of semen. *Animal Reproduction Science*. 2000;**62**:3-22



- [20] Cabrita E, Sarasquete C, Martínez-Páramo S, Robles V, Beirão J, Pérez-Cerezales S, et al. Cryopreservation of fish sperm: Applications and perspectives. *Journal of Applied Ichthyology*. 2010;**26**:623-635
- [21] Simpson A, Swan M, White I. Susceptibility of epididymal boar sperm to cold shock and protective action of phosphatidylcholine. *Molecular Reproduction and Development*. 1987;**17**:355-373
- [22] Sariozkan S, Tuncer P, Bucak M, Buyukleblebici S, Kinet H, Bilgen A. The effects of different egg yolk concentrations used with soy bean lecithin-based extender on semen quality to freeze bull semen. *Eurasian Journal of Veterinary Sciences*. 2010;**26**:45-49
- [23] Brill JA, Yildirim S, Fabian L. Phosphoinositide signaling in sperm development. *Seminars in Cell and Developmental Biology*. 2016;**59**:2-9
- [24] Luconi M, Marra F, Gandini L, Filimberti E, Lenzi A, Forti G, et al. Phosphatidylinositol 3-kinase inhibition enhances human sperm motility. *Human Reproduction*. 2001;**16**:1931-1937
- [25] de Vantéry Arrighi C, Lucas H, Chardonnes D, De Agostini A. Removal of spermatozoa with externalized phosphatidylserine from sperm preparation in human assisted medical procreation: Effects on viability, motility and mitochondrial membrane potential. *Reproductive Biology and Endocrinology*. 2009;**7**:1
- [26] Wilhelm K, Graham J, Squires E. Effects of phosphatidylserine and cholesterol liposomes on the viability, motility, and acrosomal integrity of stallion spermatozoa prior to and after cryopreservation. *Cryobiology*. 1996;**33**:320-329
- [27] Yeagle PL. *The Membranes of Cells*. London: Academic Press; 2016
- [28] Medeiros CMO, Forell F, Oliveira ATD, Rodrigues JL. Current status of sperm cryopreservation: Why isn't it better? *Theriogenology*. 2002;**57**:327-344
- [29] Van Dijck P, De Kruijff B, Van Deenen L, De Gier J, Demel R. The preference of cholesterol for phosphatidylcholine in mixed phosphatidylcholine-phosphatidylethanolamine bilayers. *Biochimica et Biophysica Acta (BBA)—Biomembranes*. 1976;**455**:576-587
- [30] Yeagle PL. Cholesterol and the cell membrane. *Biochimica et Biophysica Acta (BBA)—Reviews on Biomembranes*. 1985;**822**:267-287
- [31] Flesch FM, Brouwers JF, Nievelstein PF, Verkleij AJ, van Golde LM, Colenbrander B, et al. Bicarbonate stimulated phospholipid scrambling induces cholesterol redistribution and enables cholesterol depletion in the sperm plasma membrane. *Journal of Cell Science*. 2001;**114**:3543-3555
- [32] Visconti PE, Ning X, Fornés MW, Alvarez JG, Stein P, Connors SA, et al. Cholesterol efflux-mediated signal transduction in mammalian sperm: Cholesterol release signals an increase in protein tyrosine phosphorylation during mouse sperm capacitation. *Developmental Biology*. 1999;**214**:429-443
- [33] Chapman D. Phase transitions and fluidity characteristics of lipids and cell membranes. *Quarterly Reviews of Biophysics*. 1975;**8**:185-235
- [34] Zhmakin AI. *Fundamentals of Cryobiology: Physical Phenomena and Mathematical Models*. Berlin: Springer; 2008

- [35] Yeung C-H. Aquaporins in spermatozoa and testicular germ cells: Identification and potential role. *Asian Journal of Andrology*. 2010;**12**:490-499
- [36] Seddon J, Templer R. Polymorphism of lipid-water systems. In: *Handbook of Biological Physics*. North Holland; Vol. 1. 1995. pp. 97-160
- [37] Killian JA, de Kruijff B. Nonbilayer lipids affect peripheral and integral membrane proteins via changes in the lateral pressure profile. *Biochimica et Biophysica Acta (BBA)—Biomembranes*. 2004;**1666**:275-288
- [38] Cullis PR, De Kruijff B. Lipid polymorphism and the functional roles of lipids in biological membranes. *Biochimica et Biophysica Acta (BBA)—Reviews on Biomembranes*. 1979;**559**:399-420
- [39] Quinn P. A lipid-phase separation model of low-temperature damage to biological membranes. *Cryobiology*. 1985;**22**:128-146
- [40] Hammerstedt R, Graham JK, Nolan JP. Cryopreservation of mammalian sperm: What we ask them to survive. *Journal of Andrology*. 1990;**11**:73-88
- [41] Caldarelli G, De Los Rios P. Cold and warm denaturation of proteins. *Journal of Biological Physics*. 2001;**27**:229-241
- [42] Farrant J, Molyneux P, Hasted J, Meares P, Echlin P. Water transport and cell survival in cryobiological procedures [and discussion]. *Philosophical Transactions of the Royal Society of London B: Biological Sciences*. 1977;**278**:191-205
- [43] Royere D, Barthelemy C, Hamamah S, Lansac J. Cryopreservation of spermatozoa: A 1996 review. *Human Reproduction Update*. 1996;**2**:553-559
- [44] Crowe J, Crowe L. Effects of dehydration on membranes and membrane stabilization at low water activities. *Biological Membranes*. 1984;**5**:57-103
- [45] Woelders H. Fundamentals and recent development in cryopreservation of bull and boar semen. *Veterinary Quarterly*. 1997;**19**:135-138
- [46] Alvarenga MA, Papa FO, Landim-Alvarenga F, Medeiros A. Amides as cryoprotectants for freezing stallion semen: A review. *Animal Reproduction Science*. 2005;**89**:105-113
- [47] Sağırkaya H, Bağış H. Memeli embriyolarının kriyoprezervasyonu. *Uludag University Journal of the Faculty of Veterinary Medicine*. 2003;**22**: 127-135
- [48] Purdy PH. A review on goat sperm cryopreservation. *Small Ruminant Research*. 2006;**63**:215-225
- [49] Amann R, Pickett B. Principles of cryopreservation and a review of cryopreservation of stallion spermatozoa. *Journal of Equine Veterinary Science*. 1987;**7**:145-173
- [50] Anchooguy TJ, Rudolph AS, Carpenter JF, Crowe JH. Modes of interaction of cryoprotectants with membrane phospholipids during freezing. *Cryobiology*. 1987;**24**:324-331
- [51] Armitage W. Osmotic stress as a factor in the detrimental effect of glycerol on human platelets. *Cryobiology*. 1986;**23**:116-125
- [52] Niedermeyer W, Parish G, Moor H. Reactions of yeast cells to glycerol treatment alterations to membrane structure and glycerol uptake. *Protoplasma*. 1977;**92**:177-193
- [53] Kachar B, Reese TS. Rapid formation of gap-junction-like structures induced by glycerol. *The Anatomical Record*. 1985;**213**:7-15

- [54] Keates RA. Effects of glycerol on microtubule polymerization kinetics. *Biochemical and Biophysical Research Communications*. 1980;**97**:1163-1169
- [55] Hammerstedt RH, Graham JK. Cryopreservation of poultry sperm: The enigma of glycerol. *Cryobiology*. 1992;**29**:26-38
- [56] Gilmore J, McGann L, Liu J, Gao D, Peter A, Kleinhans F, et al. Effect of cryoprotectant solutes on water permeability of human spermatozoa. *Biology of Reproduction*. 1995;**53**:985-995
- [57] Si W, Zheng P, Li Y, Dinnyes A, Ji W. Effect of glycerol and dimethyl sulfoxide on cryopreservation of rhesus monkey (*Macaca mulatta*) sperm. *American Journal of Primatology*. 2004;**62**:301-306
- [58] Awad M. Effect of some permeating cryoprotectants on CASA motility results in cryopreserved bull spermatozoa. *Animal Reproduction Science*. 2011;**123**:157-162
- [59] Pope D, Oliver W. Dimethyl sulfoxide (DMSO). *Canadian Journal of Comparative Medicine and Veterinary Science*. 1966;**30**:3
- [60] Strong DM, Ahmed AA, Sell KW, Greiff D. In vitro effects of cryoprotective agents on the response of murine T and B lymphoid subpopulations to mitogenic agents. *Cryobiology*. 1972;**9**:450-456
- [61] Trounson A, Mohr L. Human pregnancy following cryopreservation, thawing and transfer of an eight-cell embryo. *Nature*. 1983;**305**:707-709
- [62] Ashwood-Smith M. Current concepts concerning radioprotective and cryoprotective properties of dimethyl sulfoxide in cellular systems. *Annals of the New York Academy of Sciences*. 1975;**243**:246-256
- [63] Jones R. Collection, motility and storage of spermatozoa from the African elephant *Loxodonta africana*. *Nature*. 1973;**243**:38-39
- [64] Rota A, Milani C, Cabianna G, Martini M. Comparison between glycerol and ethylene glycol for dog semen cryopreservation. *Theriogenology*. 2006;**65**:1848-1858
- [65] Anchordoguy T, Crowe JH, Griffin FJ, Clark WH. Cryopreservation of sperm from the marine shrimp *Sicyonia ingentis*. *Cryobiology*. 1988;**25**:238-243
- [66] Gwo J-C. Cryopreservation of black grouper (*Epinephelus malabaricus*) spermatozoa. *Theriogenology*. 1993;**39**:1331-1342
- [67] Bucak MN, Tekin N. Protective effect of taurine, glutathione and trehalose on the liquid storage of ram semen. *Small Ruminant Research*. 2007;**73**:103-108
- [68] Patist A, Zoerb H. Preservation mechanisms of trehalose in food and biosystems. *Colloids and Surfaces B: Biointerfaces*. 2005;**40**:107-113
- [69] Ahmad E, Aksoy M. Trehalose as a cryoprotective agent for the sperm cells: A mini review. *Animal Health, Production and Hygiene*. 2012;**1**:123-129
- [70] Hu JH, Li QW, Jiang ZL, Yang H, Zhang SS, Zhao HW. The cryoprotective effect of trehalose supplementation on boar spermatozoa quality. *Reproduction in Domestic Animals*. 2009;**44**:571-575
- [71] Öztürk C, Güngör Ş, Ataman MB, Bucak MN, Başpınar N, İli P, et al. Effects of arginine and trehalose on post-thawed bovine sperm quality. *Acta Veterinaria Hungarica*. 2017;**65**:429-439
- [72] Uysal O, Bucak MN. The role of different trehalose concentrations and cooling rates in freezing of ram semen.

Ankara Universitesi Veteriner Fakultesi Dergisi. 2009;**56**:99-103

[73] Bucak MN, Ateşşahin A, Varışlı Ö, Yüce A, Tekin N, Akçay A. The influence of trehalose, taurine, cysteamine and hyaluronan on ram semen: Microscopic and oxidative stress parameters after freeze–thawing process. *Theriogenology*. 2007;**67**:1060-1067

[74] Benedict W, Gailar N, Plyler EK. Rotation-vibration spectra of deuterated water vapor. *The Journal of Chemical Physics*. 1956;**24**:1139-1165

[75] Finney JL. Water? What's so special about it? *Philosophical Transactions of the Royal Society of London B: Biological Sciences*. 2004;**359**:1145-1165

[76] Levy Y, Onuchic JN. Water mediation in protein folding and molecular recognition. *Annual Review of Biophysics and Biomolecular Structure*. 2006;**35**:389-415

[77] Oleinikova A, Brovchenko I, Smolin N, Krukau A, Geiger A, Winter R. Percolation transition of hydration water: From planar hydrophilic surfaces to proteins. *Physical Review Letters*. 2005;**95**: 247802

[78] Petukhov M, Rychkov G, Firsov L, Serrano L. H-bonding in protein hydration revisited. *Protein Science*. 2004;**13**:2120-2129

[79] Drobnis EZ, Crowe LM, Berger T, Anchordoguy TJ, Overstreet JW, Crowe JH. Cold shock damage is due to lipid phase transitions in cell membranes: A demonstration using sperm as a model. *Journal of Experimental Zoology*. 1993;**265**:432-437

[80] Mazur P. Principles of cryobiology. In: *Life in the Frozen State*. Boca Raton: CRC Press; 2004. pp. 3-65

[81] Mazur P, Koshimoto C. Is intracellular ice formation the cause of death of mouse sperm frozen at high cooling rates? 1. *Biology of Reproduction*. 2002;**66**:1485-1490

[82] Muldrew K. The salting-in hypothesis of post-hypertonic lysis. *Cryobiology*. 2008;**57**:251-256

[83] Lovelock J. The haemolysis of human red blood-cells by freezing and thawing. *Biochimica et Biophysica Acta*. 1953;**10**:414-426

[84] Henry MA, Noiles EE, Gao D, Mazur P, Critser JK. Cryopreservation of human spermatozoa. IV. The effects of cooling rate and warming rate on the maintenance of motility, plasma membrane integrity, and mitochondrial function. *Fertility and Sterility*. 1993;**60**:911-918

[85] Fiser P, Fairfull R. Combined effect of glycerol concentration and cooling velocity on motility and acrosomal integrity of boar spermatozoa frozen in 0.5 ml straws. *Molecular Reproduction and Development*. 1990;**25**:123-129

[86] Duncan AE, Watson P. Predictive water loss curves for ram spermatozoa during cryopreservation: Comparison with experimental observations. *Cryobiology*. 1992;**29**:95-105

[87] Morris G. Rapidly cooled human sperm: No evidence of intracellular ice formation. *Human Reproduction*. 2006;**21**:2075-2083

[88] Bucak NKM, Erdoğan C, İli AP, Başpınar N, Dursun Ş, Güngör Ş, et al. Effects of cryoprotectants and trehalose on electron microscopic evaluation of cryopreserved semen. *Journal of Reproduction and Infertility*. 2017;**18**:25-26

[89] Altuntaş CE. Ultrastructural investigation of the cryoprotective



- effects of trehalose on frozen-thawed ram spermatozoa [Msc thesis]. Denizli, Turkey: Department of Histology and Embryology, Pamukkale University Graduate School of Health Sciences; 2018
- [90] Lovelock JE. The denaturation of lipid-protein complexes as a cause of damage by freezing. *Proceedings of the Royal Society of London, Series B: Biological Sciences.* 1957;**147**:427-433
- [91] Oude Vrielink AS, Aloï A, Olijve LL, Voets IK. Interaction of ice binding proteins with ice, water and ions. *Biointerphases.* 2016;**11**:018906
- [92] MacKenzie A. Death of frozen yeast in the course of slow warming. In: *Ciba Foundation Symposium-The Frozen Cell.* London: Wiley Online Library; 1970. pp. 89-96
- [93] Shimada K. Effects of cryoprotective additives on intracellular ice formation and survival in very rapidly cooled HeLa cells. *Contributions from the Institute of Low Temperature Science.* 1977;**19**:49-69
- [94] Farrant J, Walter C, Lee H, McGann L. Use of two-step cooling procedures to examine factors influencing cell survival following freezing and thawing. *Cryobiology.* 1977;**14**:273-286
- [95] Bank H, Maurer R. Survival of frozen rabbit embryos. *Experimental Cell Research.* 1974;**89**:188-196
- [96] Whittingham D. The viability of frozen-thawed mouse blastocysts. *Journal of Reproduction and Fertility.* 1974;**37**:159-162
- [97] Thorpe P, Knight SC, Farrant J. Optimal conditions for the preservation of mouse lymph node cells in liquid nitrogen using cooling rate techniques. *Cryobiology.* 1976;**13**:126-133
- [98] Crowder J, Dunn C, Jones J. Cryopreservation of erythropoietin-responsive cells in murine hematopoietic tissue. *Cryobiology.* 1980;**17**:18-24
- [99] Gage AA, Baust J. Mechanisms of tissue injury in cryosurgery. *Cryobiology.* 1998;**37**:171-186
- [100] Bailey JL, Bilodeau J, Cormier N. Semen cryopreservation in domestic animals: A damaging and capacitating phenomenon. *Journal of Andrology.* 2000;**21**:1-7
- [101] Ardon F, Helms D, Sahin E, Bollwein H, Töpfer-Petersen E, Waberski D. Chromatin-unstable boar spermatozoa have little chance of reaching oocytes in vivo. *Reproduction.* 2008;**135**:461-470
- [102] Evenson D. Loss of livestock breeding efficiency due to uncompensable sperm nuclear defects. *Reproduction, Fertility and Development.* 1999;**11**(1):16
- [103] Fraser L, Strzeżek J, Kordan W. Effect of freezing on sperm nuclear DNA. *Reproduction in Domestic Animals.* 2011;**46**:14-17
- [104] Royere D, Hamamah S, Nicolle J, Lansac J. Chromatin alterations induced by freeze-thawing influence the fertilizing ability of human sperm. *International Journal of Andrology.* 1991;**14**:328-332
- [105] Zribi N, Chakroun NF, ElEuch H, Gargouri J, Bahloul A, Keskes LA. Effects of cryopreservation on human sperm deoxyribonucleic acid integrity. *Fertility and Sterility.* 2010;**93**:159-166
- [106] Kerr JF, Wyllie AH, Currie AR. Apoptosis: A basic biological phenomenon with wide-ranging implications in tissue kinetics. *British Journal of Cancer.* 1972;**26**:239



- [107] Said TM, Gaglani A, Agarwal A. Implication of apoptosis in sperm cryoinjury. *Reproductive Biomedicine Online*. 2010;**21**:456-462
- [108] Mahfouz RZ, Sharma RK, Poenicke K, Jha R, Paasch U, Grunewald S, et al. Evaluation of poly (ADP-ribose) polymerase cleavage (cPARP) in ejaculated human sperm fractions after induction of apoptosis. *Fertility and Sterility*. 2009;**91**:2210-2220
- [109] Candé C, Cohen I, Daugas E, Ravagnan L, Larochette N, Zamzami N, et al. Apoptosis-inducing factor (AIF): A novel caspase-independent death effector released from mitochondria. *Biochimie*. 2002;**84**:215-222
- [110] Martin G, Cagnon N, Sabido O, Sion B, Grizard G, Durand P, et al. Kinetics of occurrence of some features of apoptosis during the cryopreservation process of bovine spermatozoa. *Human Reproduction*. 2007;**22**:380-388
- [111] Martin G, Sabido O, Durand P, Levy R. Cryopreservation induces an apoptosis-like mechanism in bull sperm. *Biology of Reproduction*. 2004;**71**:28-37
- [112] Thomson LK, Fleming SD, Aitken RJ, DeIuliis GN, Zieschang J-A, Clark AM. Cryopreservation-induced human sperm DNA damage is predominantly mediated by oxidative stress rather than apoptosis. *Human Reproduction*. 2009;**24**:2061-2070
- [113] Baumber J, Ball BA, Linfor JJ, Meyers SA. Reactive oxygen species and cryopreservation promote DNA fragmentation in equine spermatozoa. *Journal of Andrology*. 2003;**24**:621-628
- [114] Lewis S, Aitken R. DNA damage to spermatozoa has impacts on fertilization and pregnancy. *Cell and Tissue Research*. 2005;**322**:33-41
- [115] Ahmadi A, Ng SC. Fertilizing ability of DNA-damaged spermatozoa. *Journal of Experimental Zoology*. 1999;**284**:696-704
- [116] Rath D, Bathgate R, Rodriguez-Martinez H, Roca J, Strzezek J, Waberski D. Recent advances in boar semen cryopreservation. In: *Control of Pig Reproduction VIII*. Nottingham University Press, Nottingham; 2009. pp. 51-66
- [117] Wang AW, Zhang H, Ikemoto I, Anderson DJ, Loughlin KR. Reactive oxygen species generation by seminal cells during cryopreservation. *Urology*. 1997;**49**:921-925
- [118] Lasso JL, Noiles EE, Alvarez JG, Storey BT. Mechanism of superoxide dismutase loss from human sperm cells during cryopreservation. *Journal of Andrology*. 1994;**15**:255-255
- [119] Gosálvez J, Cortés-Gutiérrez E, López-Fernández C, Fernández JL, Caballero P, Nuñez R. Sperm deoxyribonucleic acid fragmentation dynamics in fertile donors. *Fertility and Sterility*. 2009;**92**:170-173
- [120] Isachenko V, Isachenko E, Katkov II, Montag M, Dessole S, Nawroth F, et al. Cryoprotectant-free cryopreservation of human spermatozoa by vitrification and freezing in vapor: Effect on motility, DNA integrity, and fertilization ability. *Biology of Reproduction*. 2004;**71**:1167-1173
- [121] Di Santo M, Tarozzi N, Nadalini M, Borini A. Human sperm cryopreservation: Update on techniques, effect on DNA integrity, and implications for ART. *Advances in Urology*. 2012;**2012**:854837
- [122] Spano M, Cordelli E, Leter G, Lombardo F, Lenzi A, Gandini L. Nuclear chromatin variations in human spermatozoa undergoing swim-up and cryopreservation evaluated by the flow

cytometric sperm chromatin structure assay. *Molecular Human Reproduction*. 1999;5:29-37

[123] Donnelly ET, McClure N, Lewis SE. Cryopreservation of human semen and prepared sperm: Effects on motility parameters and DNA integrity. *Fertility and Sterility*. 2001;76:892-900

[124] Gandini L, Lombardo F, Lenzi A, Spano M, Dondero F. Cryopreservation and sperm DNA integrity. *Cell and Tissue Banking*. 2006;7:91-98

[125] de Paula TS, Bertolla RP, Spaine DM, Cunha MA, Schor N, Cedenho AP. Effect of cryopreservation on sperm apoptotic deoxyribonucleic acid fragmentation in patients with oligozoospermia. *Fertility and Sterility*. 2006;86:597-600

[126] Petyim S, Choavaratana R. Cryodamage on sperm chromatin according to different freezing methods, assessed by AO test. *Journal of The Medical Association of Thailand*. 2006;89:306-313

[127] Ngamwuttiwong T, Kunathikom S. Evaluation of cryoinjury of sperm chromatin according to liquid nitrogen vapour method (I). *Journal of the Medical Association of Thailand*. 2007;90:224

[128] Steele EK, McClure N, Lewis SE. Comparison of the effects of two methods of cryopreservation on testicular sperm DNA. *Fertility and Sterility*. 2000;74:450-453

[129] Duru NK, Morshedi MS, Schuffner A, Oehninger S. Cryopreservation-thawing of fractionated human spermatozoa is associated with membrane phosphatidylserine externalization and not DNA fragmentation. *Journal of Andrology*. 2001;22:646-651

[130] Isachenko E, Isachenko V, Katkov II, Rahimi G, Schondorf T,

Mallmann P, et al. DNA integrity and motility of human spermatozoa after standard slow freezing versus cryoprotectant-free vitrification. *Human Reproduction*. 2004;19:932-939

[131] Paasch U, Sharma RK, Gupta AK, Grunewald S, Mascha EJ, Thomas AJ Jr, et al. Cryopreservation and thawing is associated with varying extent of activation of apoptotic machinery in subsets of ejaculated human spermatozoa 1. *Biology of Reproduction*. 2004;71:1828-1837

[132] Devenish RJ, Prescott M, Rodgers AJ. The structure and function of mitochondrial F<sub>1</sub>F<sub>0</sub>-ATP synthases. *International Review of Cell and Molecular Biology*. 2008;267:1-58

[133] O'connell M, McClure N, Lewis S. The effects of cryopreservation on sperm morphology, motility and mitochondrial function. *Human Reproduction*. 2002;17:704-709

[134] Lahnsteiner F, Patzner RA. Sperm morphology and ultrastructure in fish. In: *Fish Spermatology*. Oxford, UK: Alpha Science International Ltd; 2008. pp. 1-61

[135] Piomboni P, Focarelli R, Stendardi A, Ferramosca A, Zara V. The role of mitochondria in energy production for human sperm motility. *International Journal of Andrology*. 2012;35:109-124

[136] Calvin HI, Cooper GW, Wallace E. Evidence that selenium in rat sperm is associated with a cysteine-rich structural protein of the mitochondrial capsules. *Gamete Research*. 1981;4:139-149

[137] Ursini F, Heim S, Kiess M, Maiorino M, Roveri A, Wissing J, et al. Dual function of the selenoprotein PHGPx during sperm maturation. *Science*. 1999;285:1393-1396

- [138] Figueroa E, Valdebenito I, Zepeda AB, Figueroa CA, Dumorné K, Castillo RL, et al. Effects of cryopreservation on mitochondria of fish spermatozoa. *Reviews in Aquaculture*. 2017;**9**:76-87
- [139] Guthrie H, Welch G. Effects of reactive oxygen species on sperm function. *Theriogenology*. 2012;**78**:1700-1708
- [140] Brown K. Fish mitochondrial genomics: Sequence, inheritance and functional variation. *Journal of Fish Biology*. 2008;**72**:355-374
- [141] Kurland C, Andersson S. Origin and evolution of the mitochondrial proteome. *Microbiology and Molecular Biology Reviews*. 2000;**64**:786-820
- [142] Irvine DS, Twigg JP, Gordon EL, Fulton N, Milne PA, Aitken R. DNA integrity in human spermatozoa: Relationships with semen quality. *Journal of Andrology*. 2000;**21**:33-44
- [143] Saleh R, Agarwal A. Oxidative stress and male infertility: From research bench to clinical practice. *Journal of Andrology*. 2002;**23**:737
- [144] Sabeti P, Pourmasumi S, Rahiminia T, Akyash F, Talebi AR. Etiologies of sperm oxidative stress. *International Journal of Reproductive BioMedicine*. 2016;**14**:231
- [145] Henkel RR. Leukocytes and oxidative stress: Dilemma for sperm function and male fertility. *Asian Journal of Andrology*. 2011;**13**:43
- [146] Blake D, Allen R, Lunec J. Free radicals in biological systems—A review orientated to inflammatory processes. *British Medical Bulletin*. 1987;**43**:371-385
- [147] Kothari S, Thompson A, Agarwal A, du Plessis SS. Free radicals: Their beneficial and detrimental effects on sperm function. *Indian Journal of Experimental Biology*. 2010;**48**:425-435
- [148] Cheeseman K, Slater T. An introduction to free radical biochemistry. *British Medical Bulletin*. 1993;**49**:481-493
- [149] Guemouri L, Artur Y, Herbeth B, Jeandel C, Cuny G, Siest G. Biological variability of superoxide dismutase, glutathione peroxidase, and catalase in blood. *Clinical Chemistry*. 1991;**37**:1932-1937
- [150] Marti E, Marti J, Muiño-Blanco T, Cebrián-Pérez J. Effect of the cryopreservation process on the activity and immunolocalization of antioxidant enzymes in ram spermatozoa. *Journal of Andrology*. 2008;**29**:459-467
- [151] Bucak MN, Tuncer PB, Sarıözkan S, Başpınar N, Taşpınar M, Çoyan K, et al. Effects of antioxidants on post-thawed bovine sperm and oxidative stress parameters: Antioxidants protect DNA integrity against cryodamage. *Cryobiology*. 2010;**61**:248-253
- [152] Ömür AD. Koç Spermasının Dondurulmasında Antioksidanların Etkisi. *Atatürk Üniversitesi Veteriner Bilimleri Dergisi*. 2015;**10**:61-69
- [153] Bucak MN, Sarıözkan S, Tuncer PB, Ulutaş PA, Akçadağ Hİ. Effect of antioxidants on microscopic semen parameters, lipid peroxidation and antioxidant activities in angora goat semen following cryopreservation. *Small Ruminant Research*. 2009;**81**:90-95
- [154] Bucak MN, Tuncer PB, Sarıözkan S, Ulutaş PA, Çoyan K, Başpınar N, et al. Effects of hypotaurine, cysteamine and aminoacids solution on post-thaw microscopic and oxidative stress parameters of angora goat

semen. *Research in Veterinary Science*.  
2009;**87**:468-472

[155] Bucak MN, Sariözkan S, Tuncer PB, Sakin F, Ateşşahin A, Kulaksız R, et al. The effect of antioxidants on post-thawed angora goat (*Capra hircus ancryrensis*) sperm parameters, lipid peroxidation and antioxidant activities. *Small Ruminant Research*. 2010;**89**:24-30

[156] Bucak M, Ataman M, Başpınar N, Uysal O, Taşpınar M, Bilgili A, et al. Lycopene and resveratrol improve post-thaw bull sperm parameters: Sperm motility, mitochondrial activity and DNA integrity. *Andrologia*. 2015;**47**:545-552