A Wearable Heating System with a Controllable e-Textile-Based Thermal Panel

Senem Kurşun Bahadır and Umut Kivanc Sahin

Additional information is available at the end of the chapter

<http://dx.doi.org/10.5772/intechopen.76192>

Abstract

Flexible textile heating systems present great advantage due to their ability to bend and hence could ensure uniform heating for irregular geometries. In cooler outer environment, the user requires his/her body to be kept warm for monitoring vital body functions within realistic thermal body balance constraints. In this chapter, heated vest with controllable e-textile-based thermal panel has been studied. Several e-textile-based thermal panels with different conductive yarns were produced using hot air welding technology under different manufacturing parameters. E-textile-based thermal panels were tested for their heating behaviors at varying direct current (DC) power levels. Based on the experimental results, the optimum e-textile-based thermal panel design was chosen considering its flexibility and uniform heating behavior. Moreover, a control algorithm with electrical circuit and electrical connection network was designed and assembled in an electronic control module. Finally, the electronic module consisting of power control and management system was integrated to attachable e-textile-based thermal panel in order to form a wearable heating vest.

Keywords: heating textiles, e-textiles, thermal panel, temperature control, welding, wearable electronics

1. Introduction

The rapid interest on Internet of Things (IoT) technologies together with electronics has brought up new, interesting and challenging fields of crossover electronics researches to our work, homes and daily life with an abundance of new viewpoints.

Wearable electronics, newly growing area in the global market, are being fundamentally designed to be worn to function, which makes them different from mobile devices. In the mid-1990s, mobile phones and internet technologies penetrated into human life with a dramatic increase and the mobile devices became smaller, more portable and affordable. In all over the world, most people particularly aged 15–35 know how to operate computers and mobile phones and they are becoming the focus of attention of IT industry incredibly. Thus, the body-worn computing devices are believed to be a hit in the global market within a decade [1].

The integration of wearable technology is expected to set and enhance the design concept of apparel sector in the near future; however, the functioning alone is not enough in the global market to sell a kind of “wearable electronic” product. Without compromising any traditional characteristics such as wearability and washability, the product will be meaningless to be purchased by the consumers in the market. Besides, some wearable electronics require the user interface to be present and available all the time which makes them very obtrusive compared to other wearable devices such as wrist belt for healthcare. In addition, the appearance of clothes, their color, shape, style, etc. are very important to enhance the desirability of the product from the viewpoint of marketing strategies.

Ideally, an intelligent garment presents functioning unlike traditional garment, such as health monitoring, detection of fall, identification of emergency, etc. It collects the data and transmits the data either wirelessly or wired solutions to an external computing unit, where the data is processed and interpreted; thus results in a response or feedback to a wearer/external center.

In this chapter, a design of an intelligent garment with a controllable e-textile (electronic textile)-based thermal panel for heating purpose is presented. Firstly, textile-based heating approaches will be described. Then, the design of a wearable heating system will be given in detail. Design of e-textile-based thermal panels with their production process will be issued. The electrical connection network of the heating jacket with thermal panels and an electronic control module consisting of power control and management system will be addressed. The chapter goes on the integration of electronic control module to textile structure and describes the development of a whole wearable heating vest system. The chapter then addresses the real-time monitoring of the heating vest performance. Throughout this chapter, the development stage of a kind of intelligent garment particularly; “wearable heating vest” from design concept to prototyping will be understood.

2. Textile-based heating approach

2.1. Principle of electrical resistance heating in textiles

An electric current passing through any conductive material will generate heat. In an electric resistance heating system, the electric current passing through the resistor generates an amount of heat depending on its level; however, the current flow is limited by the resistance and applied voltage in a circuit based on a basic principle of Ohm’s law (**Figure 1**) [2].

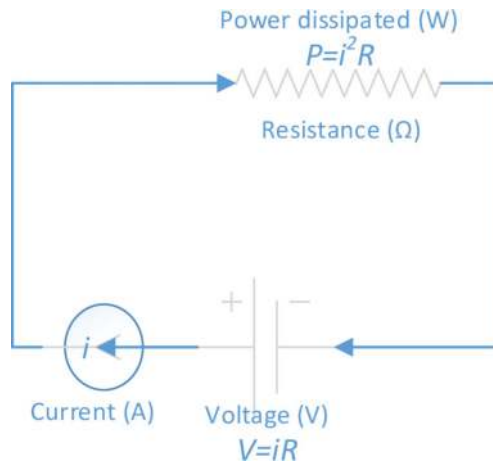

Figure 1. Ohm's law illustration.

Resistors with specific value can be manufactured in various shapes and sizes within a fabric. The area of the fabric in which the resistors are located has not any effect on the resistor's value. Independent from the area and the surface of the fabric, conductive elements can be placed in the form of parallel and series in order to form electrical networks inside/over the fabric structure. The resistance values can change depending on the conductive element type particularly from a few ohms to many kilo ohms. In fact, the linear resistance of conductive yarns/tracks defines the resistance values of electrical networks constructed in a fabric structure. The way of formation and insertion of conductive tracks are critical in a textile-based heating system since the manufacturing process can damage the conductive tracks hence may result in a decrease in conductivity level [3, 4]. Moreover, those conductive tracks used for wearable systems should be thin enough to be bend and to allow flexibility, and at the same time strong enough for not to be broken and provide an efficient heating [5].

Every square centimeter of fabric will dissipate heat in terms of several watts of power depending on the resistor conductivity level. In order to obtain higher power dissipation, the resistor can be scaled up in the fabric area, however in the case of high power dissipation, high level of power supply is mainly required.

For an efficient heat dissipation, to broaden the electrical network on a thin surface of the fabric is necessary. Indeed, the efficiency level at the dissipating heat due to the electrical network configuration on the fabric is one of the most important factors to have the efficient heating system [6]. For having flexible heating within a textile structure, the typical fabric constructions such as plain, twill weave patterns or single jersey, interlock etc. with typical fabric weight of 250 g/m^2 can be chosen. Composition of the fibers affects the washability and heating behavior of the system. For instance, the heating performance of wool fabric compared to cotton fabric is higher. For this reason, in a design of textile-based electrical heating system, if the cotton fabric is used as a base fabric for electrical network configuration then the system's

heating capacity apparently will be less compared to those from woolen fabrics. Therefore, to choose appropriate fiber composition plays an important role on the heating performance of the system.

In battery-powered portable applications, to specify the required wattage value rather than its rated voltage gives great flexibility to design heating system. Especially, to determine wattage value with a specified resistance value of the conductor will present great freedom for having e-textile-based thermal panels such that to calculate the required level of distance for insertion of conductive yarns/tracks and hence, the size of textile-based heating panels will become easy.

Overall, the area requiring heat should be wrapped with a flexible surface for having efficient heating performance due to heat delivery by conduction and convection mechanisms [7–9]. For this reason, textile-based electrical heating systems present great advantage for maintaining human body at vital required heat level by satisfying more contact with flexible architecture, thus little heat loss occurs. Moreover, the researches on textile-based electrical heating systems recently focused on the development of a product that can monitor and regulate human body temperature according to climate change particularly for outdoor activities like skiing, snowboarding. Although heated garments have an obvious appeal for outdoor activities, the limitations of battery technology restrict the scale of electrical heating in those applications.

2.2. Textile-based heating systems

Household textile objects, such as seating, carpets, bedding and towels can be heated based on e-textile design approach, without intrusive heater cables. In our urban living spaces, textile-based heating systems like heated curtains and carpets might eliminate the use of radiators and vents. Apart from household applications, outdoor apparel market is clearly very promising and affluent, i.e., jackets and gloves. However, the market is currently very small and has niche applications for heated wear from motorcyclists and scuba divers to cold water fish hunters, pylon riggers and cold-store workers.

The aim of the textile-based heating systems is to provide necessary warmth to the user/environment in a cooler environment. Warmth condition is necessary to keep the human body system to function [10]. The constant temperature of a human body for maintaining body functions is 37°C; anything below resulted by prolonged exposure to cold temperatures can cause hypothermia and can be fatal for the survival of human body [11–13]. Therefore, heating systems play a major role to keep human body maintained at vital required heat levels. The heat can be applied to different areas on the human body. However, the flexibility of the heating system is very important since the users'/system structures are mostly irregular shaped. Heating with non-flexible systems may cause great heat losses due to fewer contact. For this reason, textile-based heating systems are an added advantage because of efficient heat delivery mechanism by wrapping the structure due to its flexibility.

Textile-based heating systems can be grouped into two categories: polymer-based and metal-based textile heaters. Metal-based textile heaters include metals as heating elements while polymer-based textile heaters include polymer materials to generate heat [14].

As a metal-based textile heater, wires and sometimes metal sheets are used. Dorman® - Seat Heater Pad seen in **Figure 2a** and metal wires placed inside the car seat in **Figure 2b** are examples for textile-based car seat heaters.

Major applications of metal-based heating systems can be found in automotive, construction, sports and recreation sectors. Flexible, reliable and controllable heating systems have been manufactured using textiles. The common design approach is to insert metal wires onto woven fabrics [17]. In those systems, copper and nickel-chromium alloys are mainly used as heating elements. They are integrated into a layered textile system in order to be protected from damages when the seat is in use. Those systems include different controllable heating levels, from high to low which can be controlled by the user. Appropriate control to regulate the amount of heat and the duration of heating is very important in order to avoid excessive heat application to the user which could cause discomfort [18–20]. For this reason, on and off times are added to power control and management systems in today's automotive textile-based heating systems. In sports, recreation activities and in buildings, the similar design approach is taken into account. The main difference is only the size of application such that heating elements are placed on a much bigger scale, and so the power applied is also high [5]. Those applications do not require much flexibility, nor is weight an issue.

However, when the flexibility and drapability of a textile becomes important, polymer-based textile heating approaches take place. Indeed, how to create a comfortable wearable heating system is also a challenging issue and is a very important area of research.

With the introduction of polymer-based conductive yarns, polymer-based heating systems become great of interest for researchers and product developers. In a polymer-based heating system, when the direct current is applied, polymer-based conductive yarns carry the current and while carrying current they produce heat. In **Figure 3**, commercial flexible polymer-based products are seen. The presented commercial products by EXO2 uses FabRoc™ technology as it reduces automatically the use of power when the temperature increases. The power consumption and heat generated are easily controlled and make the product intrinsically safe. In this system, carbon-loaded silicone yarn which is made by the combination of silicone and carbon polymers, and then extruded in a patented process to produce FabRoc® yarn is used [5]. This system can be applied to the various range of product applications where the

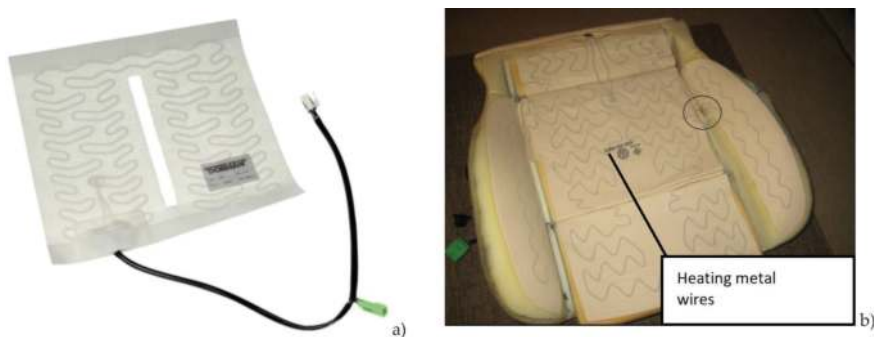

Figure 2. Textile-based car seat heaters (a) [15] (b) [16].



Figure 3. Flexible polymer-based (a) heated back support by EXO2 [21], (b) storm Walker jacket by EXO2 [22], and (c) DelphyneWomens 5 zone heated jacket [23].

flexibility is needed. Indeed, this system does not allow any yarn breakages or overheat as in use of wires and solid panels to accumulate.

The main applications of polymer-based textile heating systems are wearable heated fabric structures; heated vest, jacket, gloves, insoles, slippers, socks, therapeutic body warmers. In heated gloves (**Figure 4a**), extreme flexibility is required compared to jackets and vest since the arms and fingers exhibit excessive bending. For this reason, flexible conductive yarns, such as stainless steel yarns, silver plated polyamide yarns can be a good option as the heating element in those structures. The production technique can be knitting however the compatibility of the conductive yarn and its tolerance in terms of conductivity level for processing with knitting machine should be clearly investigated before starting production.

In a heated sock system (**Figure 4b**), polymer-based conductive yarns are knitted to the bottom of the foot through the heel and the toes to provide warmth.

In the slippers (**Figure 4c**), a heating system is generally made of woven structure composed of conductive fibers throughout the insole and placed between the foam and foot bed lining. In all systems, rechargeable lithium ion batteries are used as power supply to generate heat with a controller adjusting warmth level.

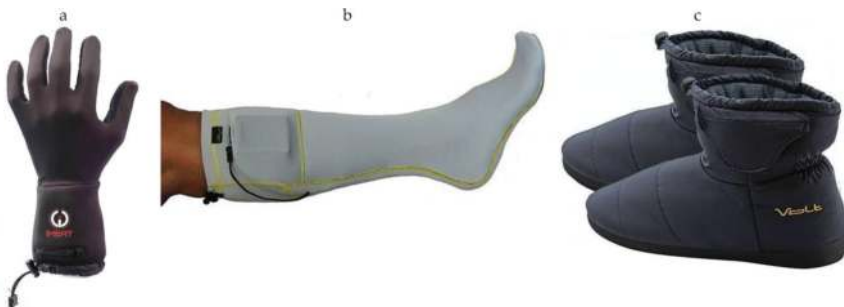

Figure 4. Flexible polymer-based heated glove, sock and slipper [24].



Figure 5. Flexible polymer-based heated insoles [24].

The heated insoles (**Figure 5**) provide a steady heat inside shoes and boots and they are operated by a wireless remote control. The insulated fabric structure does not allow the warmth to leak through the soles of footwear.

Flexible polymer-based therapeutic products provide heat to muscles, tendons and ligaments to increase blood circulation thereby relieving the sensation of pain [25] (**Figure 6**).

By positioning polymer-based heating structures behind the upholstery layers, protection against abrasion can be satisfied. Polymeric conductive yarns can be inserted on textiles structures using not only knitting techniques but also weaving, embroidery and stitching techniques. Then, the multilayered composite structures can be provided by coating, welding and lamination techniques according to specific usage area. For instance, in case waterproof property is needed, the textile structure (i.e. knitted, woven) including conductive yarns as heating element can be coated by different layers in order to provide waterproof property.

Wearable polymer-based heating systems are mostly advantageous because of their efficient heating and flexible structure for human body and they require less electrical power with



Figure 6. Flexible polymer-based therapeutic products [25].

small rechargeable batteries. They can be folded and compacted when they are not in use. They can be found in various range of products which can be worn in between layers of clothing and provide a controllable heating effect when required.

3. A wearable heating system with controllable e-textile-based thermal panel

This section describes the major considerations followed in the design and manufacture of the wearable heating vest. It starts with the design of e-textile-based thermal panel, followed by production process, electrical connection network and electronic control module. Finally, the assembly of all demanded components to reach the wearable heating vest is given in detail.

3.1. Design of e-textile-based thermal panel

During the design of the e-textile-based thermal panels, a number of factors are taken into consideration. First one among those was the selection of conductive yarn, examples of which are presented in **Figure 7**. In order to better investigate the effect of the resistance of the conductive yarn on resulting surface temperature, a total of seven stainless steel conductive yarns having resistance values of 4, 5, 9, 18, 30, 39 and 51 Ω/m were selected and used.

Secondly, the textile fabric was considered. For easier processability and their physical and mechanical superiority during processing and use, two PU-coated thermoplastic fabrics, namely Polyester and Polyamide fabrics, were used. Finally, three different welding tapes were selected for protection and waterproofness of the circuits made of conductive yarns, namely ST-604 with two PU layers, ST-306 with two PU and one Nylon layers, and ST-318 with two PU and one Polyester layers (see **Figure 8**). All three welding tapes selected are strong, resilient, and easy to work with. Since they do not contain plasticizers or volatile organic compounds, they are suitable for use in the production of e-textile transmission lines via a hot air welding technique. Welding was also previously shown to be an effective technique in the production of e-textile transmission lines [26].



Figure 7. Conductive yarns.



Figure 8. Welding tapes.

Depending on the fabric and welding tape to be used, processing temperatures and feeding rates were carefully selected in order to achieve proper adhesion of the tape while avoiding any harm on the fabric, the welding tape or the conductive yarn. The levels of processing temperatures (450–550°C) and feeding rates (1.5–12 ft./min) are carefully selected by preliminary trials.

Following the experimental trials, demanded amounts of conductive yarns are placed over the selected fabric, either polyamide or polyester, and covered by the selected welding tape using H&H AI-001 hot air welding machine, as presented in **Figure 9**. Thanks to the unique

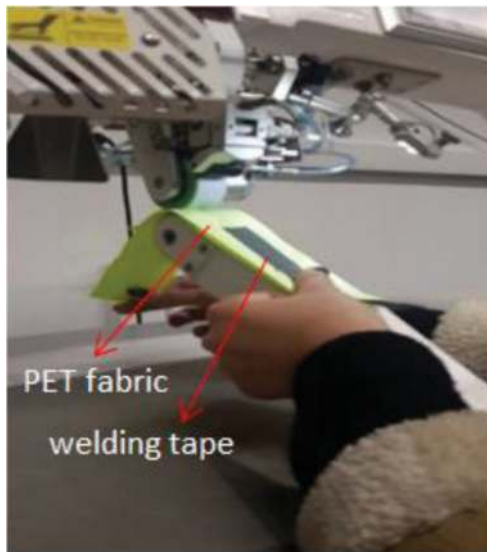

Figure 9. Manufacturing e-textile-based thermal panel using hot air welding machine.

excellent flexibility, lamination capability and soft hand properties of the welding tape, slippage of conductive yarns, distortion of overall fabric structure and thus formation of short circuits are avoided. Moreover, being manufactured from multilayered thermoplastic films, water leakages are prevented and edge fraying is eliminated by over bonded seams on conductive yarns.

Lithium batteries of three different potentials of 7.4, 9 and 12 V are used for application of potential difference to the samples. Details of the batteries are given in **Table 1**.

In order to avoid any interference during testing of the samples for their thermal performance via Fluke® Thermal Camera Ti200, a testing set up is prepared in a dark room compatible with AATCC TM 128 [27]. The dark room avoids any light or heat reflection from the walls, the floor or the ceiling, and does not have any other heat or light source other than those demanded during testing. An opaque 45° inclined background block is set into a dark testing cubicle. The thermal camera is locked to the tripod with its apparatus and they are placed together in front of the dark testing cubicle. At this point, the thermal camera was perpendicular enough to the inclined background block, and the distance between the thermal camera and the specimens is adjusted to 34–38 cm so that the errors were negligible, as instructed by the manufacturer of the thermal camera. Demanded amount of potential difference, 7.4, 9 or 12 V, is applied using the related battery, and thus a current flowing through the conductive yarns is created. SmartView® Software is used to analyze the specimens after they are tested. Emissivity value of opaque background block is estimated to have a value of 0.95. **Figure 10** shows the experiment set up to test electrical heating in which the e-textile structure is connected to a battery (power supply) by the electrical crocodiles.

An example of the thermal image of the e-textile sample together with sample's original image is given in **Figure 11**.

For the selection of better e-textile-based thermal panel, some criteria were applied. When the performance of the final product is considered, the leading factors to be taken into account were selected as a deviation of tested surface temperature from optimal surface temperature, battery life and battery weight. An optimal surface temperature of 60°C is considered, and any sample having tested surface temperature below 55°C or over 65°C are excluded. Considering battery life and battery weight; 12 V applied Polyester – ST306–550°C – 6 ft./min with 5 Ω resistance seems to be the optimal sample. It has 17 h of battery life and can heat the garment up to 57–58°C. The weight of the battery that is used for this sample to supply 12 V potential difference was 295 g.

Potential (V)	Type	Electric power (Ah)	Weight (g)	Price (USD)
7.4	Lithium	2.5	120	14.5
9	Lithium	10	254	16.5
12	Lithium	6.8	295	15.0

Table 1. Characteristics of lithium batteries.



Figure 10. Testing set up to measure surface temperature.

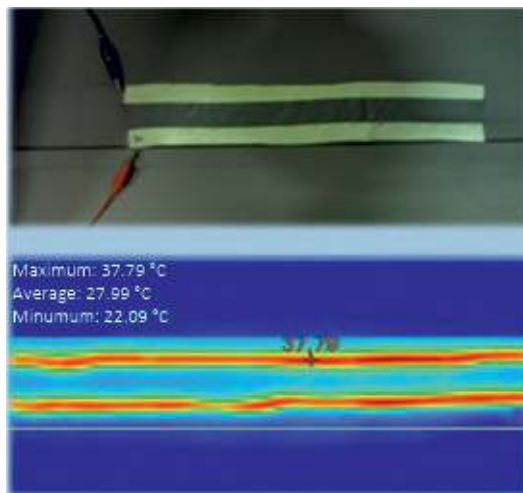

Figure 11. Original e-textile sample and its thermal image acquired by the thermal camera.

3.2. Production process

For manufacturing e-textile-based thermal panel to be placed inside the wearable heating vest, stainless steel yarn of $5 \Omega/\text{m}$ resistance is placed over approximately $35 \times 45 \text{ cm}$ of PVA interlining. PVA interlining is easily dissolved when in contact with water at over 50°C , and was selected on purpose in order to observe the waterproof property of the thermal panel. The placement of the conductive yarn is as given in **Figure 12**.



Figure 12. Placement of conductive yarn over interlining.



Figure 13. E-textile-based thermal heating panel to be placed inside the heating vest.

Maximum care is taken during placement of the conductive yarn in order to avoid the formation of the short circuit. Transmission lines made of conductive yarns are then covered with ST306 welding tape as shown in **Figure 9**. For reaching 550°C of temperature during adhesion of ST306 welding tapes over the conductive yarns, hot press is used. Hence, the structure including conductive yarns covered by welding tapes became flexible, soft and waterproof. Having high bending strength aside with flexibility, the distortion and slippage of the conductive yarns are prevented. Thus, over bonded e-textile structure eliminates short circuit formation and hot/cold spot formation when folded. Finally, the interlining comprising conductive yarns is placed between two folds of 40 × 50 cm of PU-coated polyester fabrics and stitched on all four sides to reach the final e-textile-based thermal heating panel. Moreover, a pocket for inserting the electronic control module is attached to the left bottom side of the panel, at the bottom of which two snap fasteners are placed on which alternating ends of the conductive yarn are soldered. A total of eight brit buttons are stitched all around the panel for easier attachment and displacement of the panel when desired. The final e-textile-based thermal panel to be placed inside the vest is presented in **Figure 13**.

3.3. Electrical network and electronic control module

For supplying the demanded potential difference an electronic control module is designed and manufactured. Three 3.7 V batteries are connected in series, and used as power supplies. The technical drawing for control module circuit is as presented in **Figure 14**. The circuit brings protection against short circuits and electrical overload. To prevent electrical overloads, circuit breakers are used to stop the flow of current to the overloaded transmission

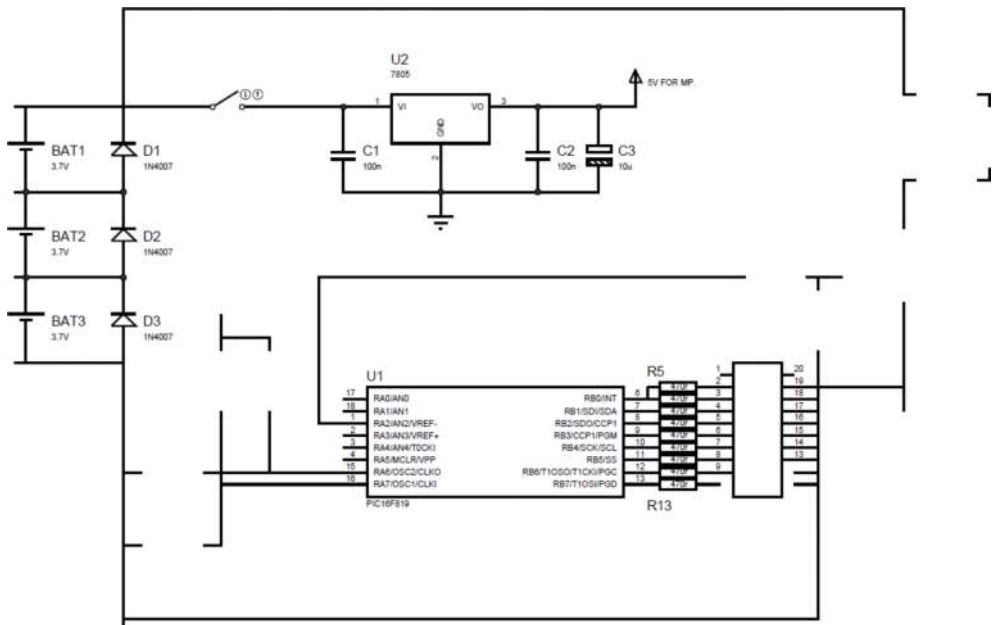

Figure 14. Technical drawing for control module.

lines. Hence, the control module with its circuit provides electrical safety. Moreover, thanks to its special design, the circuit is able to feed the system with constant energy output by automatically leveling the energy input from the batteries during use.



Figure 15. Electronic control module.



Figure 16. Insertion of electronic control module inside the pocket on the panel.

The manufactured circuit card is placed in an HH-0055 model $76 \times 112 \times 26$ mm standard box. The control module, as shown in **Figure 15**, has 10 heating levels equipped with 10 LED displays which show the total energy output adjusted by the user at the desired comfort level. It has a total weight of less than 200 g.

Through the two snap fasteners at the bottom of the box, the control module is easily fastened after being inserted inside the pocket at the bottom left of the e-textile-based heating panel as shown in **Figure 16**. It has an on/off switch which is easily reachable by the user of the heated vest without being taken out of the pocket in which the module is inserted.

When connected to DC via its charger as shown in **Figure 17**, the control module can be fully recharged in 11 h, and keeps on supplying the heated vest with demanded energy at 10th level (up to 22 W) for as long as 4.5 h when used outdoors at an ambient temperature

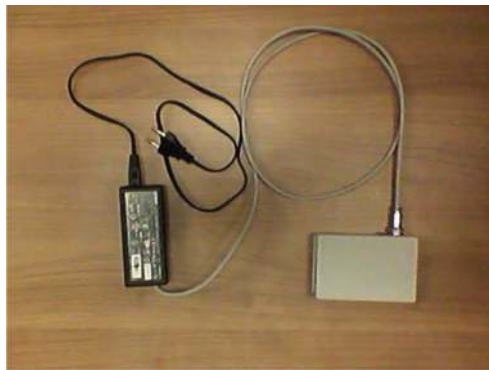

Figure 17. Connection of electronic control module and its charger.



Figure 18. Wearable heating vest (a) view from inside and (b) view from outside.

of 10°C. Thanks to the special design of the pocket in which it is inserted and fastened, the control module can be recharged without removal from the pocket.

3.4. A wearable heating vest

The integration of e-textile-based thermal heating panel to the vest is presented in **Figure 18a**. Eight buttons are stitched inside the vest on the corresponding locations where they will be fastened to the brits on the panel. Thanks to the eight brit buttons stitched all around the panel, the panel can be attached and displaced easily, and does not slip or cause discomfort of the wearer while putting on. Because of the proper selection of the place of the inner pocket in which the electronic control module is inserted, there is no distortion on the heated vest as shown in **Figure 18b**.

4. Real-time monitoring of the heating vest performance

For observation and monitoring of the heating performance of the heated vest in real-time, the vest was worn by a volunteer, and thermal camera images from the front and back of the torso were taken after wearing for 30 s, and from the back torso when the heating vest is on for 10 min and immediately after putting off at an ambient temperature of 21°C. As the ambient temperature was 21°C, the heating vest was set for a heating level of 5. As presented in **Figures 19** and **20**, the front temperature on the surface of the vest reached 23.5°C, and back temperature on the surface of the vest reached 25.5°C just 30 s after wearing the heating vest, respectively. It is apparent that the heating vest quickly starts heating up, and the heat is evenly distributed even after 30 s.

As presented in **Figures 21** and **22**, the back temperature on the surface of the vest reached 30.2°C, 10 min after wearing, and the surface temperature on the top clothing immediately after putting off was observed as high as 38.4°C, respectively.

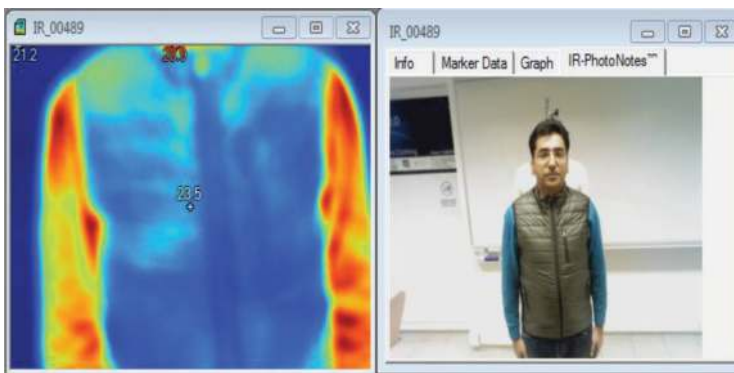

Figure 19. Thermal and actual images on first 30 s after wearing the heating vest (Front surface temperature on the vest: 23.5°C, ambient temperature: 21°C).

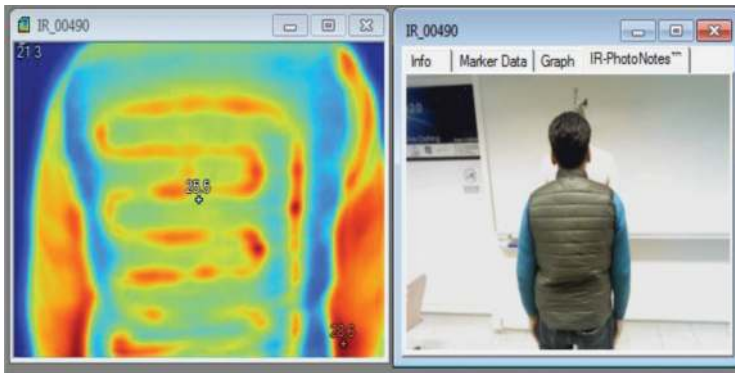

Figure 20. Thermal and actual images on first 30 s after wearing the heating vest (Back surface temperature on the vest: 25.5°C, ambient temperature: 21°C).

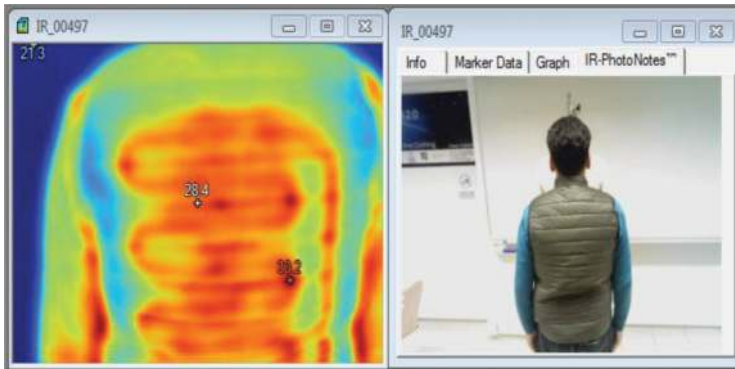

Figure 21. 10 min after wearing the heating vest (Back surface temperature on the vest: 30.2°C, ambient temperature: 21°C).

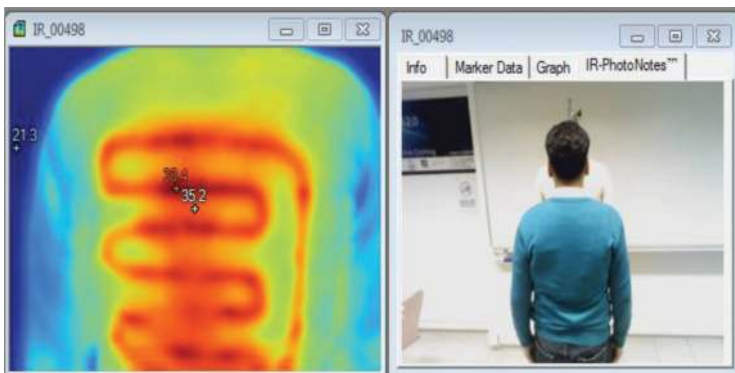

Figure 22. 10 min after wearing the heating vest (Back surface temperature on the top clothing of wearer: 38.4°C, ambient temperature: 21°C).

5. Future trends

The textile-based heating systems are one of the influential developments in wearable electronic textiles. Heating with textile structure requires conservation of battery life with respect to power output. To compromise wearability between cost, bulk, heat output and the lifespan of the battery is not an easy task. Indeed, the current battery technology restricts the scale of electrical heating that can conveniently be applied. In the future, the development of flexible fuel cells or supercapacitor technology may soon become a realistic alternative to rechargeable batteries. Moreover, another promising effector technology lies in the washability concept of those wearable textile-based heating systems. In addition, attractive efforts would be on solutions for interconnectivity between the power supply and the polymer-based heating elements.

Acknowledgements

This research work was supported by the Ministry of Science, Industry and Technology of TURKEY, with the project titled "Design of e-textile-based thermal heating panels via welding technology, Project No.0034.TGSD.2015-2". The researchers would like to thank CETEKS Elektronik Tekstil San. Tic. Ltd.Şti for final prototype development.

Author details

Senem Kurşun Bahadır* and Umut Kivanc Sahin

*Address all correspondence to: kursuns@itu.edu.tr

Faculty of Textile Technologies and Design, Department of Textile Engineering, Istanbul Technical University, Istanbul, Turkey

References

- [1] Malmivaara M. In: McCann J, Bryson D, editors. *The Emergence of Wearable Computing, Smart Clothes and Wearable Technology*. Cambridge: Woodhead Publishing; 2009
- [2] Bahadır SK, Sahin UK, Kiraz A. Modeling of surface temperature distributions on powered e-textile structures using an artificial neural network. *Textile Research Journal*. 2017. DOI: 10.1177/0040517517743689
- [3] Bahadır SK. The effect of textile pretreatment processes on signal transferring capability of textile transmission lines. *Fibres & Textiles in Eastern Europe*. 2015;23(2(110)):55-62
- [4] Bahadır SK, Jevnik S, Fakin D, Sahin UK. Color and electrical resistance evaluation of cotton fabrics composed of stainless steel yarns treated with direct and reactive dyes. *Textile Research Journal*. 2016;86(13):1356-1371

- [5] Mbise E, Dias T, Hurley W. Design and manufacture of heated textiles. In: Dias T, editor. *Electronic Textiles: Smart Fabrics and Wearable Technology*. Cambridge: Woodhead Publishing; 2015
- [6] Swallow S, Thompson AP. In: Mattila HR, editor. *Intelligent Textiles and Clothing*. Cambridge: Woodhead Publishing; 2006
- [7] Xu D-H, Cheng J-X, Zhou X-H. A model of heat and moisture transfer through parallel-pore textiles. *Journal of Fiber Bioengineering and Informatics*. 2011;**3**:250-255
- [8] Hsieh Y-L. Liquid transport in fabric structures. *Textile Research Journal*. 1995;**65**:299-307
- [9] Sousa LHCD, Monteiro AS, Perri VR, Motta Lima OC, Pereira NC, Mendes ES. Generalization of the drying curves in convective and conductive/convective textilefabric drying. In: 14th International Drying Symposium, São Paulo; 2004. pp. 710-717
- [10] Sampath M, Aruputharaj A, Senthilkumar M, Nalankilli G. Analysis of thermal comfort characteristics of moisture management finished knitted fabrics made from different yarns. *Journal of Industrial Textiles*. 2012;**42**:19-33
- [11] Au KF. *Advances in Knitting Technology*. Cambridge: Woodhead Publishing Series in Textiles; 2011
- [12] Kar F, Fan J, Yu W, Wan X. Effects of thermal and moisture transport properties of T-shirts on wearer's comfort sensations. *Fibers and Polymers*. 2007;**8**:537-542
- [13] Kissa E. Wetting and wicking. *Textile Research Journal*. 1996;**66**:660-668
- [14] Altmann D, Haupt E, Knuppel M. Heated seat. Google Patents; 1990
- [15] Available from: <https://www.carid.com/dorman/seat-heater-pad.html?make=Chevy&model=Avalanche> [Accessed on February 3 2018]
- [16] Available from: <http://forums.tdiclub.com/showthread.php?t=423547> [Accessed on February 3 2018]
- [17] Weiss M. Flat heating element. Google Patents; 2013
- [18] Buie D, Buie J. Temperature controlled seat cover assembly. Google Patents; 1997
- [19] Fangueiro R, Filgueiras A, Soutinho F, Meidi X. Wicking behavior and drying capability of functional knitted fabrics. *Textile Research Journal*. 2010;**80**:1522-1530
- [20] Sweeney M, Branson D. Sensorial comfort. *Textile Research Journal*. 1990;**60**:371-377
- [21] Available from: <http://www.exo2theheatinside.com/markets/medical-therapeutic-rehab/heatwave-back-support.html> [Accessed on February 3 2018]
- [22] Available from: <http://www.exo2theheatinside.com/markets/hunting-fishing-outdoors/stormwalker-jacket.html> [Accessed on February 3 2018]
- [23] Available from: <https://dragonheatwear.com/collections/womens/products/delphyne-womens-heated-puffer-jacket> [Accessed on February 3 2018]

- [24] Available from: <http://www.staywarmed.com> [Accessed on February 3 2018]
- [25] Available from: <https://www.thewarmingstore.com/heating-pads.html> [Accessed on February 3 2018]
- [26] Bahadir SK, Kalaoglu F, Jevsnik S. The use of hot air welding technologies for manufacturing E-textile transmission lines. *Fibers and Polymers*. 2015;**16**(6):1384-1394
- [27] AATCC TM128-2017. Wrinkle Recovery of Fabrics: Appearance Method. Research Triangle Park, NC, USA: Association of Textile, Apparel & Materials Professionals Technical Manual